

Planning aid

Australia collection
Kitchen appliances
2026/2027

Note on content

Please note

This planning aid applies to the specified model numbers only. Older planning aids for earlier generation models may be requested in electronic form from our Customer Services.

This planning aid is not to be used as installation instructions! The regulations and instructions binding for the appliance installation are to be obtained from the installation instructions packed with the appliances. The installation instructions can also be downloaded from the internet from www.vzug.com/b2b.

Changes

Text, diagrams and data correspond to the technical standard of the appliances at the time this planning aid went to press. The right to make technical modifications for the purpose of the further development of the appliances is reserved. The German, English, French and Italian versions are binding. V-ZUG accepts no liability for translations in other languages.

Symbols used



Denotes important safety precautions.

Failure to observe said precautions can result in injury or in damage to the appliance or fittings!

- ▶ Indicates an instruction.
- Indicates a list.



Information and precautions that should be observed.



Extraction



Recirculation

Supplementary documents

In this planning aid, occasional reference is made to supplementary documents. These documents can be requested from the Head Office in Zug by sending an e-mail to service-support@vzug.com.

Useful links

- www.vzug.com
- www.vzug.com/b2b/



Contents

1 Overview of connections, ranges and dimensions	5
1.1 General operating conditions	5
1.2 Using residual current devices in house wiring system / fault current	5
1.3 Validity	6
1.4 Positions of electrical connections	9
1.5 Built-in EURO	10
1.6 Front dimensions of Excellence appliances	11
2 Steamers	13
2.1 General notes	13
2.2 Electrical connection data	13
2.3 Excellence Line 90 cm	14
2.4 Excellence Line 60 cm	14
3 Ovens	18
3.1 General notes	18
3.2 Electrical connection data	18
3.3 Excellence Line 60 cm	18
3.4 Advanced Line 60 cm	19
4 Vacuum drawers, warming drawers & system drawers	20
4.1 General notes	20
4.2 Electrical connection data	20
4.3 Vacuum drawers	21
4.4 Warming drawers	24
4.5 System drawers	26
5 Microwaves	27
5.1 General notes	27
5.2 Electrical connection data	27
5.3 Microwaves with niche width 60 cm	27
6 Automatic built-in coffee machines	28
6.1 General notes	28
6.2 Electrical connection data	28
6.3 CoffeeCenter V6000 45 (25005)	28
7 Combination possibilities	29
7.1 Oven & steam cooker	29
7.2 Oven & microwave oven	30
7.3 Oven & automatic built-in coffee machine	31
8 CookTop glass ceramic hobs	32
8.1 General notes	32
8.2 OptiGlass coating	32
8.3 Electrical connection data	32
8.4 Ventilation	33
8.5 Surface-mounted installation with «DualDesign»	34
8.6 Flush installation with «DualDesign»	40
8.7 Installation without protective plate	46
8.8 Installation with protective plate	48
9 Gas hobs	51
9.1 Electrical connection data	51
9.2 Gas connection	52
9.3 Ventilation	53
9.4 Setting up appliance to use local gas type	53
9.5 Surface-mounted installation with «DualDesign»	54
9.6 Flush installation with «DualDesign»	57
10 Combined hob installation	60
10.1 Surface-mounted combination	60
10.2 Examples of surface-mounted combinations	61
10.3 Flush combination	62
10.4 Examples of flush combinations	63
11 CombiCookTop induction hob with hood	64
11.1 Electrical connection data	64
11.2 Dimensions	64



11.3	Scope of delivery	66
11.4	Ventilation of the hob	67
11.5	Surface-mounted installation	68
11.6	Flush installation	69
11.7	Installation overview for base	70
11.8	Flat channel systems made of plastic (PRIME) for the CombiCookTop I604	73
11.9	Flat channel systems made of plastic (PRIME) for the CombiCookTop I804	74
11.10	Flat channel systems made of metal (RF1) for the CombiCookTop I804	75
11.11	Recirculation mode	76
11.12	Extraction mode	76
12	Range hoods	78
12.1	General notes	78
12.2	Special hoods	79
12.3	Built-in range hoods	93
13	Dishwashers	95
13.1	General notes	95
13.2	Electrical connection data / Plumbing-in data	96
13.3	Installation overview	98
13.4	Drilling plans for decor panel 60 cm	99
13.5	Dishwashers with niche width 60 cm	100
14	Dishwashers with heat pump	106
14.1	General notes	106
14.2	Electrical connection data / Plumbing-in data	107
14.3	Installation overview	108
14.4	Drilling plans for decor panel 60 cm	109
14.5	Dishwashers with niche width 60 cm	110
15	Refrigerating and freezing appliances	112
15.1	General notes	112
15.2	Electrical connection data	112
15.3	Ambient conditions	113
15.4	Niche ventilation	114
15.5	Refrigerators	115
15.6	Wincoolers	120
15.7	Freezers	123
16	Accessories	125
16.1	Ovens / steamers / microwave ovens / coffee machines / vacuum drawers / warming drawers / system drawers	125
16.2	Hobs and gas hobs	128
16.3	Range hoods	130
16.4	Dishwashers	144
16.5	Refrigerating and freezing appliances	145
17	V-ZUG-Home	147
17.1	Internet access	147
17.2	Scope of delivery	147
17.3	Connecting to the home network	147
	Index	148



1 Overview of connections, ranges and dimensions



Electrical connections must be carried out by qualified personnel in accordance with the guidelines and standards for low-voltage installations and the specifications of the local electricity supply companies.

A plug-in appliance may only be connected to a socket outlet with earthing contact, installed according to specifications. An all-pole mains isolating device with 3 mm contact opening should be provided in the house wiring system. Switches, plug and socket devices, circuit breakers and fusible cut-outs which are accessible after installation and which have all-poles switching are permissible as isolating devices. Effective earthing and separately installed neutral and earth conductors ensure safe and fault-free operation. After installation, live parts and cables with basic insulation must not be accessible. Check old installations.

1.1 General operating conditions



Detailed information on the electrical connection data can be found at the beginning of each section.

Value	Nominal value	Minimum	Maximum
Voltage	220-240 V	198 V	253 V
Voltage	380-415 V	342 V	440 V
Frequency	50 Hz sinusoidal	49 Hz sinusoidal	51 Hz sinusoidal

- Short duration frequency variation in the mains: $\pm 5\%$
- Long duration frequency stability in the mains (for synchronous clocks): ± 10 ppm
- The appliances are designed for use up to an altitude of 2000 m above sea level.

1.2 Using residual current devices in house wiring system / fault current

High fault currents are inherently present in ovens and hobs. The values can be affected by various factors and vary widely. Fault currents of up to approximately 10 mA per appliance are permissible in accordance with the norm. The values are measured in the warm operating state.

If residual current devices (RCDs) are used in the house wiring system, we recommend that the above-mentioned appliances have their own RCD protection, separate from the power supply for the rest of the system. 30 mA or higher should be selected as the tripping current for the residual current device.



1.3 Validity

The model number corresponds to the first alphanumeric of the serial number SN (or FN) on the identification plate.

Model designation	Model number	Type
Steamers		
Steamer V4000 45	23026	S4T-23026
CombiSteamer V4000 45	23031	CS4T-23031
CombiSteamer V6000 45	23032	CS6T-23032
CombiSteamer V6000 45F	23033	CS6T-23033
CombiSteamer V6000 45L Grand	23034	CS6T-23034
CombairSteamer V2000 60	23036	CS2T-23036
CombairSteamer V6000 60	23038	CS6T-23038
CombiSteamer V6000 45M PowerSteam	23041	CSM6T-23041
CombiSteamer V6000 45	23043	CS6T-23043
CombiSteamer V6000 45F	23045	CS6T-23045
CombiSteamer V6000 45L Grand	23046	CS6T-23046
CombiSteamer V6000 45M PowerSteam	23047	CSM6T-23047
CombairSteamer V6000 60	23049	CS6T-23049
Ovens		
Combair V2000 60	21043	C2T-21043
Combair V4000 60	21045	C4T-21045
Combair V6000 60	21047	C6T-21047
Combair V2000 45	21048	C2T-21048
Combair V4000 45	21049	C4T-21049
Combair V6000 45	21050	C6T-21050
Combair V4000 60P	21055	C4T-21055
Combair V6000 60P	21057	C6T-21057
Combair V4000 45P	21058	C4T-21058
Combair V6000 45P	21059	C6T-21059
Combair V6000 45	21067	C6T-21067
Combair V6000 60	21068	C6T-21068
Combair V6000 45P	21070	C6T-21070
Combair V6000 60P	21073	C6T-21073
Combair V600 60	21128	C6H-21128
Vacuum drawers		
VacuDrawer V6000 14	36004	DV6T-36004
VacuDrawer V6000 14	36005	DV6T-36005
Warming drawers		
WarmingDrawer V4000 14	34026	DW4T-34026
WarmingDrawer V4000 14	34027	DW4T-34027
WarmingDrawer V4000 22	34029	DW4T-34029
WarmingDrawer V4000 28	34030	DW4T-34030
WarmingDrawer V4000 31	34031	DW4T-34031



Model designation	Model number	Type
System drawers		
Drawer V2000 14	35005	DS2T-35005
Microwaves		
CombiMiwell V4000 45	24025	CM4T-24025
Automatic built-in coffee machines		
CoffeeCenter V6000 45	25005	COC6T-25005
Hobs		
CookTop V6000 I905	31114	CTI6T95MMSOLD
CookTop V4000 I604	31115	CTI4T64MMSOLD
CookTop V4000 I704	31116	CTI4T74MMSOLD
CookTop V6000 I705 FullFlex	31132	CTI6T-31132
CookTop V6000 I906 FullFlex	31134	CTI6T-31134
CookTop Teppan Yaki I40	31140	CTI2T-31140
CookTop V4000 I904	31142	CTI4T-31142
CookTop V4000 I402	31144	CTI4T-31144
CookTop V4000 I604	31157	CTI4T-31157
CookTop V4000 I804	31158	CTI4T-31158
CookTop V2000 I604	31179	CTI2T-31179
CookTop V2000 I804	31182	CTI2T-31182
Gas hobs		
GAS411 multi-slider	31063	GAS411GSBZ
GAS421 multi-slider	31064	GAS421GSBZ
GAS641 multi-slider	31071	GAS641GSBZ
GAS951 multi-slider	31072	GAS951GSBZ
GAS731 dial controls	31075	GAS731GKBZ
Induction hobs with integrated hood		
CombiCookTop V2000 I804	31095	CCT2T-31095
CombiCookTop V4000 I804	31096	CCT4T-31096
CombiCookTop V2000 I604	31175	CCT2T-31175
CombiCookTop V2000 I604	31176	CCT2T-31176
Range hoods: Special hoods		
DSTS downdraft hood	64015	DSTS9-64015
DSMS downdraft hood	64005	DSMS
Built-in range hoods		
AiroClearCabinet V4000 H60	64009	AE4T-64009
AiroClearCabinet V4000 H90	64010	AE4T-64010
AiroClearCabinet V4000 H90	64011	AE4T-64011
Dishwashers		
AdoraDish V2000	41162	AS2T-41162
AdoraDish V6000	41147, 41171, 41173	AS6T-41147, AS6T-41171, AS6T-41173



Model designation	Model number	Type
Refrigerators		
CombiCooler V6000 178NI	51149	CCO6T-51149
CombiCooler V4000 178NI	51151	CCO4T-51151
Cooler V4000 178K (-T)	51140	CO4T-51140
CombiCooler V6000 75 Supreme	51115	CCO6T-51115
Cooler V6000 75 Supreme	51116	CO6T-51116
CombiCooler V6000 90 Supreme	51133	CCO6T-51133
Cooler V6000 90 Supreme	51134	CO6T-51134
Winecoolers		
WineCooler V4000 90	51102	WC4T-51102
WineCooler V4000 45	51113	WC4T-51113
WineCooler V6000 60 Supreme	51154	WC6T-51154
Freezers		
Freezer V4000 178N (-T)	53009	FR4T-53009
Freezer V6000 60 Supreme	53006	FR6T-53006

1.4 Positions of electrical connections

For EURO kitchens, allowance from the floor can vary. In this case, the electrical connection should be calculated using the dimension from the bottom edge of the appliance.

Oven above an oven

With this combination, an electrical connection should be provided for each appliance. Depending on the installation height and the type of combination, the connections may be located at different heights.

Wall hoods with telescopic casing

The electrical connection must pass between the exhaust air piping and the lagging sheets. The measurements given in the table ensure that this condition is met.

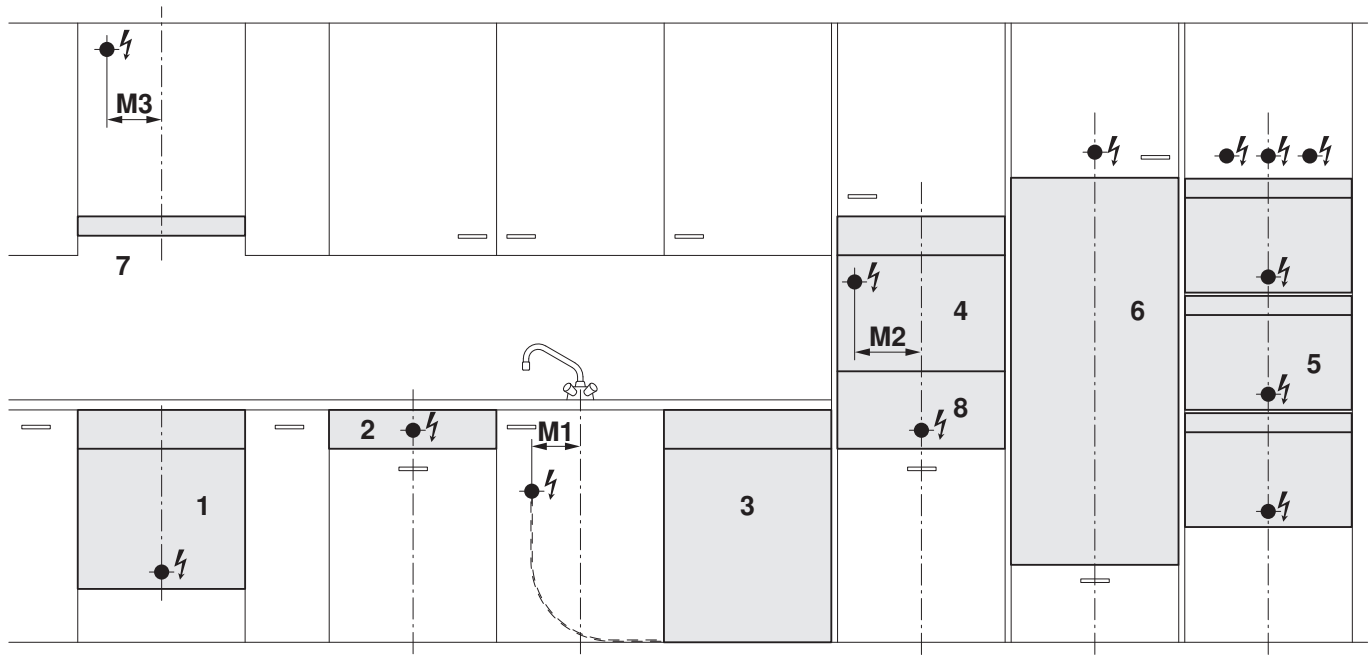

- 1 Oven/Steamer in base unit
- 2 Autarchic hob
- 3 Dishwasher/Refrigerator in base unit
- 4 Automatic built-in coffee machine / Microwave oven
- 5 Oven / Steamer / Microwave oven, also in combination
- 6 Refrigerator, WineCooler in tall unit. **Note:** Position of socket not applicable to models from the V6000 Supreme Line.
- 7 Range hood
- 8 Drawers (warming drawer / vacuum drawer / system drawer)

- M1 Distance from centre to dishwasher/refrigerator connection in base unit
- M2 Distance from centre to connection for automatic built-in coffee machine / microwave oven (option)
- M3 Distance from centre to range hood connection



Provide additional clearance for electrical connections if the installation niche has only the minimum depth.



1.5 Built-in EURO

No.	Designation	Connection from appliance support	Connection in niche	Type of connection
1	Oven, steamer (height 600 mm)	max. 30 mm (for plinth height 100 mm)	Centre	I
2	Autarchic hob	–	Centre	I
3	Dishwasher	–	M1 = 160 mm	U
	Refrigerator in base unit	–	M1 = 160 mm	U
4	Oven, steamer (height 600 mm)	max. 30 mm	Centre	I
	Oven, steamer (height 380 mm / 450 mm)	max. 30 mm	Centre	I
	Microwave oven (height 380 mm)	max. 300 mm	Centre, M2 = 225 mm (option)	I, U
	Microwave oven (height 450 mm)	max. 400 mm	Centre, M2 = 225 mm (option)	I
	Automatic built-in coffee machine	max. 300 mm	M2 = 225 mm	I, U
5	Double combination (height 600 mm) Triple combination variants	max. 30 mm	Centre	I, U
6	Refrigerator, winecooler in tall unit up to and including 12/6, EURO 1530 mm	–	Centre	U
	Refrigerator in tall unit from 13/6, EURO 1540 mm	–	Centre	U
8	Warming drawer, vacuum drawer	–	Centre	U

I See separate installation instructions

M1 Distance from centre to dishwasher/refrigerator connection in base unit

M2 Distance from centre to connection for automatic built-in coffee machine / microwave oven (option)

U Flush power socket 220–240 V

1.6 Front dimensions of Excellence appliances



Manufacturing tolerance: ± 1 mm

Oven/Steamer in tall unit

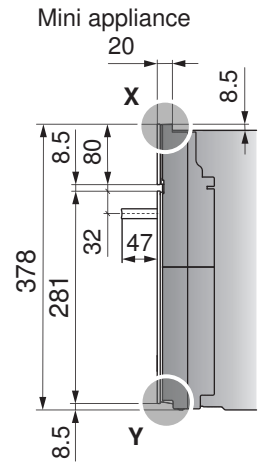
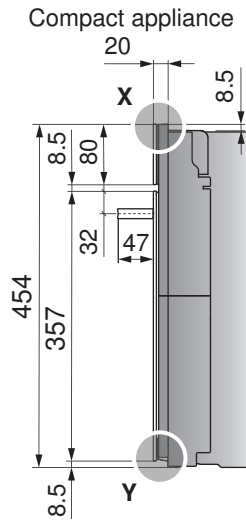
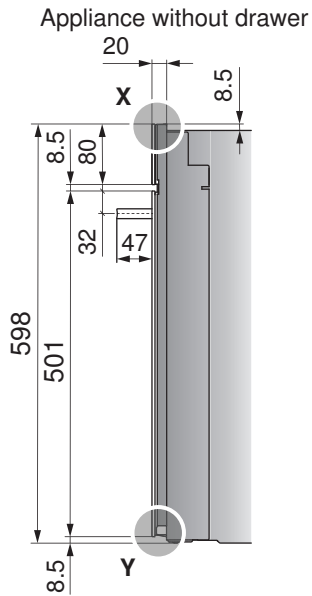

Detail X

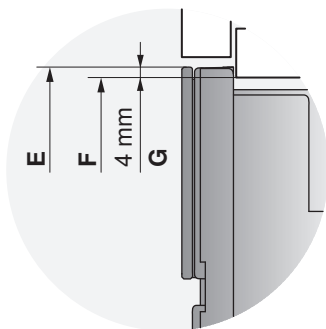

Detail Y

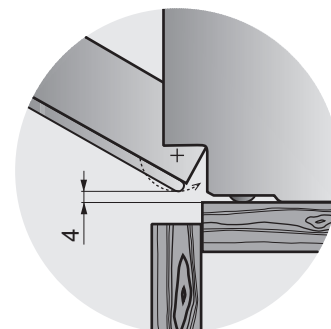

- E** Appliance height
- F** Niche height
- G** Overlap

Vacuum, warming and system drawer

Appliance height H	Door glass height H2
310	301.5
281	272.5
218	209.5
160	151.5
142	133.5
74	65.5

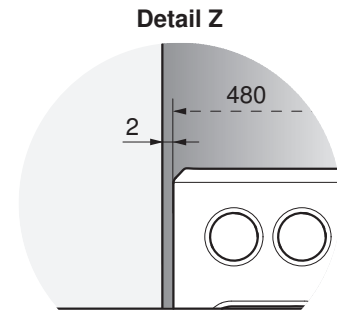
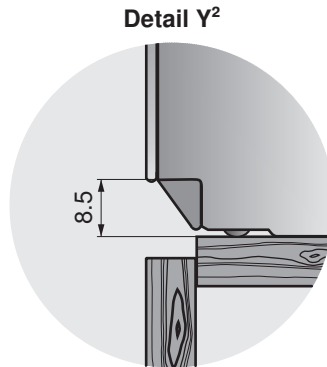
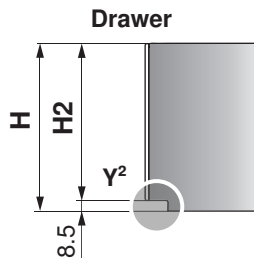

2 Steamers

Only use if water hardness $>3^{\circ}$ French hardness ($>1.7^{\circ}$ German hardness).

2.1 General notes



Efficient repairs can only be guaranteed if it is possible to uninstall the whole appliance at any time without causing any damage.

The niche and gap dimensions given below must be observed to ensure proper ventilation.

2.2 Electrical connection data



General information on the electrical connections and an overview of the positions can be found in section Overview of connections, ranges and dimensions (see page 5).

Appliance	Model number	Mains connection	Fuse	Rated load	Mains cable
CombairSteamer V2000 60	23036	220–240 V~ 50 Hz	16 A	3700 W	min. 1.8 m, without plug
CombairSteamer V6000 60	23038, 23049				
CombiSteamer V4000 45	23031				
CombiSteamer V6000 45	23032, 23033, 23043, 23045				
CombiSteamer V6000 45L Grand	23034, 23046				
Steamer V4000 45	23026				
CombiSteamer V6000 45M PowerSteam**	23041, 23047	220–240 V~ 50 Hz	16 A	3700 W	min. 1.8 m, without plug
CombiSteamer V6000 45M PowerSteam			25 A***	5100 W	
		380–415 V 2N~ 50 Hz	16 A		

** The CombiSteamer V6000 45M PowerSteam can also be operated with a single-phase connection (230 V~/16 A). For performance reasons (less power means longer cooking times), it should, where possible, be connected with a two-phase connection.

*** This appliance complies with the requirements of IEC 61000-3-12. If the appliance is to be fitted with a 25 amp fuse, this must be activated in the appliance settings.

2.3 Excellence Line 90 cm

CombiSteamer

CombiSteamer V6000 45L Grand, niche height 450

Valid for the following models: 23034, 23046

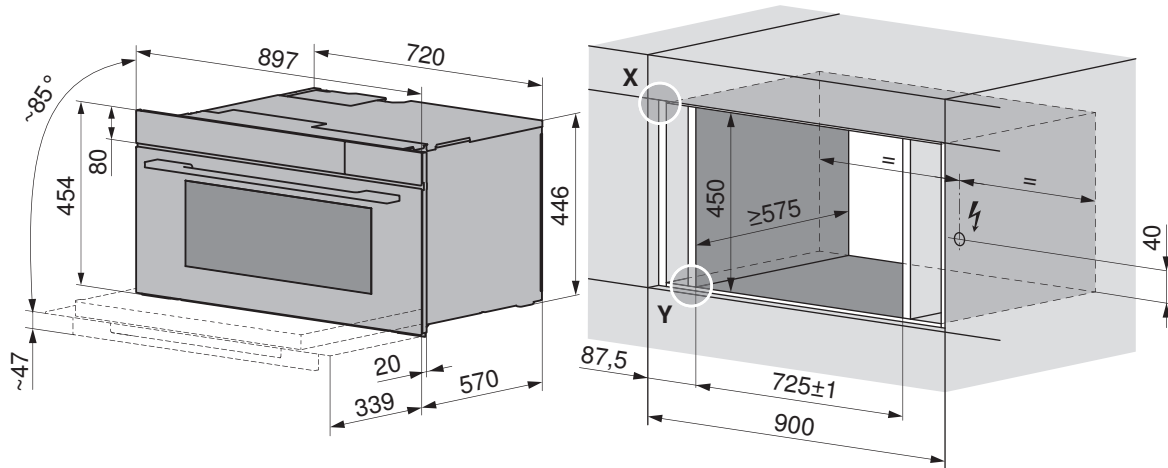

Front dimensions of the appliances: Detail X/Y (see page 11)

2.4 Excellence Line 60 cm

CombairSteamer

CombairSteamer V2000/V6000 60, niche height 600

Valid for the following models: 23036, 23038, 23049

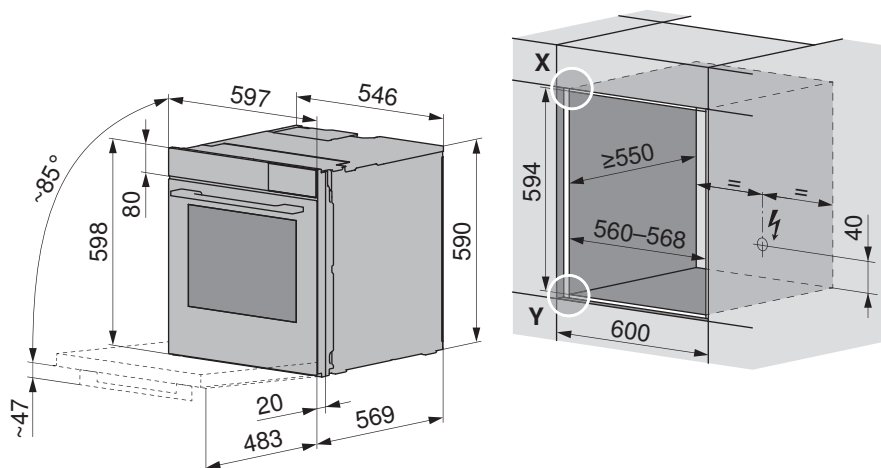

Front dimensions of the appliances: Detail X/Y (see page 11)

CombiSteamer/Steamer

CombiSteamer V6000 45M PowerSteam, CombiSteamer V4000/V6000 45 and Steamer V4000 45, niche height 450

Valid for the following models: 23026, 23031, 23032, 23041, 23043, 23047

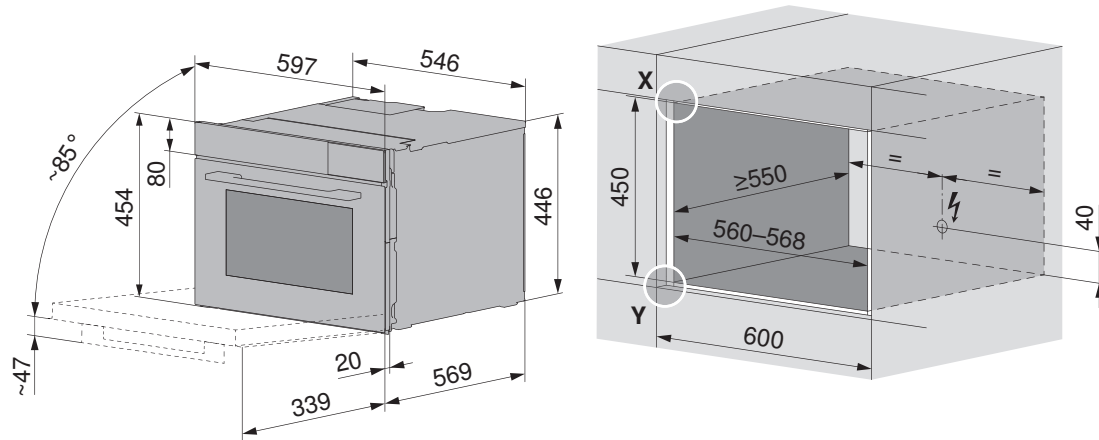

Front dimensions of the appliances: Detail X/Y

CombiSteamer with fixed water connection

CombiSteamer V6000 45F, niche height 450

Valid for the following models: 23033, 23045

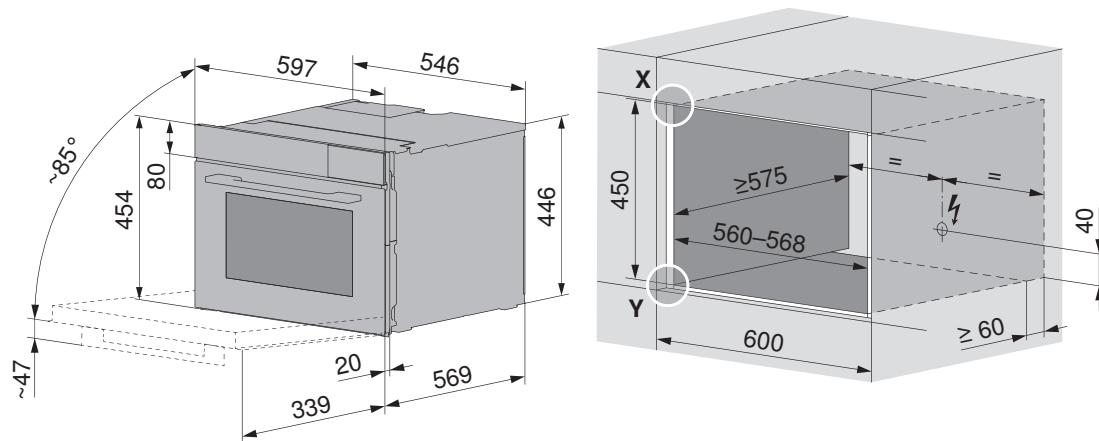

Front dimensions of the appliances: Detail X/Y (see page 11)

Below second appliance

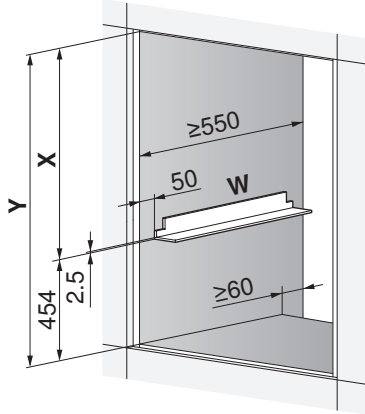

Above second appliance

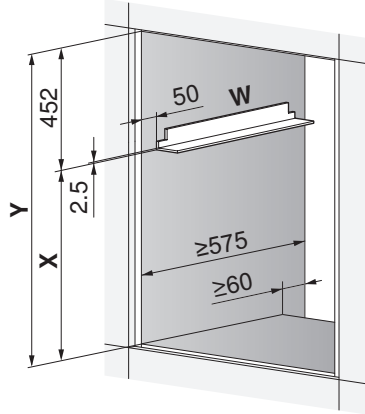

Above warming drawer

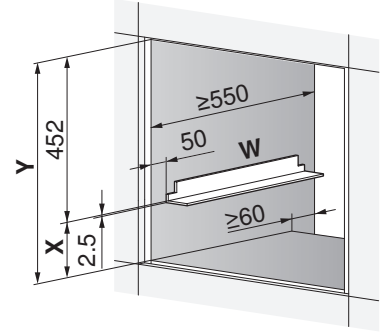

X = Height of second appliance

Y = Niche height

W = Angle set K50572



For an installation depth of under 575 mm, it is recommended that the appliance be installed below other appliances for space reasons.

If installing with a second appliance in the same niche, use the angle set W (K50572).

Installation

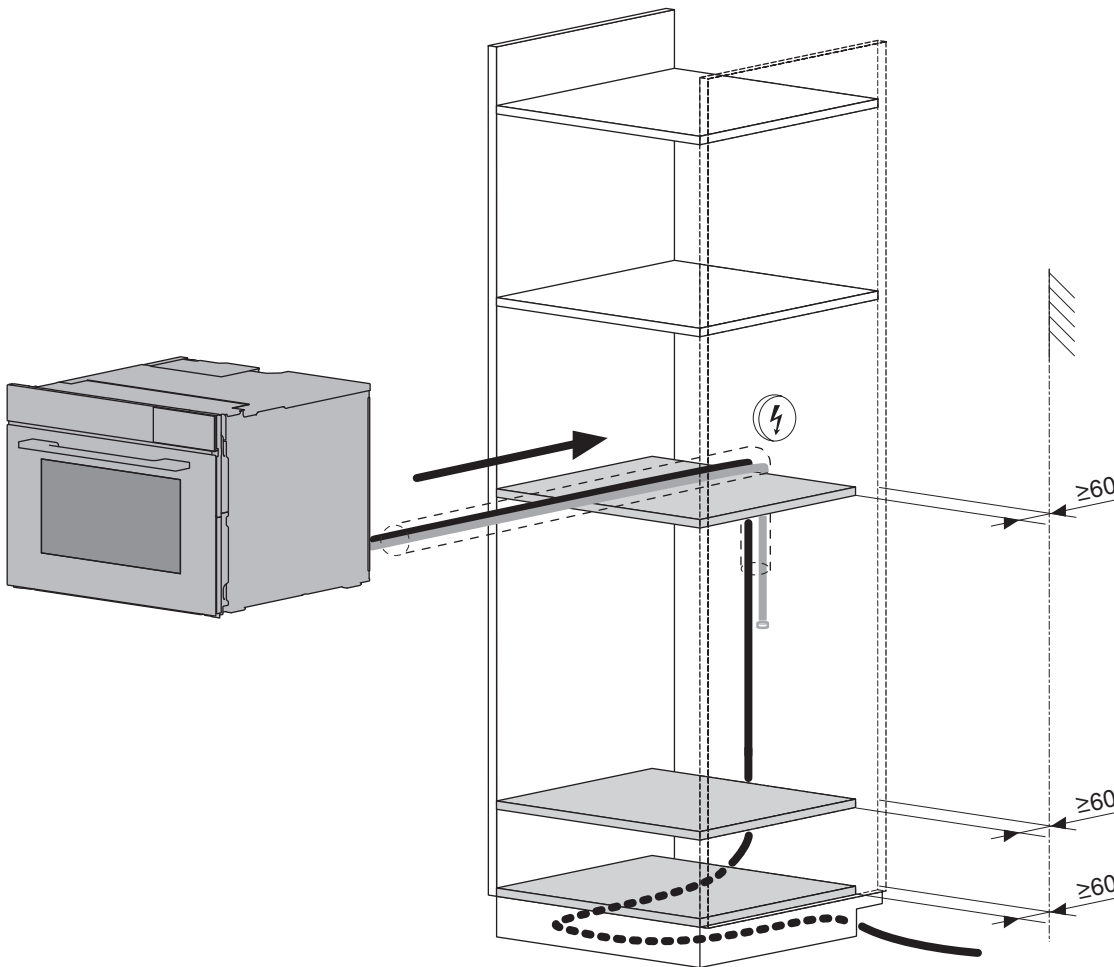

Plumbing in

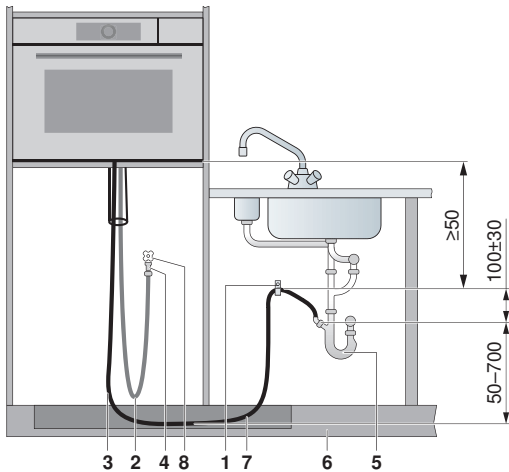

- 1 Hose clamp
- 2 Reinforced inlet hose 2 m, G³/₄"
- 3 Drain hose 3 m, internal diameter of connection 22 mm
- 4 Backflow preventer

On-site installations

- 5 Drain trap
- 6 Plinth panel
- 7 Hose fed through plinth
- 8 Cold water connection with stopcock

Drain

- Length of drain hose: 3 m. An optional 5 m drain hose (Art. no. 1012933) can be ordered if required.



The mounted drain hose must not be lengthened or shortened. The drop from the bottom of the appliance to the drain trap must be at least 50 mm. Install the drain hose without kinks and without any pressure or tension on it.

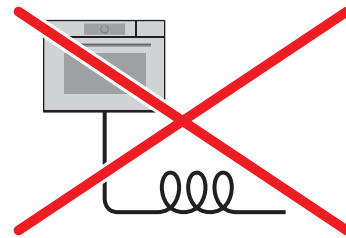

Cold water connection inlet

Operating pressure: 0.1–1.0 MPa (1–10 bar)

Only use if water hardness >3° French hardness (>1.7° German Hardness).

Length of reinforced hose: 2 m



Observe local water authority regulations. Existing hoses that are defective must be replaced. The inlet hose must not be shortened or damaged. Should the flexible inlet hose not be long enough, then a rigid extension of the on-site installation is required. The stopcock must be accessible at all times.

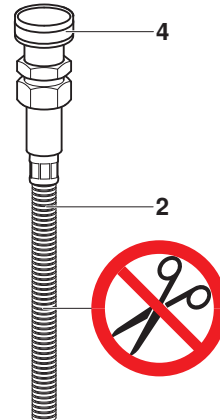

Due to a standards requirement, the appliances must be connected to the drinking water supply by means of the backflow preventer (1278183) supplied.

3 Ovens

3.1 General notes



Efficient repairs can only be guaranteed if it is possible to uninstall the whole appliance at any time without causing any damage.

The niche and gap dimensions given below must be observed to ensure proper ventilation.

3.2 Electrical connection data



General information on the electrical connections and an overview of the positions can be found in section Overview of connections, ranges and dimensions (see page 5).

Appliance	Model number	Mains connection	Fuse	Connection cable	Mains cable
Comhair V2000 45	21048	220–240 V~ 50 Hz	16 A	3400 W	min. 1.8 m, without plug
Comhair V4000 45/45P	21048, 21058				
Comhair V6000 45/45P	21050, 21059, 21067, 21070				
Comhair V2000 60	21043				
Comhair V4000 60/60P	21045, 21055				
Comhair V6000 60/60P	21047, 21057, 21068, 21073				

3.3 Excellence Line 60 cm

Oven

Comhair V2000 60, Comhair V4000/V6000 60/60P, niche height 600

Valid for the following models: 21043, 21045, 21047, 21055, 21057, 21068, 21073

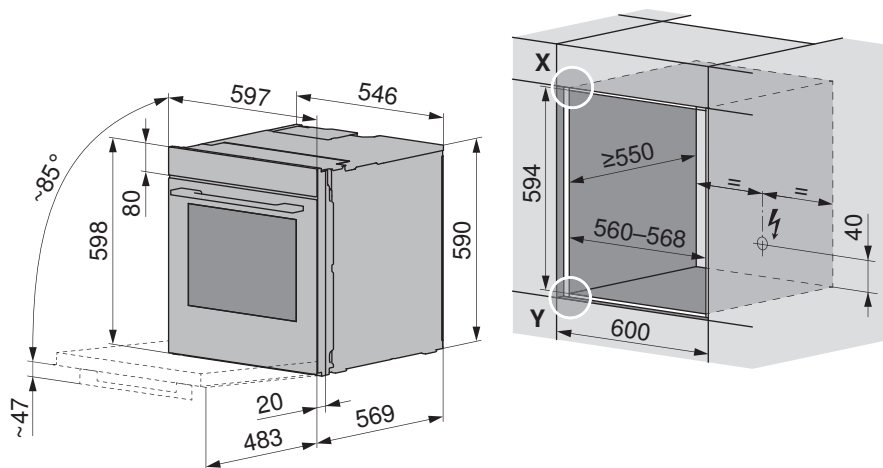

Front dimensions of the appliances: Detail X/Y (see page 11)

Compact oven

Comhair V2000 45, Comhair V4000/V6000 45/45P, niche height 450

Valid for the following models: 21048–21050, 21058, 21059, 21067, 21070

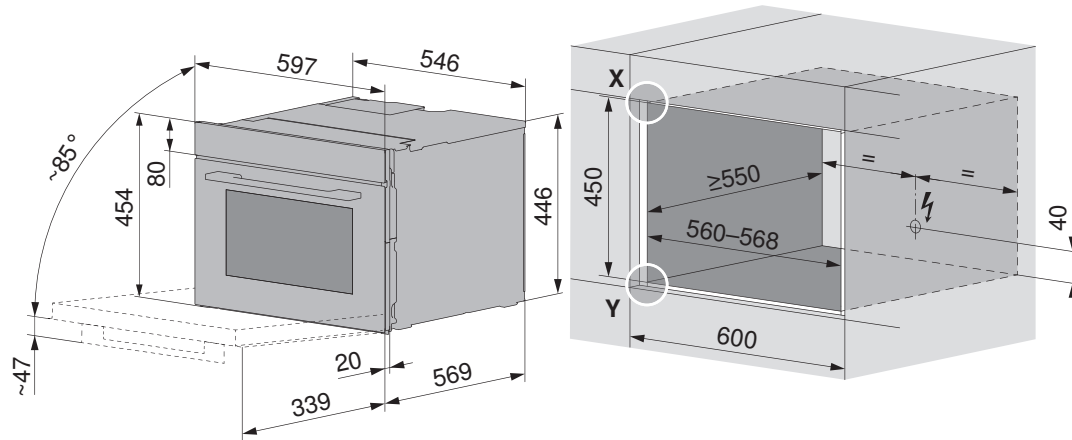

Front dimensions of the appliances: Detail X/Y (see page 11)

3.4 Advanced Line 60 cm

Oven

Comhair V600 60, niche height 600

Valid for the following model: 21128

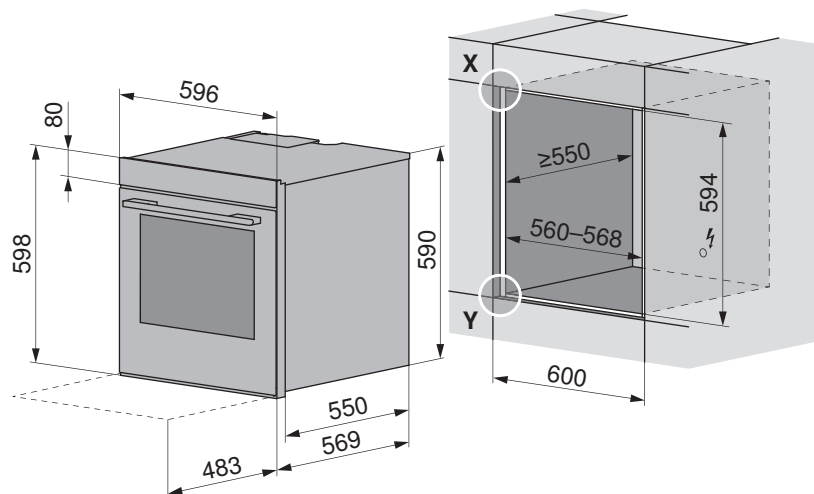

Front dimensions of the appliances: Detail X/Y



4 Vacuum drawers, warming drawers & system drawers

4.1 General notes



Efficient repairs can only be guaranteed if it is possible to uninstall the whole appliance at any time without causing any damage.

4.2 Electrical connection data



Plan a separate inlet for the electrical connection for each appliance.



General information on the electrical connections and an overview of the positions can be found in section Overview of connections, ranges and dimensions (see page 5).

Appliance	Mains connection	Fuse	Rated load	Mains cable
Vacuum drawers	220–240 V~ 50 Hz	10 A	320 W	1.7 m, with plug
Warming drawers			810 W	

4.3 Vacuum drawers



The Angle set for combination possibilities and Anti-tip set for VacuDrawer V6000 (see page 127) are not included in the scope of delivery. Anti-tip set for VacuDrawer V6000 (see page 127) An Anti-tip set for VacuDrawer V6000 (see page 127) must be ordered if there is a **coffee-center** or **no** appliance is installed above the vacuum drawer.



For installation next to warming drawer, order Trim kit (edge protection) (see page 126) at the same time.



For installation with a CombiSteamer with fixed water connection, an installation depth of ≥ 575 mm must be taken into account (see page 15).

VacuDrawer V6000 (36004) Built-in solo

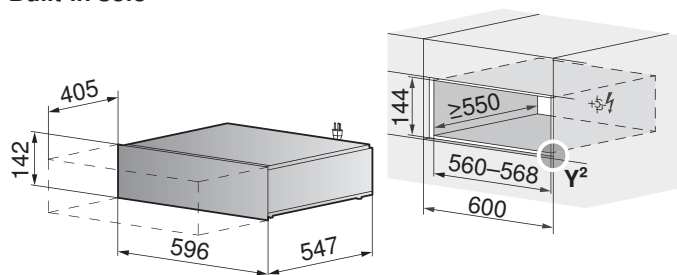

VacuDrawer V6000 (36005) Built-in solo, fully integrated

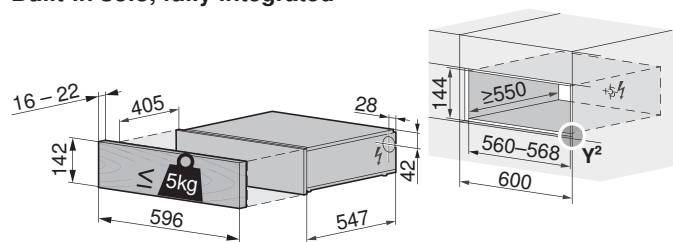

Installing with compact oven or steamer

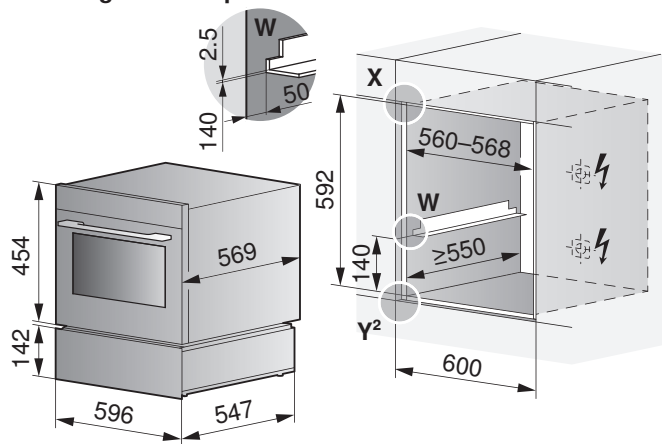

Installing with oven & compact oven or steamer

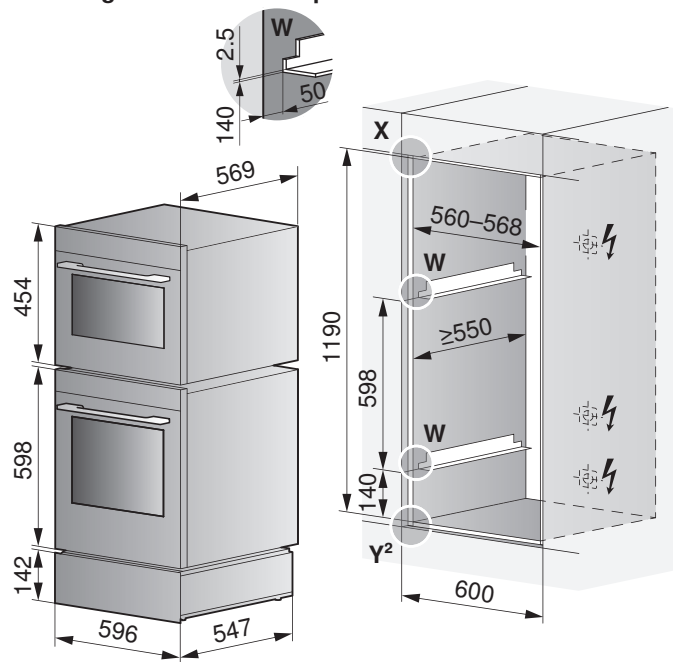

Front dimensions of the appliances: Detail X/Y² (see page 11)

Installing the vacuum drawer below the kitchen worktop correctly



Do not install appliance behind a cabinet door.

If the kitchen worktop protrudes too far out from the cabinet, it could collide with the **glass lid** of the vacuum drawer. Observe the dimensions table.

Design integrated

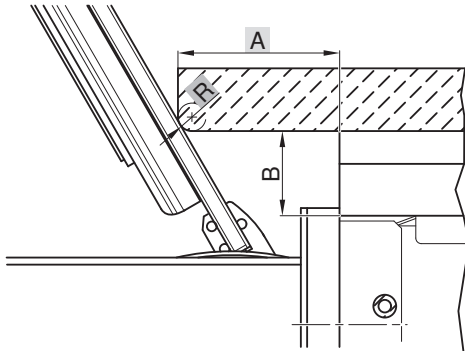

		R [mm]						
		0	2	4	6	8	10	
A [mm]	36	5.528						B [mm]
	38	8.992	7.528	6.064				
	40	12.456	10.992	9.528	8.064	6.600	5.136	
	42	15.920	14.456	12.992	11.528	10.064	8.600	
	44	19.384	17.920	16.456	14.992	13.528	12.064	
	46	22.848	21.384	19.920	18.456	16.992	15.528	
	48	26.313	24.848	23.384	21.920	20.456	18.992	
	50	29.777	28.313	26.848	25.384	23.920	22.456	
	52	33.241	31.777	30.313	28.848	27.384	25.920	
	54	36.705	35.241	33.777	32.313	30.848	29.384	
	56	40.169	38.705	37.241	35.777	34.313	32.848	
	58	43.633	42.169	40.705	39.241	37.777	36.313	
60	47.097	45.633	44.169	42.705	41.241	39.777		



Fully integrated

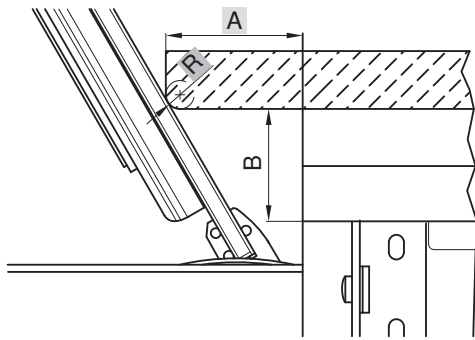

		R [mm]					
		0	2	4	6	8	10
A [mm]	24	7.850	6.386				
	26	11.314	9.850	8.386	6.922	5.458	
	28	14.778	13.314	11.850	10.386	8.922	7.458
	30	18.243	16.778	15.314	13.850	12.386	10.922
	32	21.707	20.243	18.778	17.314	15.850	14.386
	34	25.171	23.707	22.243	20.778	19.314	17.850
	36	28.635	27.171	25.707	24.243	22.778	21.314
	38	32.099	30.635	29.171	27.707	26.243	24.778
	40	35.563	34.099	32.635	31.171	29.707	28.243
	42	39.027	37.563	36.099	34.635	33.171	31.707
	44	42.491	41.027	39.563	38.099	36.635	35.171
	46	45.955	44.491	43.027	41.563	40.099	38.635
48	49.419	47.955	46.491	45.027	43.563	42.099	

B [mm]

Special installation situations can be obtained here.



4.4 Warming drawers



The mounting angles are not included in the scope of delivery. Order angle set K50572 at the same time.

WarmingDrawer V4000 14 (34026)
Built-in solo

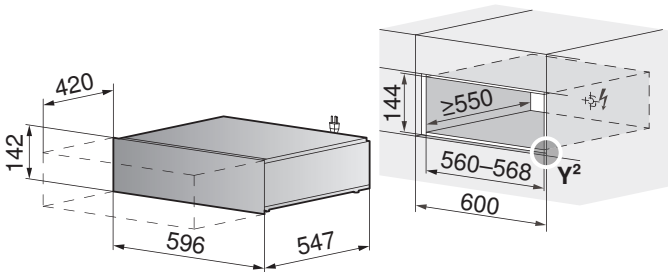

WarmingDrawer V4000 14 (34027)
Built-in solo, fully integrated

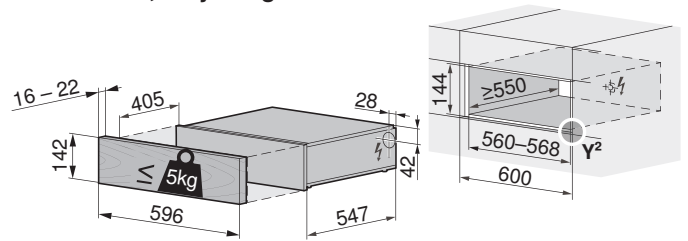

Installing with compact oven or steamer

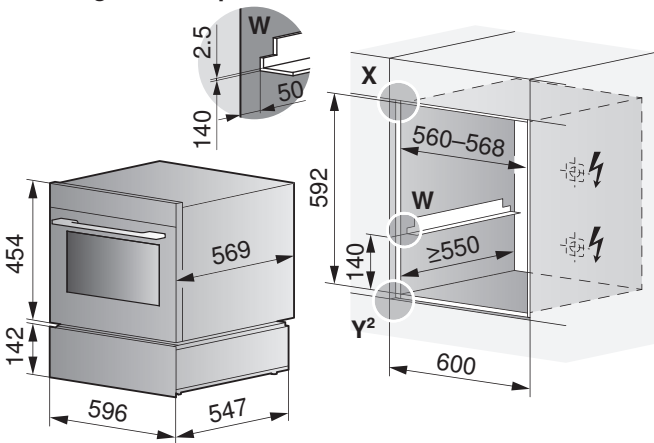

Installing with oven & compact oven or steamer

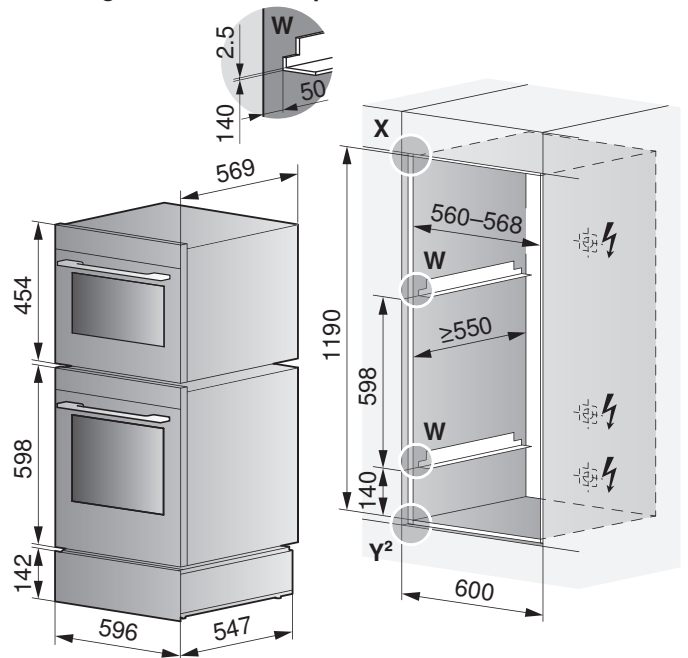

Front dimensions of the appliances: Detail X/Y²

WarmingDrawer V4000 22 (34029)

Built-in solo

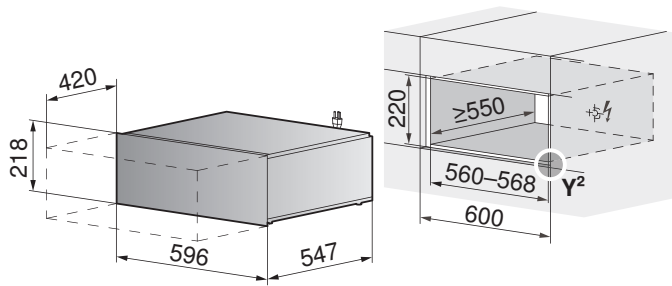

Installing with steamer

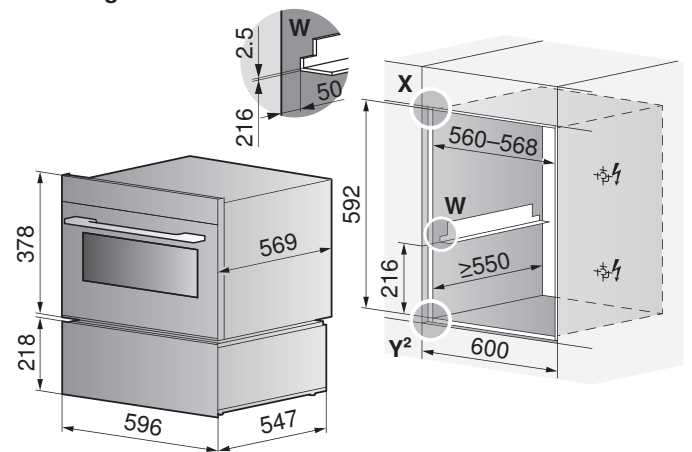

WarmingDrawer V4000 28 (34030)

Built-in solo

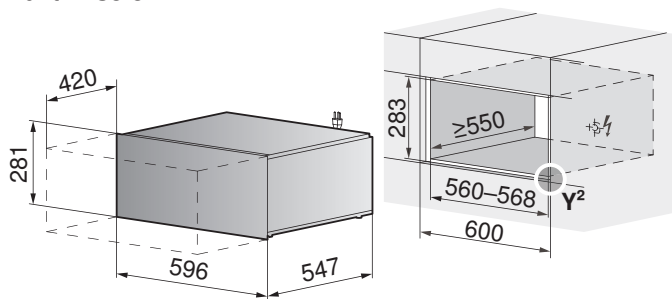

Installing with oven

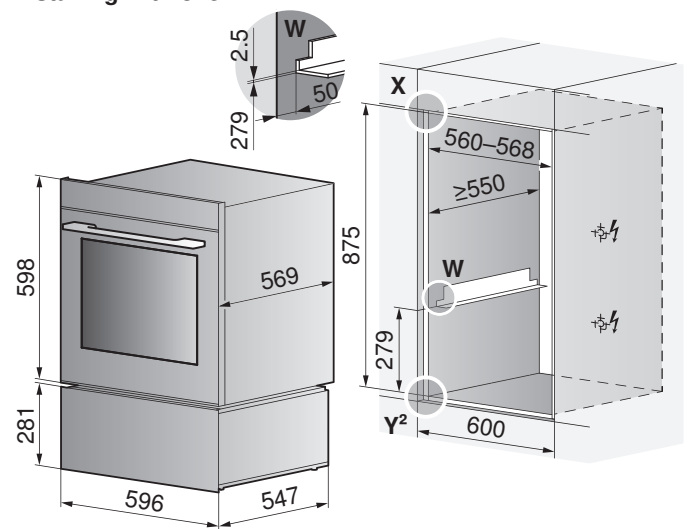

Front dimensions of the appliances: Detail X/Y²

WarmingDrawer V4000 31 (34031)

Built-in solo

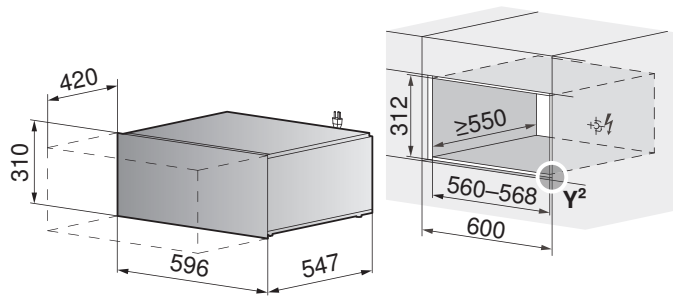

Installing with oven

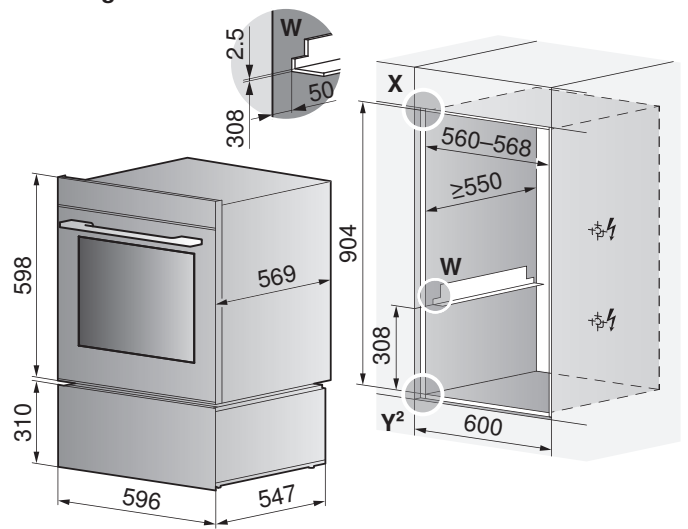

Front dimensions of the appliances: Detail X/Y²

4.5 System drawers

Drawer V2000 14 (35005)

Installing with coffee-center

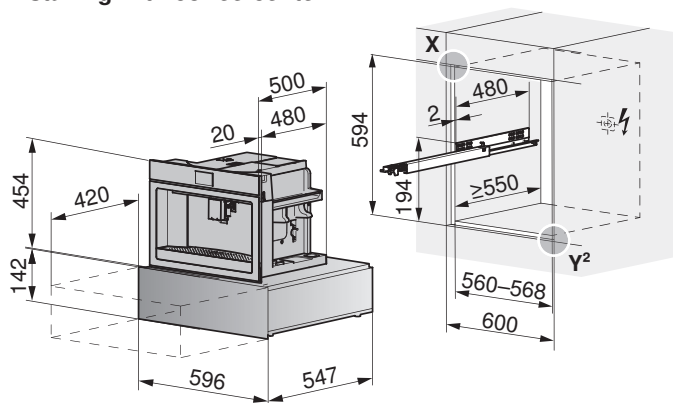

Front dimensions of the appliances: Detail X/Y² (see page 11)

 The telescopic runner for the assembly and operation of the coffee-center is included in the scope of delivery of the coffee-center.

6 Automatic built-in coffee machines

6.1 General notes



Efficient repairs can only be guaranteed if it is possible to uninstall the whole appliance at any time without causing any damage.

6.2 Electrical connection data



General information on the electrical connections and an overview of the positions can be found in section Overview of connections, ranges and dimensions (see page 5).

Mains connection	Fuse	Rated load	Mains cable
220–240 V~ 50–60 Hz	10 A	1350 W	1.5 m, with plug

6.3 CoffeeCenter V6000 45 (25005)

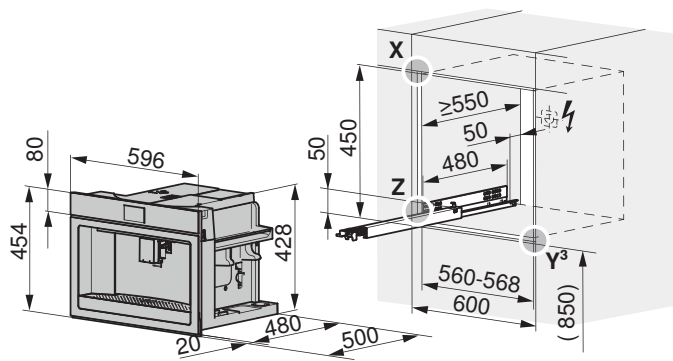

Detail Y³

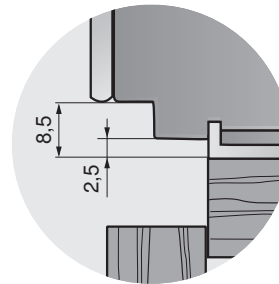

Detail Z

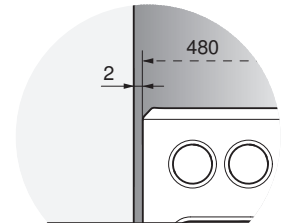

Front dimensions of the appliances: Detail X (see page 11)

7 Combination possibilities



General information on the electrical connections and an overview of the positions can be found in section Overview of connections, ranges and dimensions (see page 5).

7.1 Oven & steam cooker



If installing with a second appliance in the same niche, use angle set W (K50572). The mounting angles are not included in the scope of delivery.

Oven/Steamer & compact oven / steamer

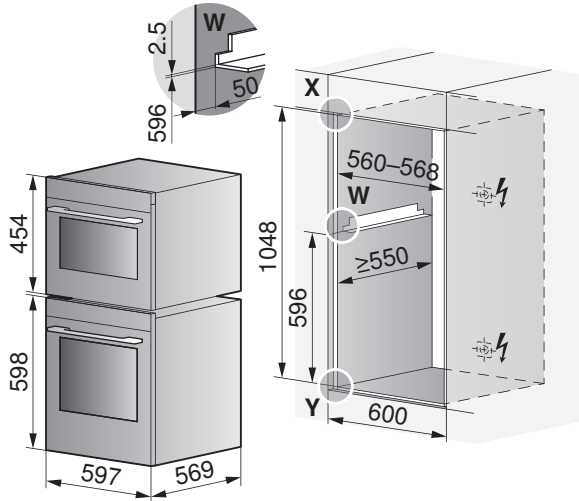

Oven/Steamer & compact oven & steamer

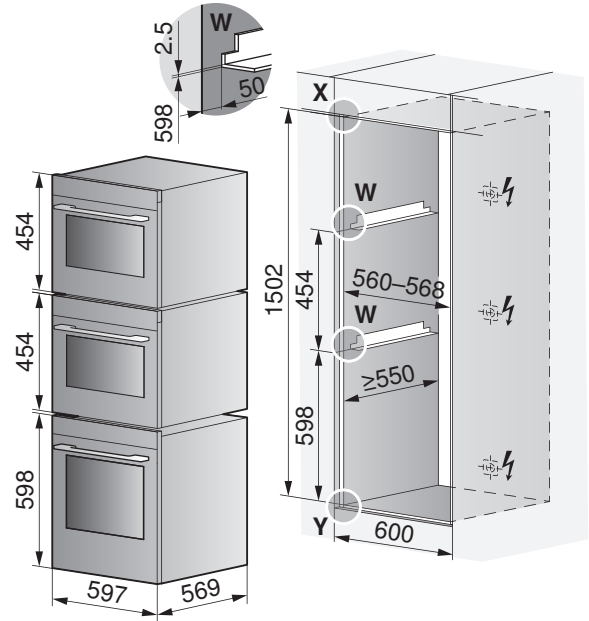

Front dimensions of the appliances: Detail X/Y (see page 11)

Compact oven & steamer

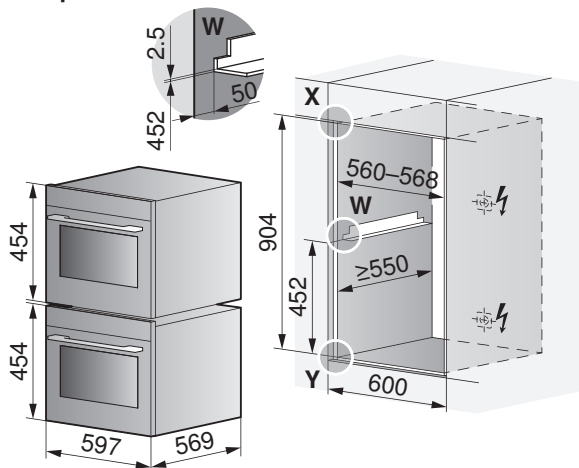

Front dimensions of the appliances: Detail X/Y (see page 11)



If installing with a second appliance in the same niche, use angle set **W** (K50572). The mounting angles are not included in the scope of delivery.

CombiSteamer V6000 45L Grand – Installation in double niche

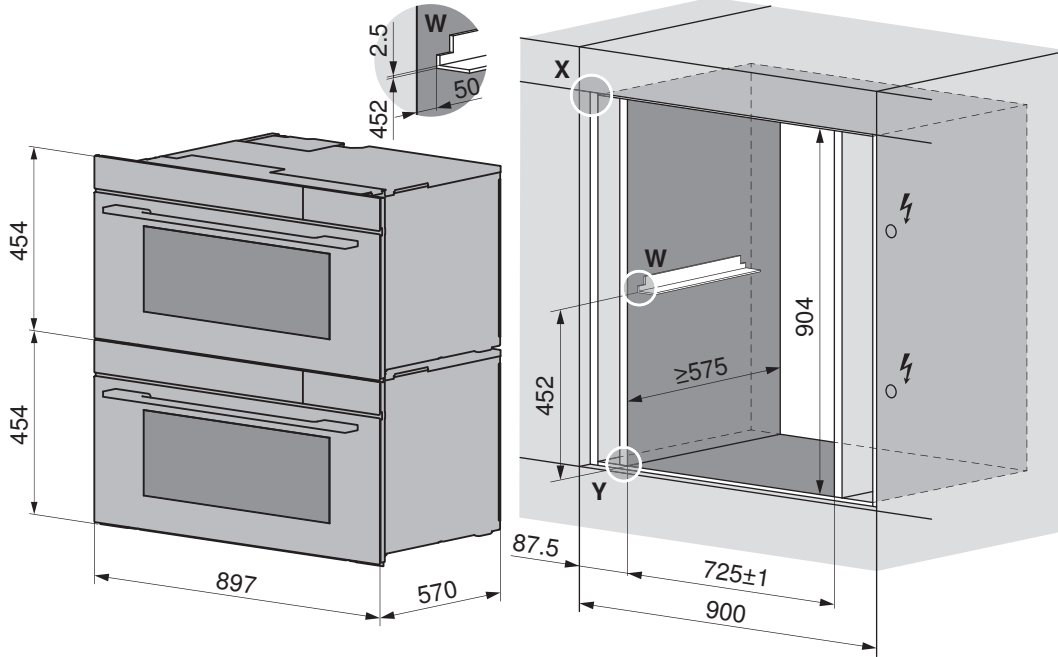

Front dimensions of the appliances: Detail X/Y (see page 11)

7.2 Oven & microwave oven



Minimum installation height for child safety: Keep 850 mm distance from the floor to the bottom edge of the microwave oven!



Niche ventilation can also be provided through a shadow gap with an appropriate cross-section. For more information, see the Niche ventilation (see page 114) section.



If installing with a second appliance in the same niche, use angle set **W** (K50572). The mounting angles are not included in the scope of delivery.

CombiMiwell V4000 45 & oven/steamer

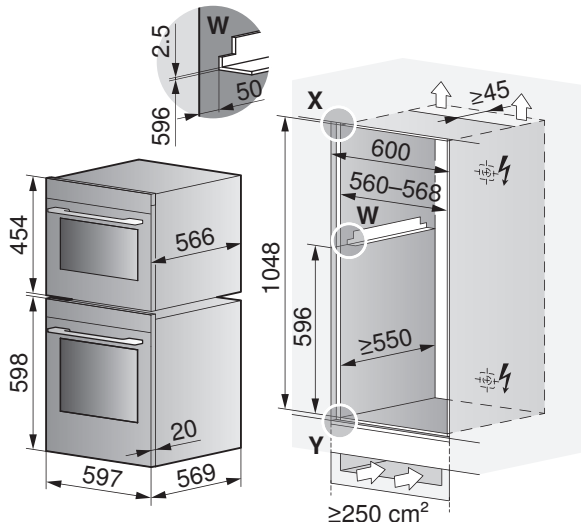

CombiMiwell V4000 45 & oven/steamer

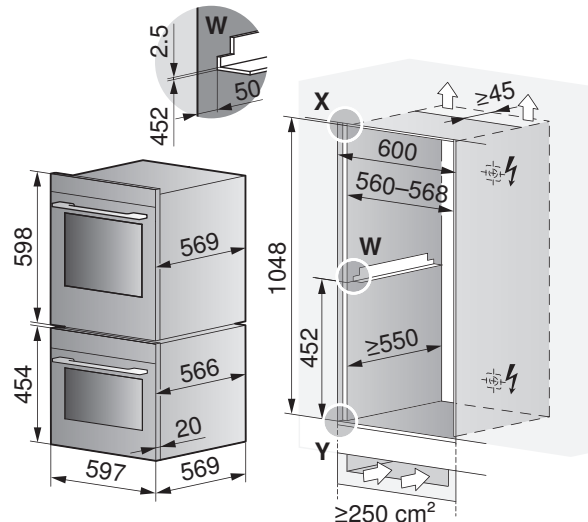

Front dimensions of the appliances: Detail X/Y (see page 11)



If installing with a second appliance in the same niche, use angle set **W** (K50572). The mounting angles are not included in the scope of delivery.

CombiMiwell V4000 45 & mini oven / steamer

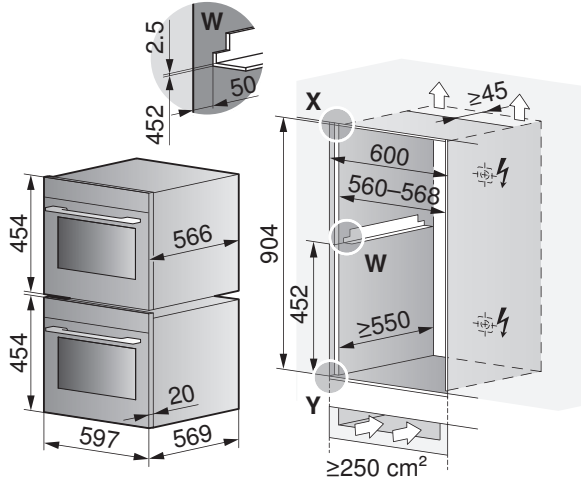

Front dimensions of the appliances: Detail X/Y (see page 11)

7.3 Oven & automatic built-in coffee machine



The telescopic runner for the assembly and operation is included in the scope of delivery.

CoffeeCenter V6000 45 & oven/steamer

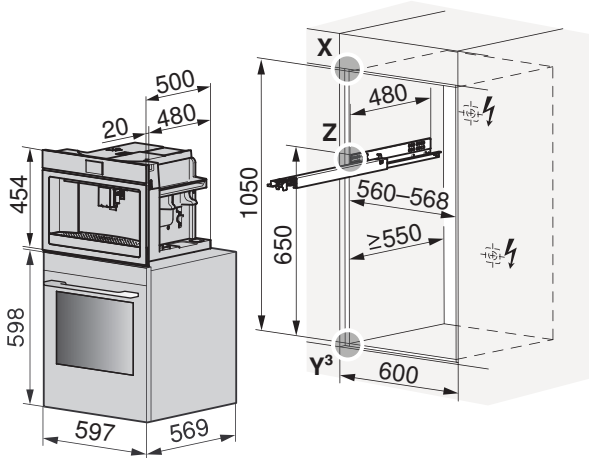

Front dimensions of the appliances: Detail X (see page 11)
 Internal dimension of the appliance: Detail Y³/Z (see page 28)

CoffeeCenter V6000 45 & compact oven / steamer

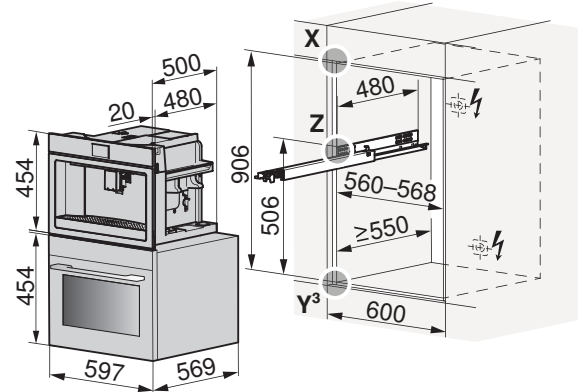

8 CookTop glass ceramic hobs

8.1 General notes



Induction hobs require adequate ventilation (see page 33).

If a drawer is installed directly underneath, a protective plate is recommended in the vicinity of the mains cable and to protect the ventilation openings. The ventilation protective plate set can be used for this purpose. Accessories (see page 128).



Efficient repairs can only be guaranteed if it is possible to uninstall the whole appliance at any time without causing any damage.

The layout of the hobs to be installed may differ from the hobs illustrated here!

8.2 OptiGlass coating

Halogen or LED light bulbs are recommended for illuminating hobs with the OptiGlass coating. The use of fluorescent tube lighting to illuminate hobs with the OptiGlass coating causes the glass surface to shimmer.

8.3 Electrical connection data



General information on the electrical connections and an overview of the positions can be found in section Overview of connections, ranges and dimensions (see page 5).

Appliance	Mains connection	Fuse	Rated load	Mains cable
CookTop Teppan Yaki I40	220–240 V~ 50–60 Hz	16 A	2800 W	1.7 m, without plug
CookTop V4000 I402			3700 W	
CookTop V4000 I604/I704/I804		32 A	7400 W	
CookTop V4000 I904	220–240 V~ 50–60 Hz	32 A	7400 W	
CookTop V6000 I905	380–415 V 3N~ 50–60 Hz	16 A	11100 W	
CookTop V6000 I906 FullFlex	380–415 V 3N~ 50–60 Hz	16 A	11100 W	
CookTop V6000 I705 FullFlex	220–240 V~ 50–60 Hz	32 A	7400 W	

8.4 Ventilation

For installation of a V-ZUG induction hob, the following minimum requirements apply:

1. The hot air exhaust should be provided by a ventilation slit of ≥ 2 mm at the front.
2. A space of ≥ 10 mm in height is required beneath the appliance.
3. Not only exhaust air but also replacement air in the cabinet should be taken into account. There are different ways to do this, including:
 - a) The rear panel of the base unit must be open around the work surface cut-out to guarantee continuous air circulation through the ventilation slits. The air must be drawn in from outside the cabinet and be able to circulate freely from inside the cabinet to the hob. The lower plinth must not be hermetically sealed. This can be achieved through a shadow gap at the plinth panel or through the use of a ventilation grille.
 - b) Alternatively, a concealed fresh air supply can ensure air circulation inside the cabinet. In order that enough cold air can be drawn in, there must be a continuous circulation of fresh air that extends outside the cabinet. The lower drawer panel should therefore not hermetically seal the cabinet.

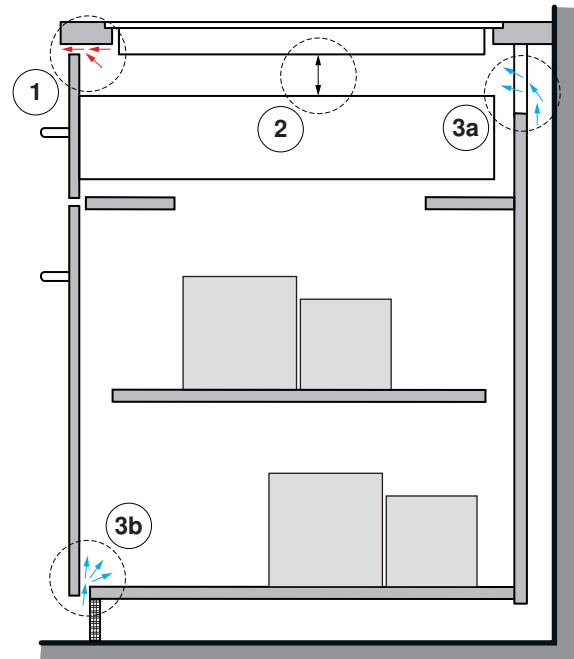

Recommendation

If the hob is being used at the power limit, a reduction in power after a certain amount of time is normal. All induction hobs available on the market can be observed to work in the same way. Should, through cooking behaviour, such an instance occur more often, performance can be improved by optimizing ventilation. To this end, the installation of a ventilation protective plate with seal is generally recommended (see page 48).

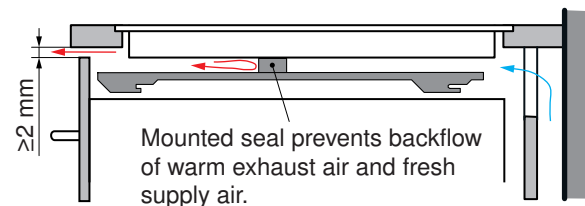

Ventilation protective plates only achieve the desired effect with the seal in place. The foam seals are available separately so that protective plates from other manufacturers can be retrofitted (see page 128).

8.5 Surface-mounted installation with «DualDesign»



The installation of a ventilation protection plate with seal is strongly recommended.



- Corner radii of cut-out, aim for ≤ 5 mm
- Corner radii of appliance 2 mm

CookTop V6000 I906 FullFlex (31134)

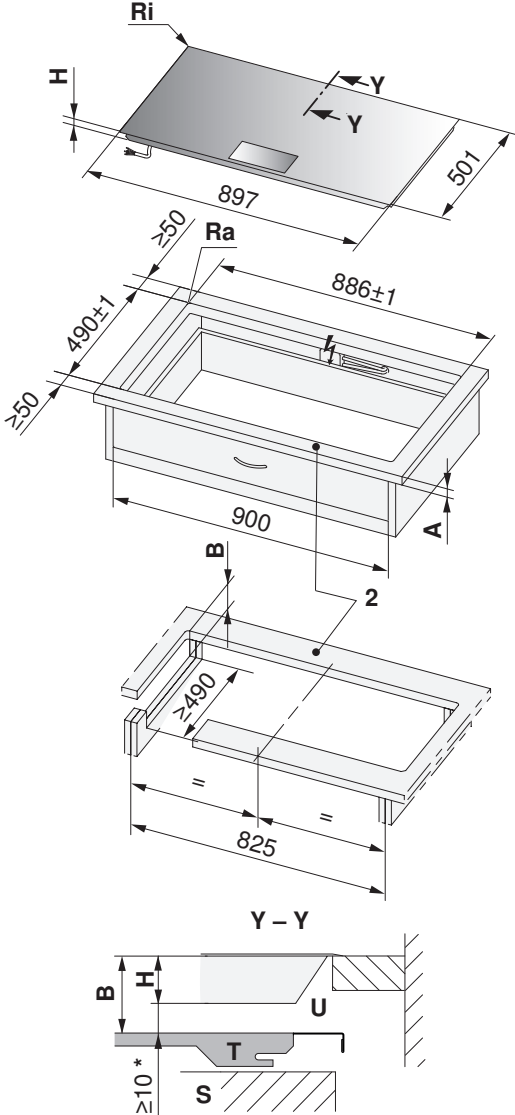

CookTop V6000 I705 FullFlex (31132)

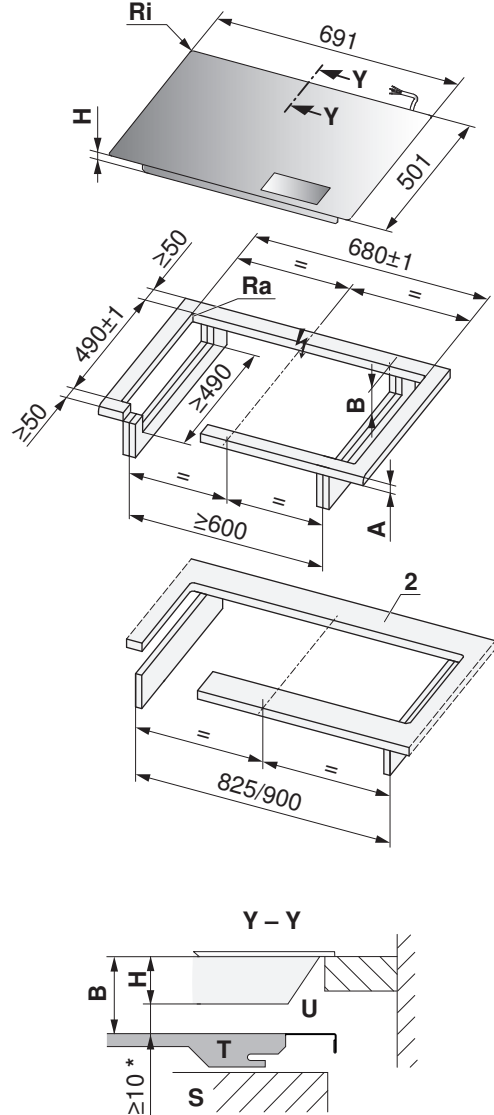

* The required clearance must be observed!

2 Front and rear struts are reinforced on the underside. The strut width is determined by the producer of the stone worktop. The minimum strut width can vary according to the property of the stone.

Type	A Depends on producer	B	H	Corner radius Ra/Ri
CookTop V6000 I906 FullFlex, CookTop V6000 I705 FullFlex	≤ 40 mm	≥ 82 mm	72 mm	5/2 mm

- A** Worktop depth
- B** Required clearance for service replacement over the entire cut-out area.
- H** Dimension from the top of the work surface to the underside of the hob
- Ra** Outer corner radii of cut-out
- Ri** Corner radii of appliance
- S** Drawer/Cabinet
- T** Ventilation protective plate
- U** Air inlet

Surface-mounted installation with «DualDesign»



- Corner radii of cut-out, aim for ≤ 5 mm
- Corner radii of appliance 2 mm

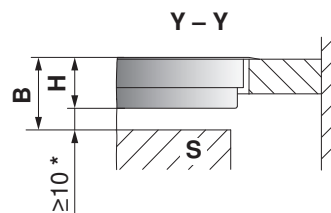
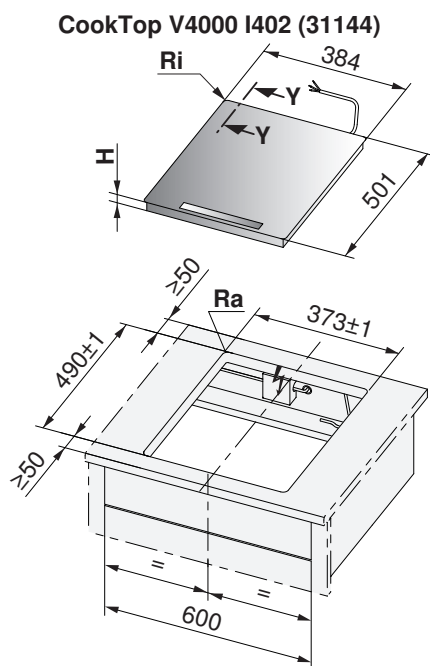

* The required clearance must be observed!

Type	B	H	Corner radius Ra/Ri
CookTop V4000	≥ 61.7 mm	51.7 mm	5/2 mm

- B** Required clearance for ventilation and service replacement over the entire cut-out area.
- H** Dimension from the top of the work surface to the underside of the hob (ventilation opening)
- Ra** Outer corner radii of cut-out
- Ri** Corner radii of appliance
- S** Drawer/Cabinet

Surface-mounted installation with «DualDesign»



- Corner radii of cut-out, aim for ≤ 5 mm
- Corner radii of appliance 2 mm

CookTop Teppan Yaki I40 (31140)

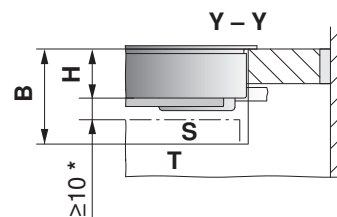
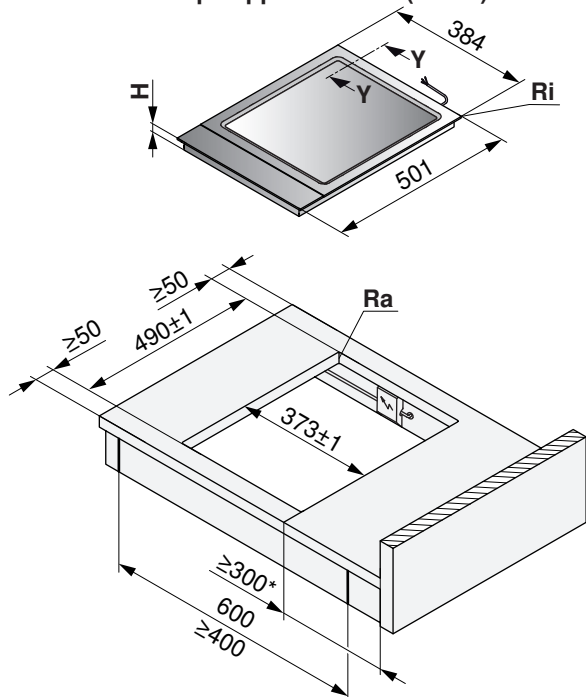

* On both sides for technical reasons.

Type	B	H	Corner radius Ra/Ri
CookTop Teppan Yaki	≥ 74 mm	64 mm	0–5/2 mm

- B** Required clearance for ventilation and service replacement over the entire cut-out area.
- H** Dimension from the top of the work surface to the underside of the hob (ventilation opening)
- Ra** Outer corner radii of cut-out
- Ri** Corner radii of appliance
- S** Drawer/Cabinet
- T** Side wall

Combination installation

For surface-mounted combination installation, the side strip set 1028587 and the intermediate support 1014361 (stainless steel) or 1019199 (black) are needed.

► The side strips must be fixed on the left-hand and right-hand side of the appliance with four screws on each side.

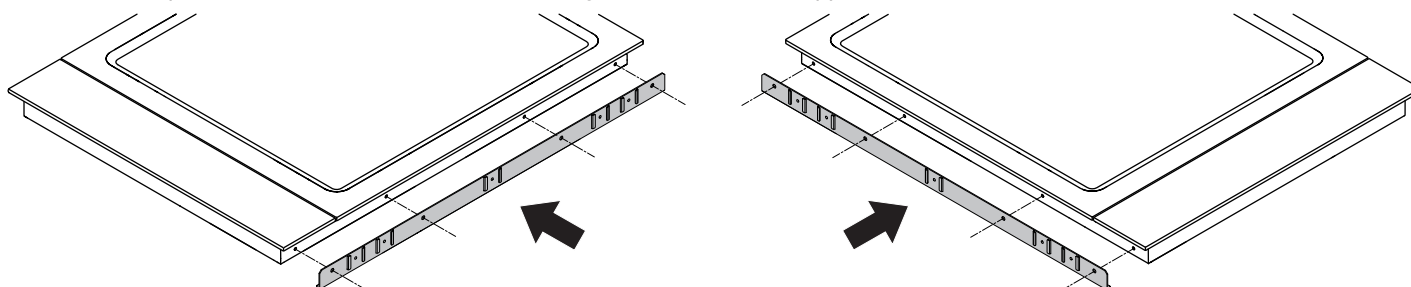

Surface-mounted combination installation is described in document 1013770.

Surface-mounted installation with «DualDesign»



- Corner radii of cut-out, aim for ≤ 5 mm
- Corner radii of appliance 2 mm

**CookTop V2000 I604 (31179),
 CookTop V4000 I604 (31115/31157)**

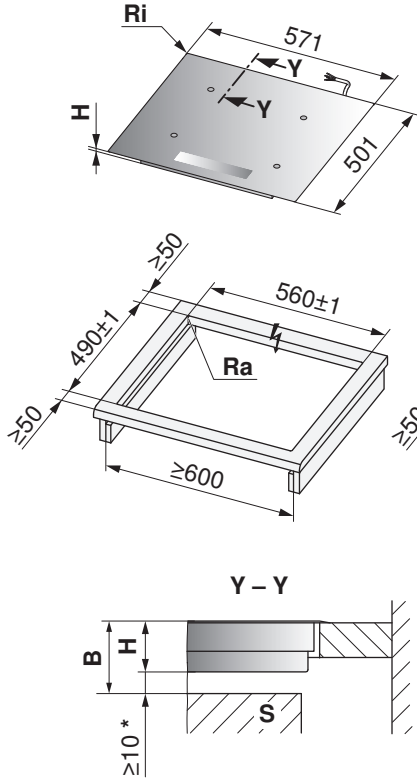

CookTop V4000 I704 (31116)

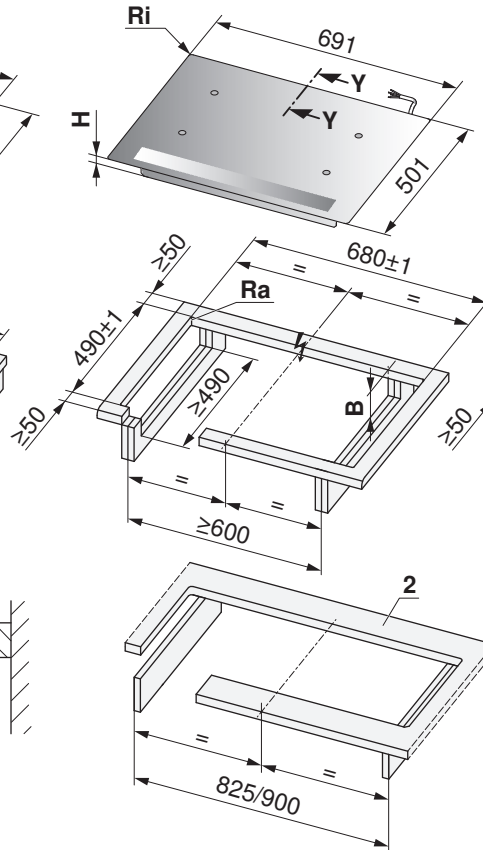

**CookTop V2000 I804 (31182),
 CookTop V4000 I804 (31158)**

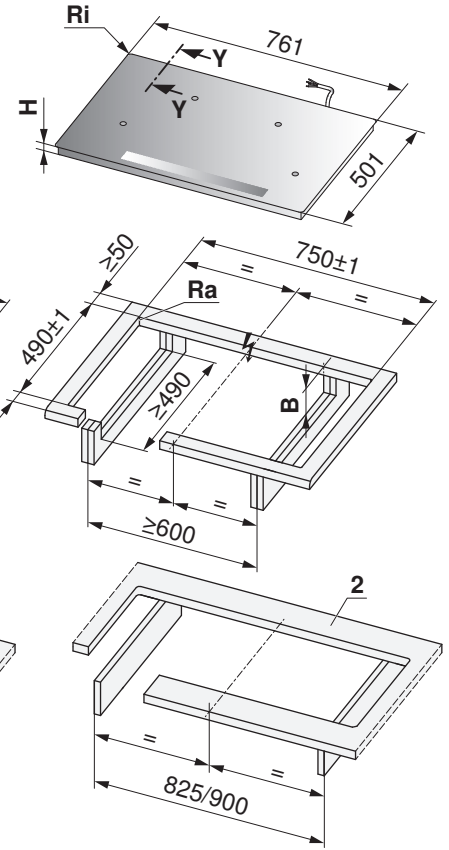

* The required clearance must be observed!

2 Front and rear struts are reinforced on the underside. The strut width is determined by the producer of the stone worktop. The minimum strut width can vary according to the property of the stone.

Type	B	H	Corner radius Ra/Ri
CookTop V2000 (31179, 31182)	≥ 71 mm	47.7 mm	5/2 mm
CookTop V4000 (31115, 31116)	≥ 60 mm	50 mm	5/2 mm
CookTop V4000 (31157, 31158)	≥ 58 mm	48 mm	5/2 mm

- B** Required clearance for ventilation and service replacement over the entire cut-out area.
- H** Dimension from the top of the work surface to the underside of the hob (ventilation opening)
- Ra** Outer corner radii of cut-out
- Ri** Corner radii of appliance
- S** Drawer/Cabinet

Surface-mounted installation with «DualDesign»



- Corner radii of cut-out, aim for ≤ 5 mm
- Corner radii of appliance 2 mm

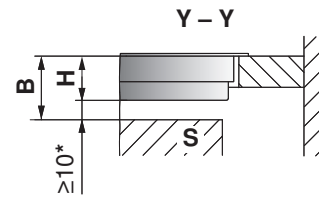
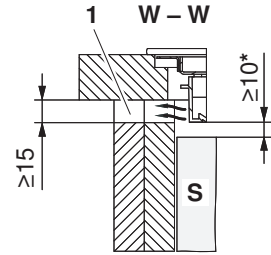
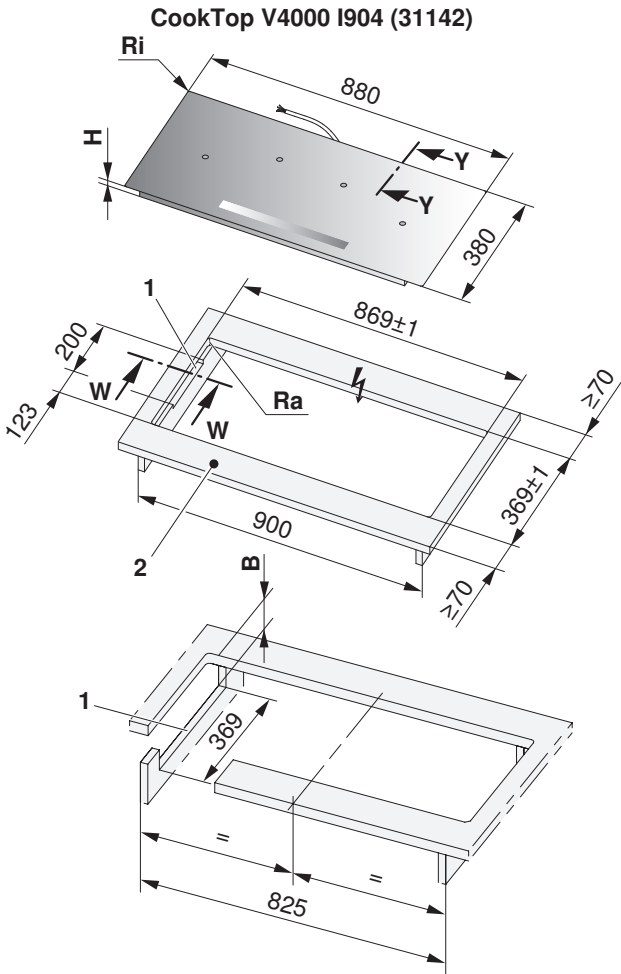

* The required clearance must be observed!

- 1 Mounting cut-outs in side walls left/right for a niche width of ≥ 900 mm, necessary for the ventilation of the appliance.
- 2 Front and rear struts are reinforced on the underside. The strut width is determined by the producer of the stone worktop. The minimum strut width can vary according to the property of the stone.

Type	B	H	Corner radius Ra/Ri
CookTop V4000	≥ 61 mm	51 mm	5/2 mm

- B** Required clearance for ventilation and service replacement over the entire cut-out area.
H Dimension from the top of the work surface to the underside of the hob (ventilation opening)
Ra Outer corner radii of cut-out
Ri Corner radii of appliance
S Drawer/Cabinet

Surface-mounted installation with «DualDesign»



- Corner radii of cut-out, aim for ≤5 mm
- Corner radii of appliance 2 mm

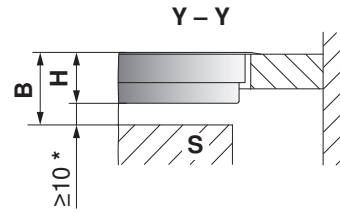
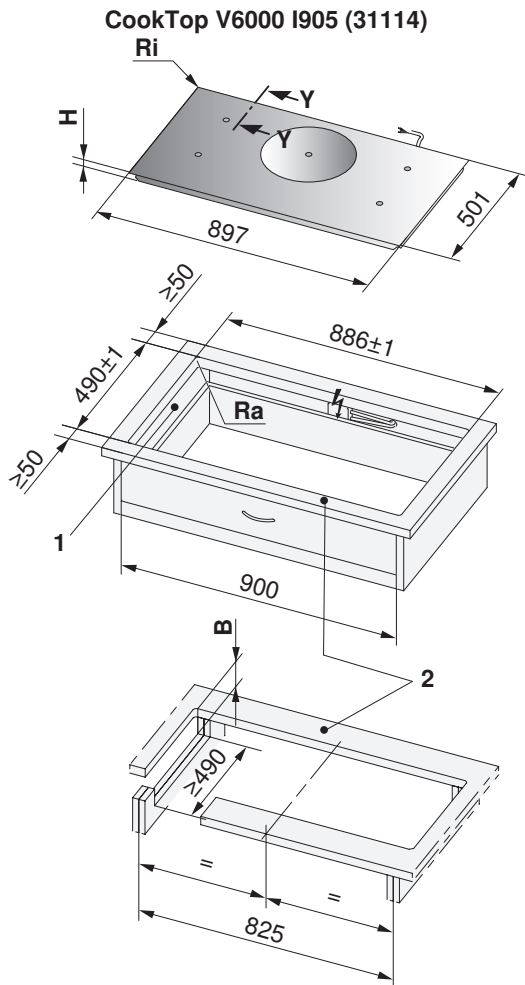

* The required clearance must be observed!

- 1 Mounting cut-outs in side walls left/right for a niche width of ≥900 mm, necessary for the ventilation of the appliance.
- 2 Front and rear struts are reinforced on the underside. The strut width is determined by the producer of the stone worktop. The minimum strut width can vary according to the property of the stone.

Type	B	H	Corner radius Ra/Ri
CookTop V6000	≥63.3 mm	53.3 mm	5/2 mm

- B** Required clearance for ventilation and service replacement over the entire cut-out area.
- H** Dimension from the top of the work surface to the underside of the hob (ventilation opening)
- Ra** Outer corner radii of cut-out
- Ri** Corner radii of appliance
- S** Drawer/Cabinet

8.6 Flush installation with «DualDesign»



Hob must be removable from below!



The installation of a ventilation protection plate with seal is strongly recommended.



- Corner radii of cut-out, aim for ≤ 5 mm
- Corner radii of appliance 2 mm

CookTop V6000 I906 FullFlex (31134)

CookTop V6000 I705 FullFlex (31132)

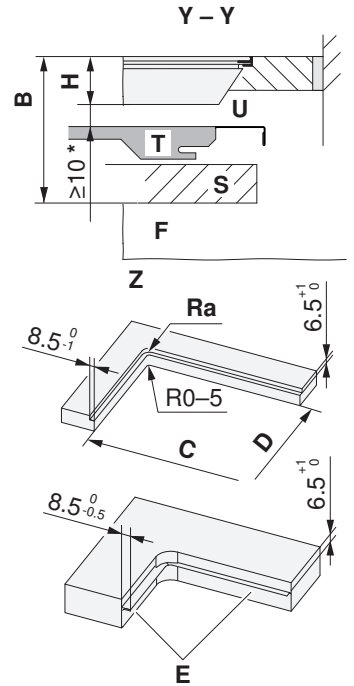
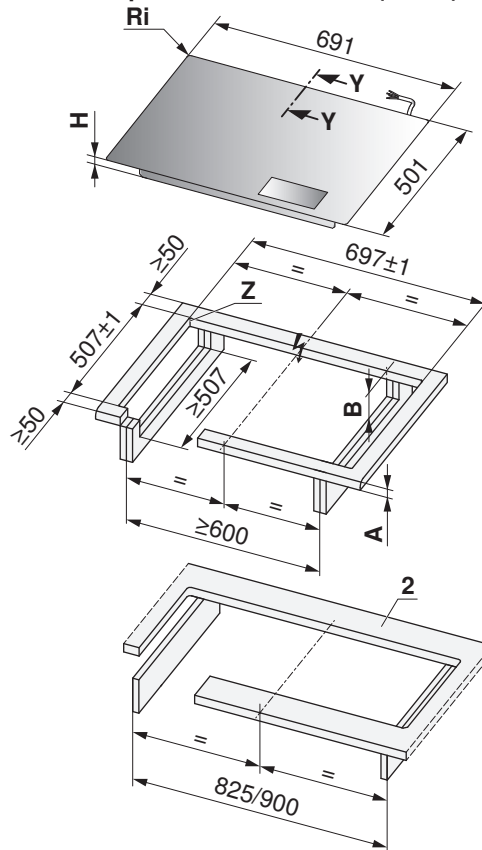
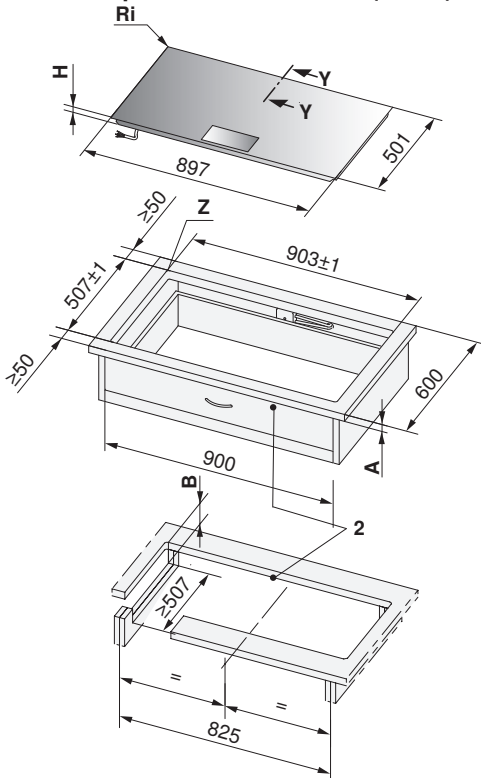

* The required clearance must be observed!

2 Front and rear struts are reinforced on the underside. The strut width is determined by the producer of the stone worktop. The minimum strut width can vary according to the property of the stone.

Type	A Depends on producer	B	C/D	H	Corner radius Ra/Ri
CookTop V6000 I906 FullFlex	≤ 40 mm	≥ 150 mm	886/490 mm	76 mm	5/2 mm
CookTop V6000 I705 FullFlex			680/490 mm		

- A** Worktop depth
- B** Required clearance for service replacement over the entire cut-out area.
- E** Steel angle bonded or screw mounted
- F** Side wall
- H** Dimension from the top of the work surface to the underside of the hob
- Ra** Outer corner radii of cut-out
- Ri** Corner radii of appliance
- S** Drawer/Cabinet
- T** Ventilation protective plate
- U** Air inlet

Flush installation with «DualDesign»



- Corner radii of cut-out, aim for ≤5 mm
- Corner radii of appliance 2 mm

CookTop Teppan Yaki I40 (31140)

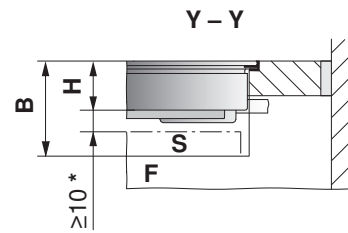
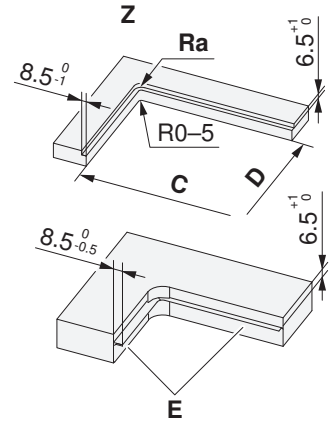
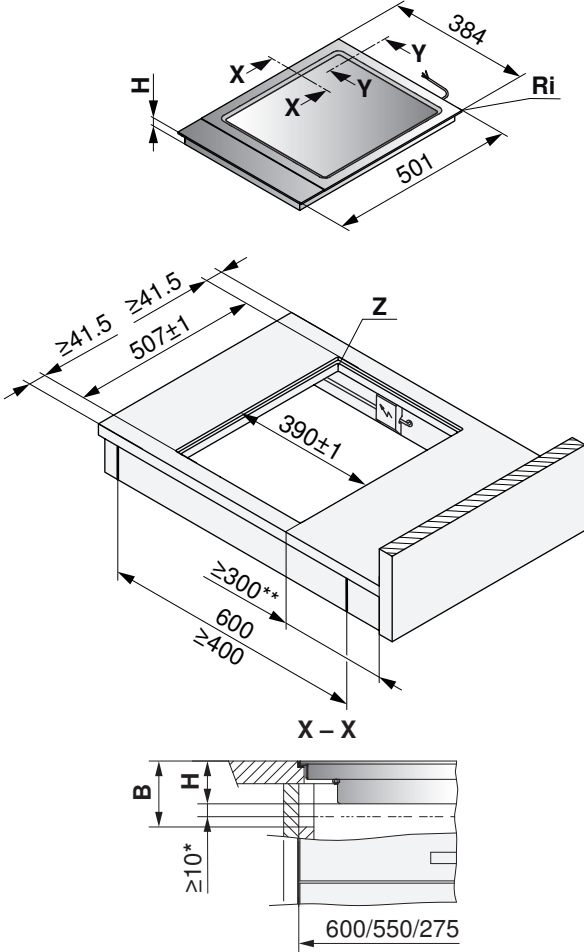

* The required clearance (for ventilation) must be observed!

** On both sides for technical reasons.

Type	B	C/D	H	Corner radius Ra/Ri
CookTop Teppan Yaki	≥73.6 mm	373/490 mm	64 mm	5/2 mm

- B** Required clearance for ventilation and service replacement over the entire cut-out area.
- E** Steel angle bonded or screw mounted
- F** Side wall
- H** Dimension from the top of the work surface to the underside of the hob (ventilation opening)
- Ra** Outer corner radii of cut-out
- Ri** Corner radii of appliance
- S** Drawer/Cabinet

Flush installation with «DualDesign»



- Corner radii of cut-out, aim for ≤ 5 mm
- Corner radii of appliance 2 mm

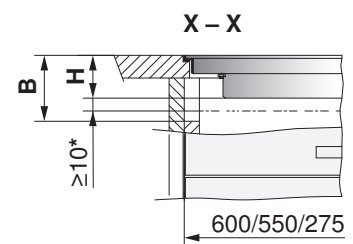
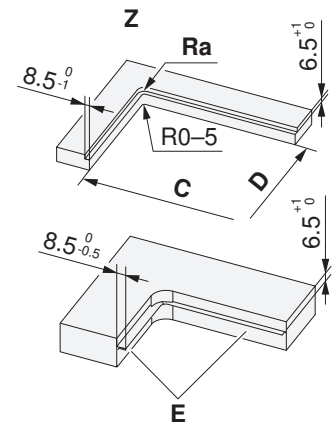
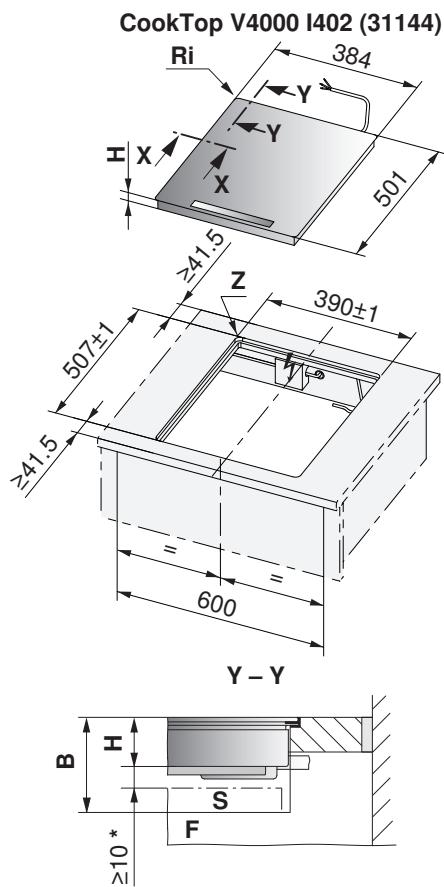

* The required clearance must be observed!

Type	B	C/D	H	Corner radius Ra/Ri
CookTop V4000	≥75 mm	373/490 mm	51.7 mm	5/2 mm

- B** Required clearance for ventilation and service replacement over the entire cut-out area.
- E** Steel angle bonded or screw mounted
- F** Side wall
- H** Dimension from the top of the work surface to the underside of the hob (ventilation opening)
- Ra** Outer corner radii of cut-out
- Ri** Corner radii of appliance
- S** Drawer/Cabinet



Flush installation with «DualDesign»



- Corner radii of cut-out, aim for ≤5 mm
- Corner radii of appliance 2 mm

**CookTop V2000 I604 (31179),
 CookTop V4000 I604 (31115/31157)**

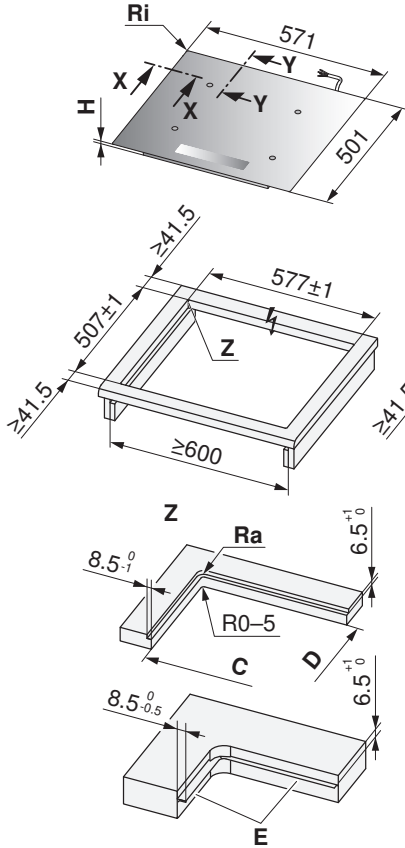

CookTop V4000 I704 (31116)

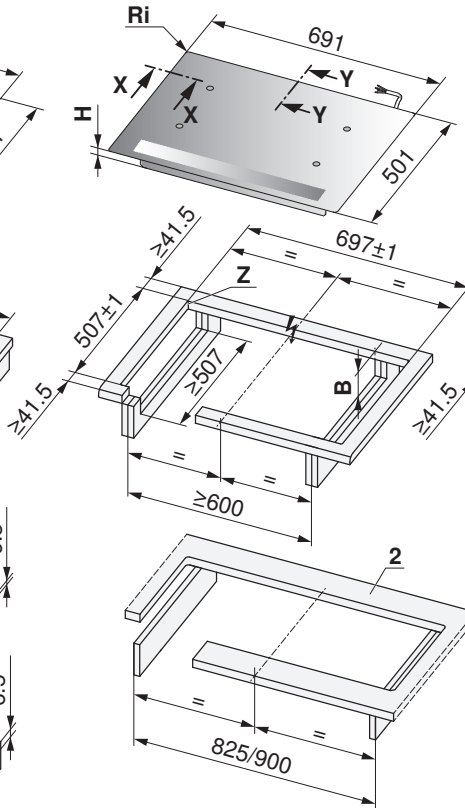

**CookTop V2000 I804 (31182),
 CookTop V4000 I804 (31158)**

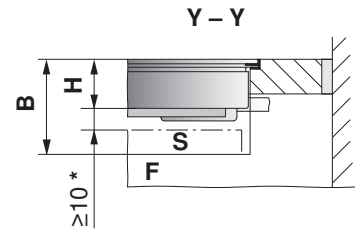
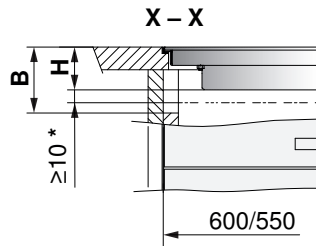
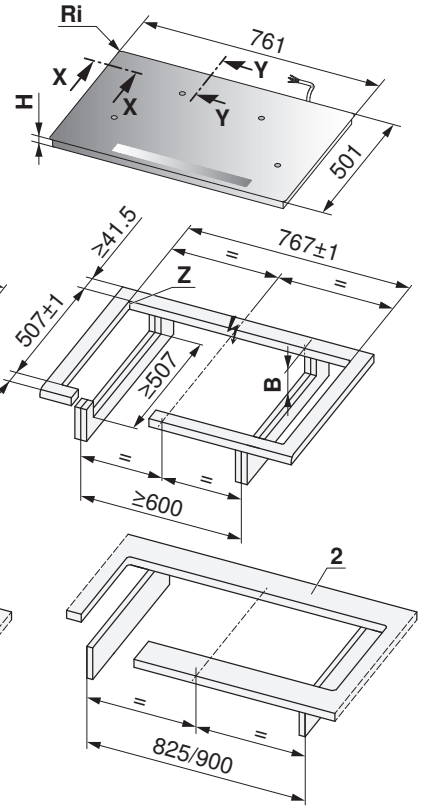

* The required clearance (for ventilation) must be observed!

2 Front and rear struts are reinforced on the underside. The strut width is determined by the producer of the stone worktop. The minimum strut width can vary according to the property of the stone.

Type	B	C/D	H	Corner radius Ra/Ri
CookTop V2000 I604 (31179), CookTop V4000 I604 (31115)	≥75 mm	560/490 mm	51.7 mm	5/2 mm
CookTop V4000 I704 (31116)		680/490 mm		
CookTop V4000 I604 (31157)		560/490 mm	52.0 mm	
CookTop V2000 I804 (31182)		750/490 mm	51.7 mm	
CookTop V4000 I804 (31158)			52.0 mm	

- B** Required clearance for ventilation and service replacement over the entire cut-out area.
- E** Steel angle bonded or screw mounted
- F** Side wall
- H** Dimension from the top of the work surface to the underside of the hob (ventilation opening)
- Ra** Outer corner radii of cut-out
- Ri** Corner radii of appliance
- S** Drawer/Cabinet

Flush installation with «DualDesign»



- Corner radii of cut-out, aim for ≤ 5 mm
- Corner radii of appliance 2 mm

CookTop V4000 I904 (31142)

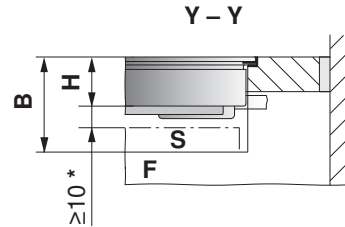
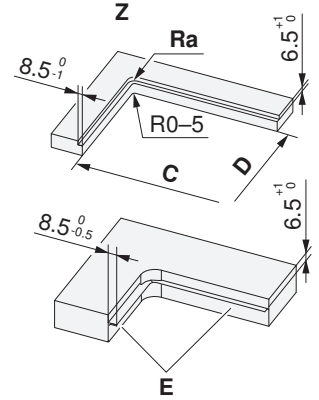
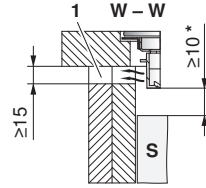
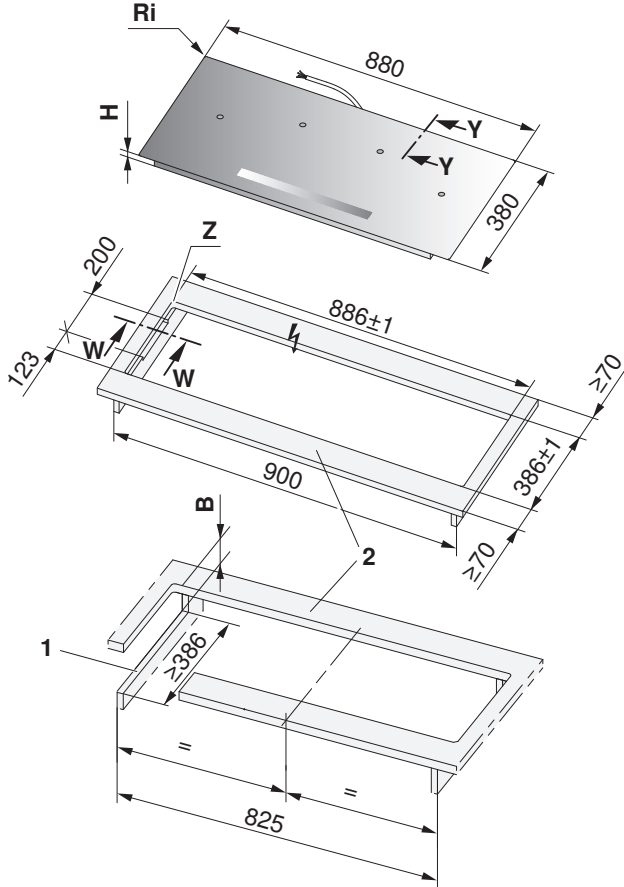

* The required clearance must be observed!

- 1 Mounting cut-outs in side walls left/right for a niche width of ≥ 900 mm, necessary for the ventilation of the appliance.
- 2 Front and rear struts are reinforced on the underside. The strut width is determined by the producer of the stone worktop. The minimum strut width can vary according to the property of the stone.

Type	B	C/D	H	Corner radius Ra/Ri
CookTop V4000	≥ 75 mm	869/369 mm	51 mm	5/2 mm

- B** Required clearance for ventilation and service replacement over the entire cut-out area.
- E** Steel angle bonded or screw mounted
- F** Side wall
- H** Dimension from the top of the work surface to the underside of the hob (ventilation opening)
- Ra** Outer corner radii of cut-out
- Ri** Corner radii of appliance
- S** Drawer/Cabinet

Flush installation with «DualDesign»



- Corner radii of cut-out, aim for ≤5 mm
- Corner radii of appliance 2 mm

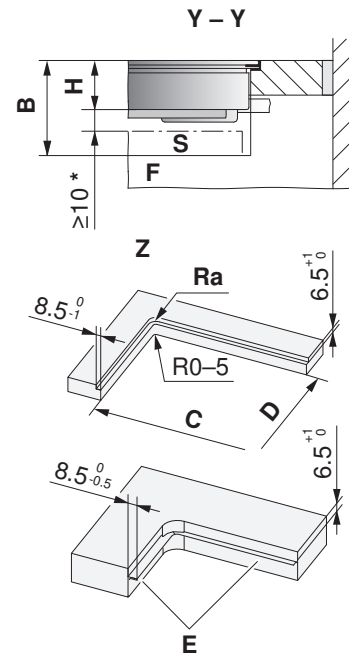
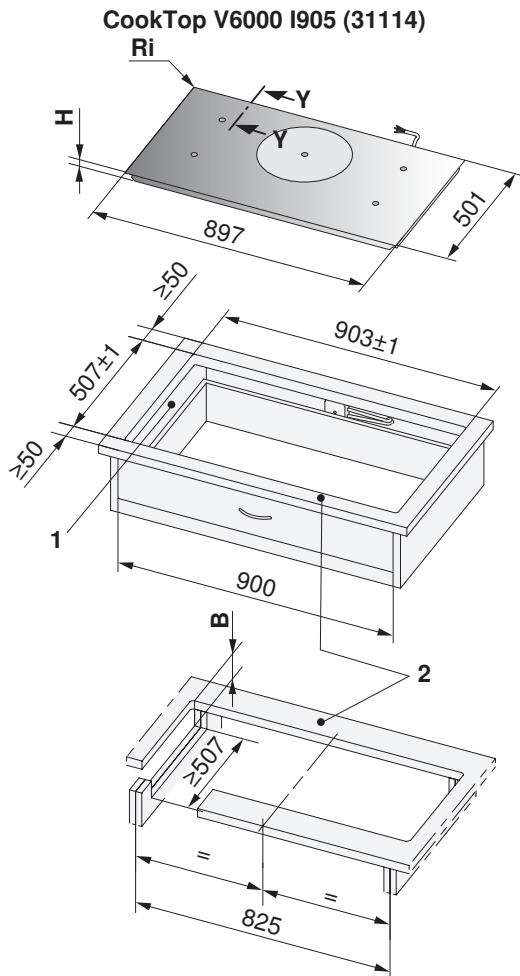

* The required clearance must be observed!

- 1 Mounting cut-outs in side walls left/right for a niche width of ≥900 mm, necessary for the ventilation of the appliance.
- 2 Front and rear struts are reinforced on the underside. The strut width is determined by the producer of the stone worktop. The minimum strut width can vary according to the property of the stone.

Type	B	C/D	H	Corner radius Ra/Ri
CookTop V6000	≥75 mm	886/490 mm	53.3 mm	5/2 mm

- B** Required clearance for ventilation and service replacement over the entire cut-out area.
- E** Steel angle bonded or screw mounted
- F** Side wall
- H** Dimension from the top of the work surface to the underside of the hob (ventilation opening)
- Ra** Outer corner radii of cut-out
- Ri** Corner radii of appliance
- S** Drawer/Cabinet

8.7 Installation without protective plate



Requirements for optimal ventilation (see page 33).

CookTop V4000 I604 (31115)

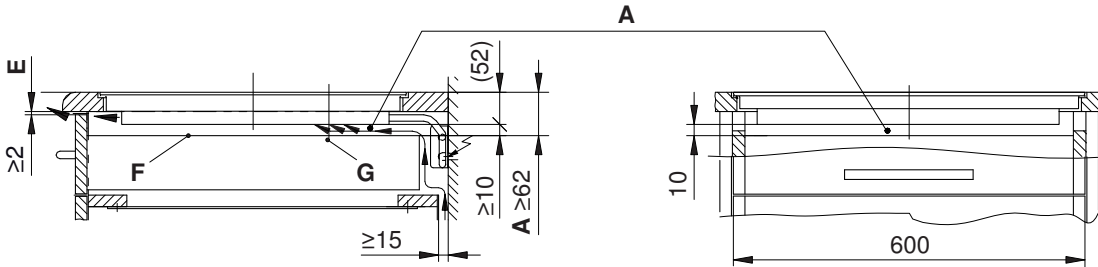

CookTop V4000 I704 (31116), CookTop V4000 I604 (31157), CookTop V4000 I804 (31158)

See diagram above

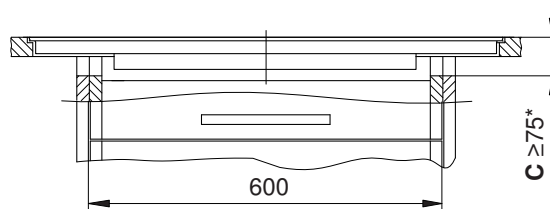

CookTop V6000 I905 (31114)

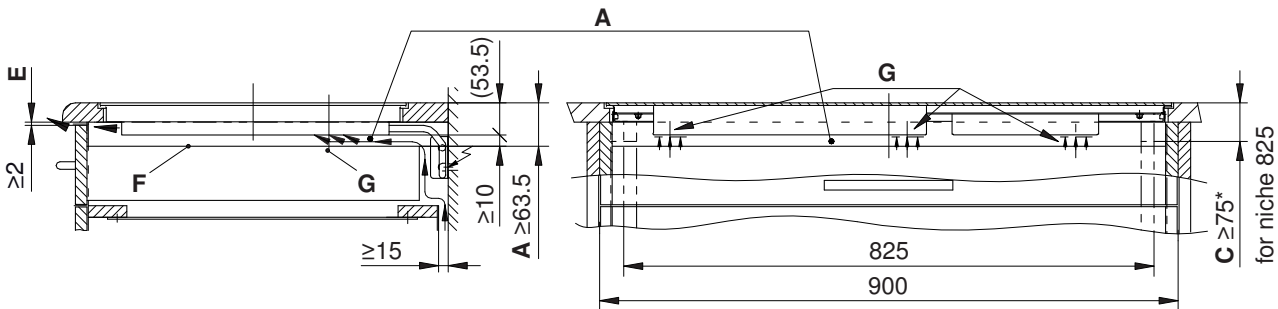

- * Required for flush appliances
- A** Necessary space below the worktop for the ventilation of the appliance
- B** Cut-out in the side walls left/right is necessary for the ventilation of the appliance.
- C** Cut-out in the side walls for disassembly from below, only for flush version
- E** Air gap over entire width of cabinet element
- F** Drawer
- G** Fan

CookTop V4000 I904 (31142)

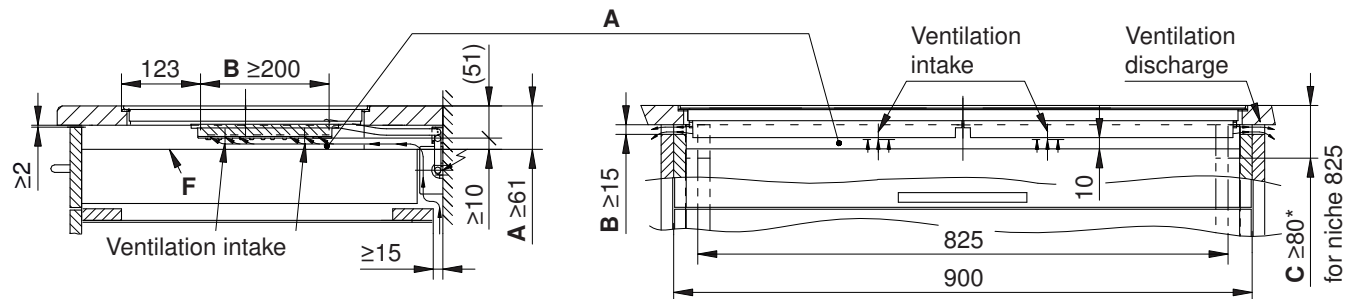

CookTop Teppan Yaki I40 (31140)

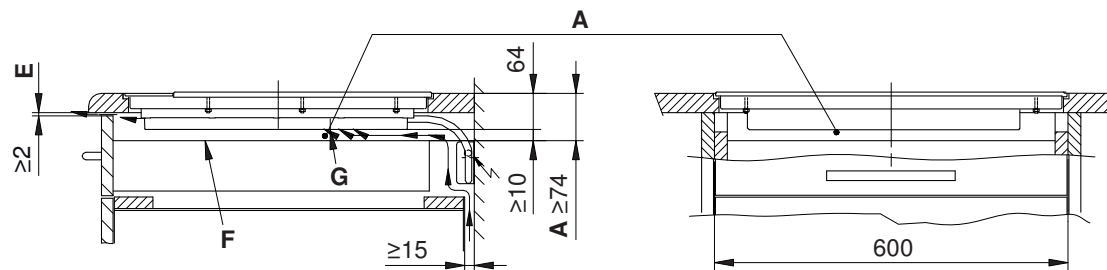

- * Required for flush appliances
- A** Necessary space below the worktop for the ventilation of the appliance
- B** Cut-out in the side walls left/right is necessary for the ventilation of the appliance.
- C** Cut-out in the side walls for disassembly from below, only for flush version
- E** Air gap over entire width of cabinet element
- F** Drawer
- G** Fan

8.8 Installation with protective plate

For more information, see the Accessories (see page 125) section.



Requirements for optimal ventilation (see page 33).

CookTop V4000 I604 (31115)

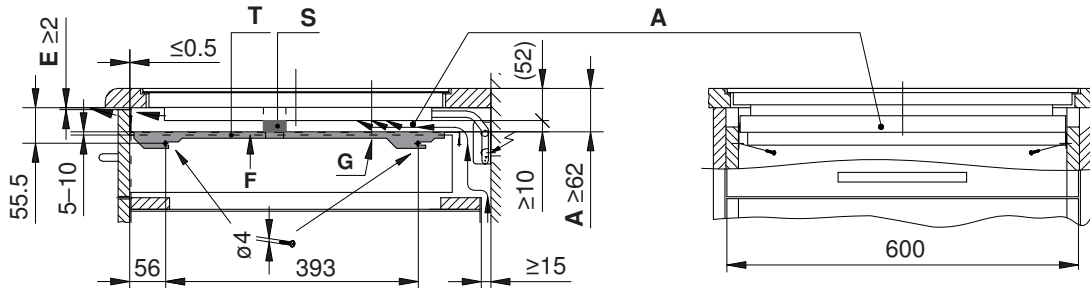

CookTop V4000 I704 (31116), CookTop V4000 I604/I804 (31157/31158)

See diagram above

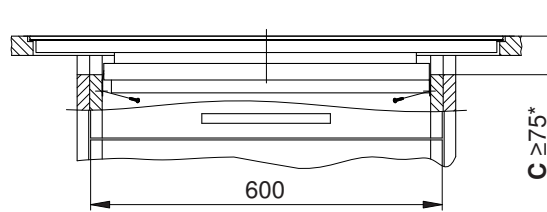

CookTop V6000 I905 (31114)

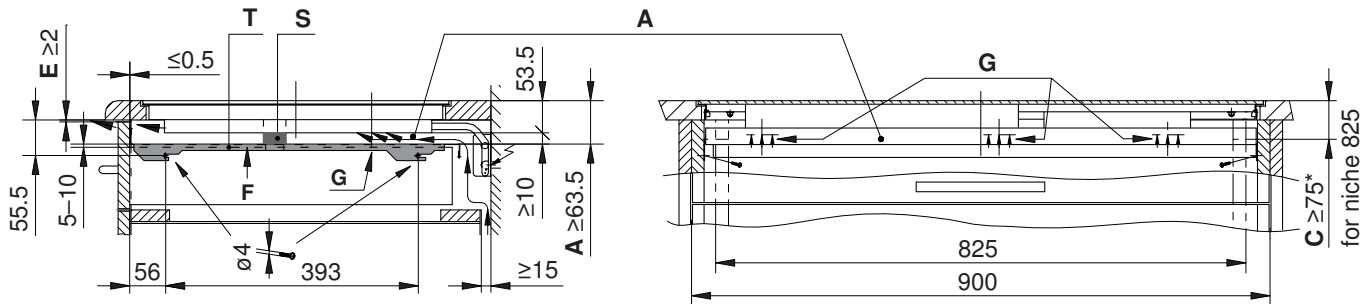

* Required for flush appliances

- A** Necessary space below the worktop for the ventilation of the appliance
- B** Cut-out in the side walls left/right is necessary for the ventilation of the appliance.
- C** Cut-out in the side walls for disassembly from below, only for flush version
- E** Air gap over entire width of cabinet element
- F** Drawer
- G** Fan
- S** Well-fitting seal over width of cabinet element
- T** Ventilation protective plate

CookTop V4000 I904 (31142)

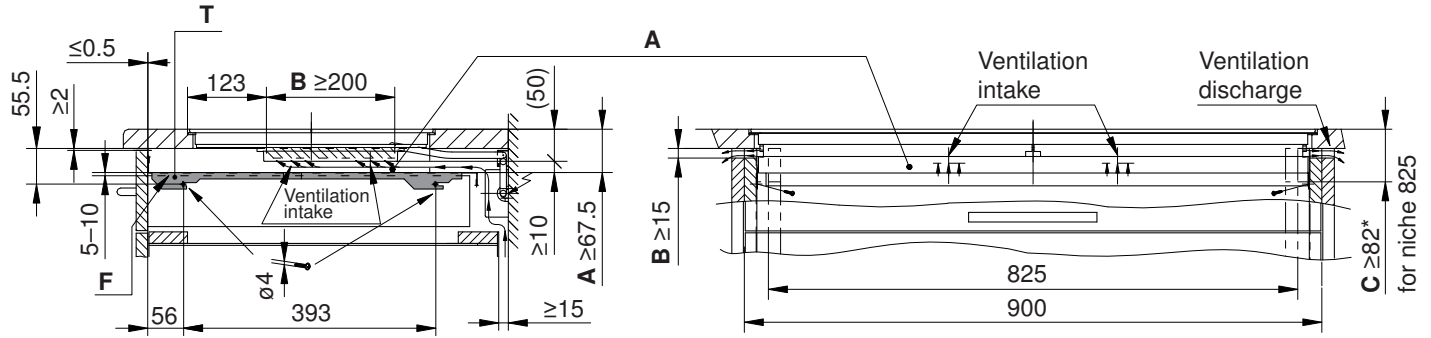

CookTop Teppan Yaki I40 (31140)

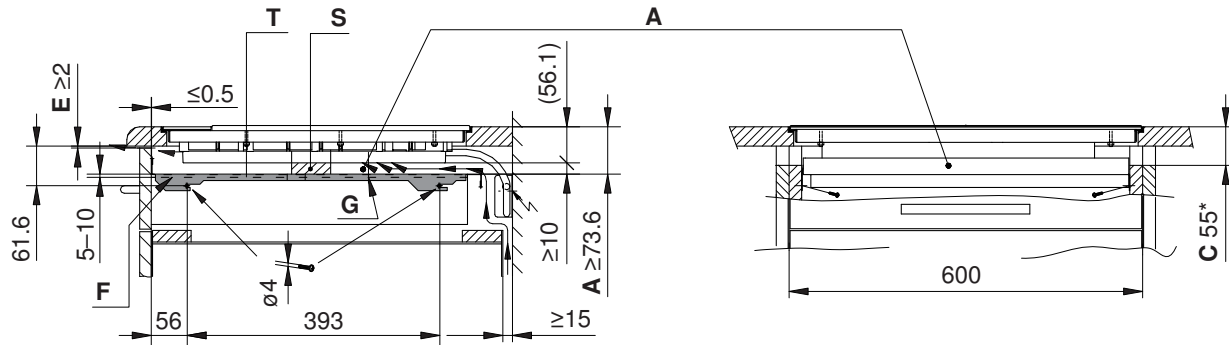

- * Required for flush appliances
- A** Necessary space below the worktop for the ventilation of the appliance
- B** Cut-out in the side walls left/right is necessary for the ventilation of the appliance.
- C** Cut-out in the side walls for disassembly from below, only for flush version
- E** Air gap over entire width of cabinet element
- F** Drawer
- G** Fan
- S** Well-fitting seal over width of cabinet element
- T** Ventilation protective plate

CookTop V6000 I906 FullFlex (31134)



The installation of a ventilation protection plate with seal is strongly recommended.

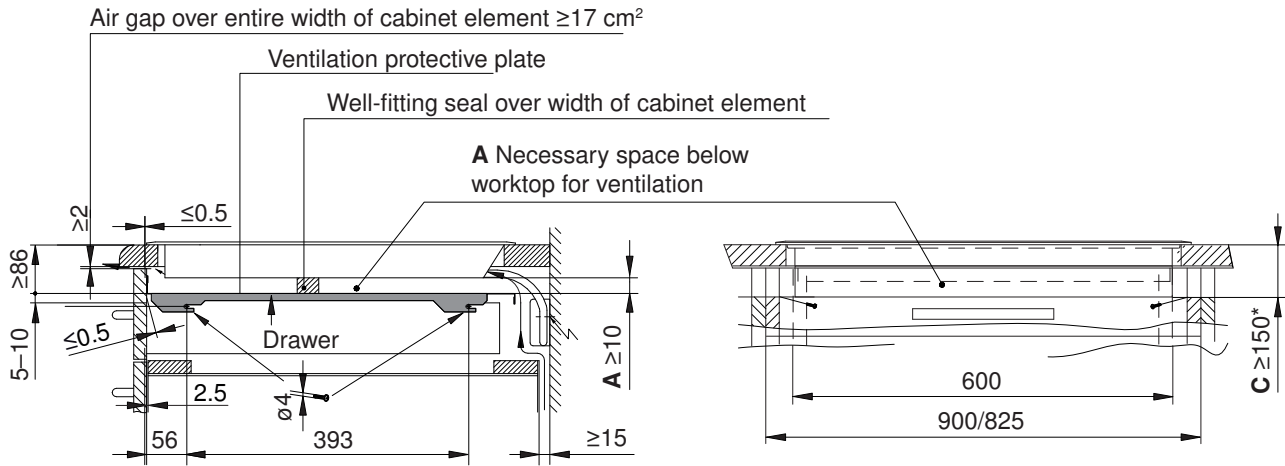

CookTop V6000 I705 FullFlex (31132)



The installation of a ventilation protection plate with seal is strongly recommended.

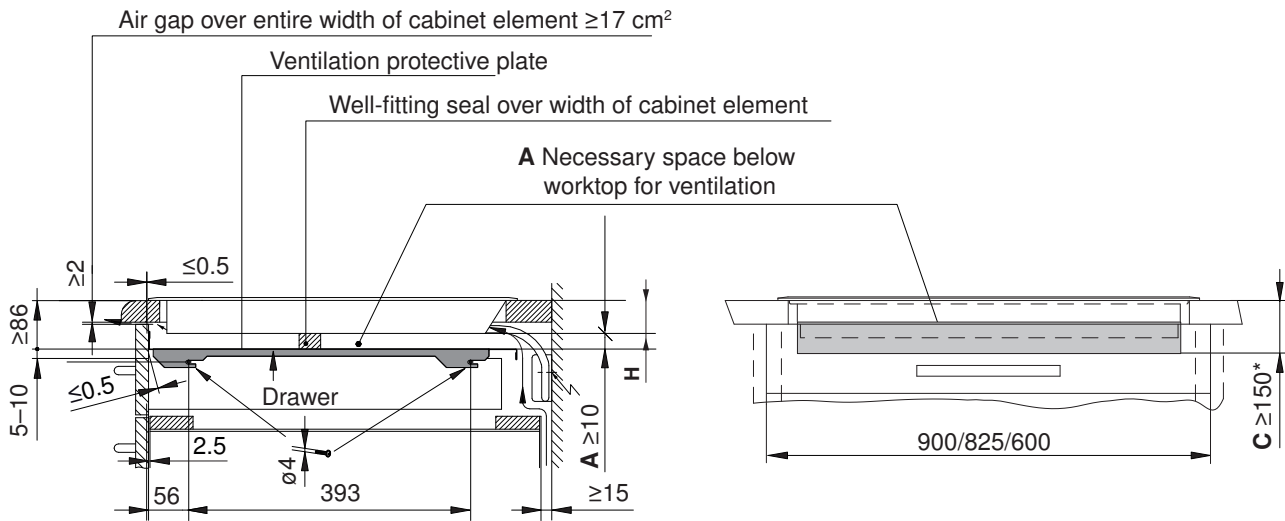

- * Required for flush appliances
- A** Necessary space below the worktop for the ventilation of the appliance
- B** Cut-out in the side walls left/right is necessary for the ventilation of the appliance.
- C** Cut-out in the side walls for disassembly from below, only for flush version
- E** Air gap over entire width of cabinet element
- F** Drawer
- G** Fan
- S** Well-fitting seal over width of cabinet element
- T** Ventilation protective plate



9 Gas hobs



The distance from the appliance cut-out to the back wall must be ≥ 50 mm and to the side walls ≥ 200 mm. Parts such as side walls and reinforcing strips which protrude into the installation space under the cooking zone must be made of fire-resistant material.

The distance between the underside of the appliance tray and any part of the cabinet beneath that is made of combustible material must be ≥ 20 mm.

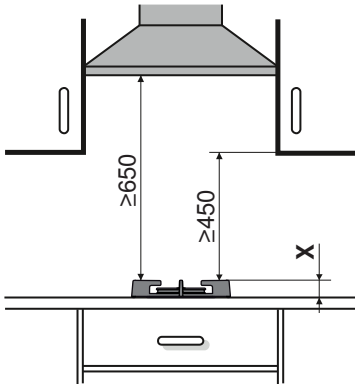

When a range hood is installed above the gas hob, the minimum distance given for the particular range hood must be observed.

Furthermore, the minimum distances illustrated must be strictly complied with even if a lower value is stated for the range hood.

A gas hob cannot be built in directly over another appliance due to the installation depth and the gas connection.

Model number	Type	X
31063	GAS411GSBZ	73.1
31072	GAS951GSBZ	
31075	GAS731GKBZ	
31064	GAS421GSBZ	46.7
31071	GAS641GSBZ	

9.1 Electrical connection data



General information on the electrical connections and an overview of the positions can be found in section Overview of connections, ranges and dimensions (see page 5).

Appliance	Mains connection	Fuse	Rated load	Mains cable
GAS411GSBZ, GAS421GSBZ, GAS641GSBZ, GAS731GKBZ, GAS951GSBZ	220–240 V~50–60 Hz	≥ 3 A	<20 W	1.7 m, with plug

9.2 Gas connection

The gas connection and the conversion to another gas type must be carried out by an authorized installer.

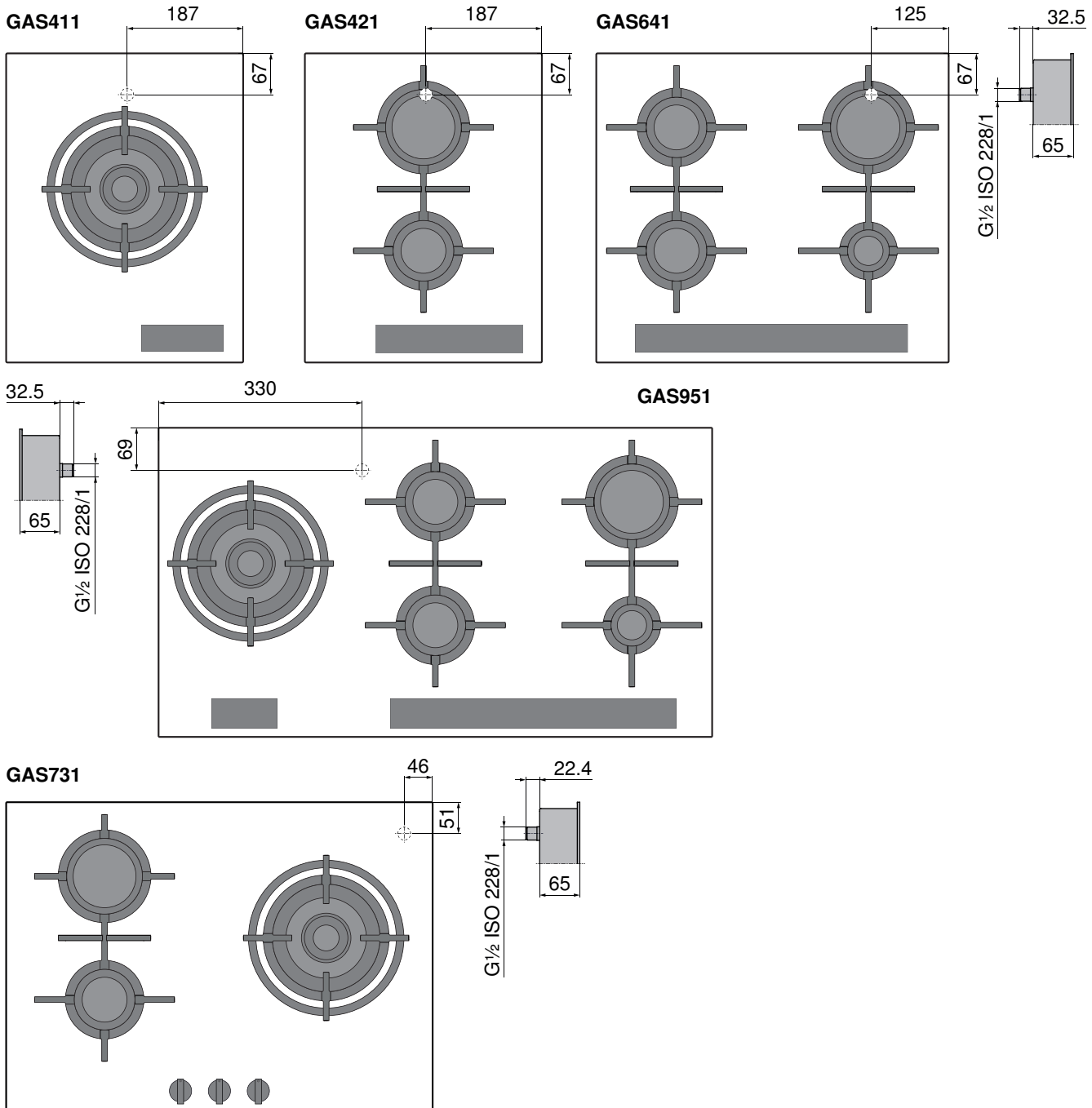

- ▶ The gas connection must be positioned so that the stopcock and the supply connection point are accessible with the appliance installed.
- ▶ The gas connection must be positioned so that it does not get detrimentally hot during operation. In particular, the gas hose assemblies and the appliance's connection fittings must be clear of hot exhaust gases (e.g. from an oven).
- ▶ It must be ensured that the gas hose and the mains connection do not touch any hot parts of the appliance, otherwise the gas hose and the mains cable could become damaged through heat.
- ▶ A flexible connection lead (max. length 1.5 m) must be positioned so that it runs freely and does not come into contact with any movable parts of the kitchen cabinets (e.g. a drawer).

1/2-inch metric thread

The gas connection on the appliance has a 1/2-inch external thread in accordance with ISO 228/1. If the gas installation on site already has a corresponding counterpart, the gas appliance can be directly connected to it.



1/2-inch conical thread

If the gas connection has a conical thread, the connection piece and sealing ring must first be screwed onto the appliance. The connection piece has a conical external thread R 1/2-inch in accordance with ISO 7/11. In the case of a conical screw connection, the thread makes the seal, which is why the thread must be sealed with hemp or Teflon tape.



9.3 Ventilation

In order to guarantee minimum ventilation, a space of ≥ 20 mm height is necessary beneath the appliance.

- A** The rear panel of the base unit must be open around the work surface cut-out to guarantee continuous air circulation through the ventilation slits. The air must be drawn in from outside the cabinet and be able to circulate freely from inside the cabinet to the hob. The lower plinth must not be hermetically sealed. This can be achieved through a shadow gap at the plinth panel or the use of a ventilation grille.
- B** Alternatively, a concealed fresh air supply can ensure air circulation inside the cabinet. In order that enough cold air can be drawn in, there must be a continuous circulation of fresh air that extends outside the cabinet. The air must be drawn in from outside the cabinet and be able to circulate freely from inside the cabinet to the hob. The lower drawer panel should therefore not hermetically seal the cabinet.

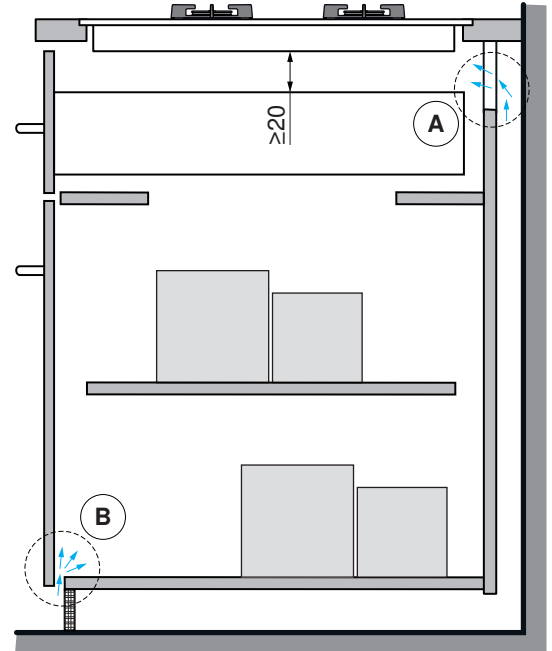

9.4 Setting up appliance to use local gas type



The appliance settings must match the local gas type and connection pressure. If the gas type and connection pressure have not been preset, the appliance has to be converted using the nozzle set supplied or other nozzle sets available as accessories. Information on the default gas setting as well as on the supplied and optional nozzle sets by country can be found in the catalogue. Conversion to another gas type is described in detail in the relevant installation instructions.

Overview of nozzle sets

Type	Default gas setting	Nozzle set (supplied)	Additional nozzle sets available for country-specific combinations of gas type and connection pressure
GAS411GSBZ	Natural gas AU (G20), 1.0 kPa	Universal liquid gas (G30/G31), 2.75 kPa	No other nozzle sets are permitted
GAS421GSBZ			
GAS641GSBZ			
GAS731GKBZ			
GAS951GSBZ			

* Validity with model no.

10 Combined hob installation

10.1 Surface-mounted combination

The surface-mounted hob combination is currently only possible for electric hobs (up to max. hob size 40), gas hobs and hob hoods. The intermediate support 1014361 (stainless steel) or 1019199 (black) is required for this.



Dimensions table for hobs

Combinations	Cut-out width C	Intermediate support position G1	Intermediate support position G2
40+40 cm	760 mm	380 mm	-
40+60 cm	947 mm	380 mm	-
40+70 cm	1067 mm	380 mm	-
40+40+40 cm	1147 mm	380 mm	767 mm
40+90 cm	1273 mm	380 mm	-
40+40+60 cm	1334 mm	380 mm	767 mm

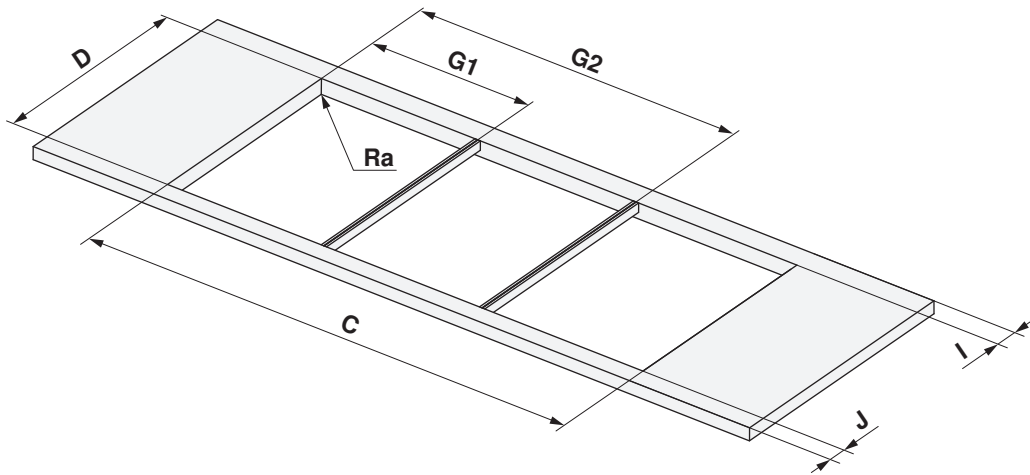
D 490 mm
I ≥50 mm
J ≥50 mm
Ra 0–5 mm

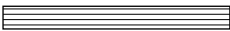

10.2 Examples of surface-mounted combinations

		
Worktop	Hobs	Intermediate support

Double surface-mounted combination

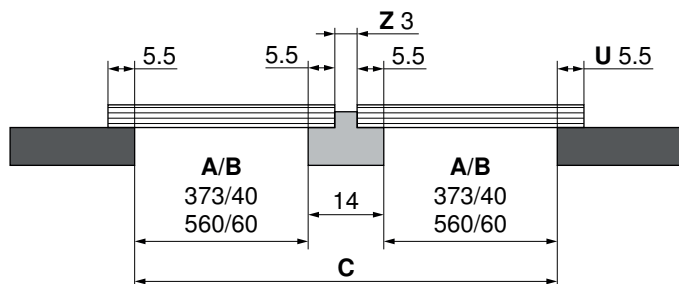

Example for cut-out width **C** with 40+40 cm: $373+14+373 = 760$ mm

Triple surface-mounted combination

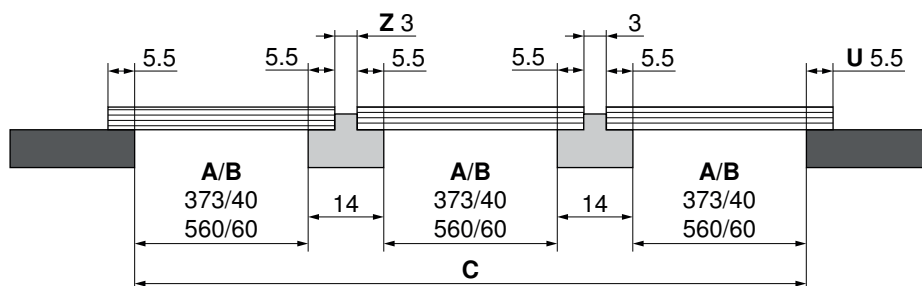

Example for cut-out width **C** with 40+40+40 cm: $373+14+373+14+373 = 1147$ mm

A	B	C	U	Z
Cut-out in mm	Hob size in cm	Cut-out width	Hob/worktop overlap	Intermediate support

10.3 Flush combination

The flush-mounted hob combination is currently possible for all gas hobs, hob hoods and flush-mounted electric hobs with a base plate depth of 501 mm. The intermediate support kit H63789 (contains two intermediate supports) is required.

Dimensions table for hobs

Combinations	Cut-out width E	Cut-out width C	Intermediate support position G1	Intermediate support position G2
40+40 cm	777 mm	760 mm	388.5 mm	-
40+60 cm	964 mm	947 mm	388.5 mm	-
40+70 cm	1084 mm	1067 mm	388.5 mm	-
40+40+40 cm	1164 mm	1147 mm	388.5 mm	775.5 mm
40+90 cm	1290 mm	1273 mm	388.5 mm	-
40+40+60 cm	1351 mm	1334 mm	385.5 mm	775.5 mm

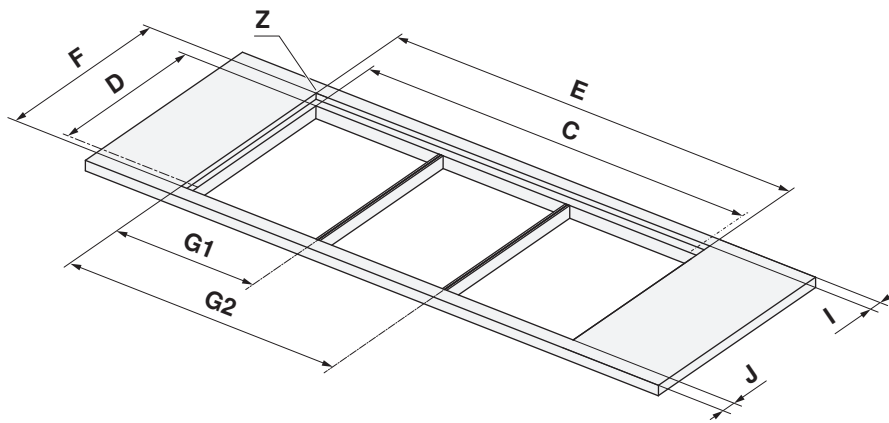

- I ≥41.5 mm
- J ≥41.5 mm
- D 490±1 mm
- F 507±1 mm
- Ra 5 mm

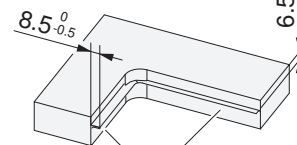
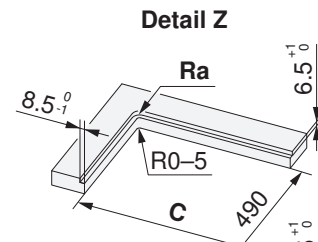
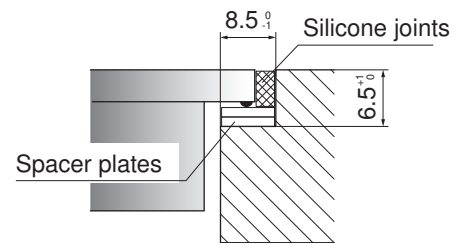

Steel angle bonded or screw mounted

10.4 Examples of flush combinations

Worktop	Hobs	Intermediate support	Silicone joint

Double flush combination

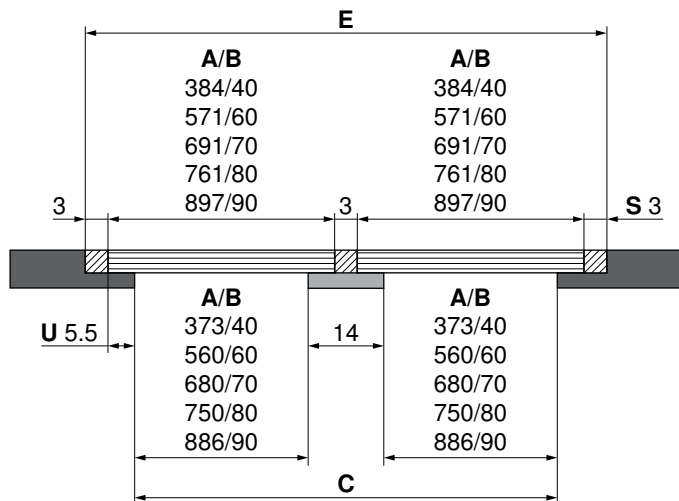

Example for cut-out width **E** with 40+40 cm: $3+384+3+384+3 = 777$ mm

Example for cut-out width **C** with 40+40 cm: $373+14+373 = 760$ mm

Triple flush combination

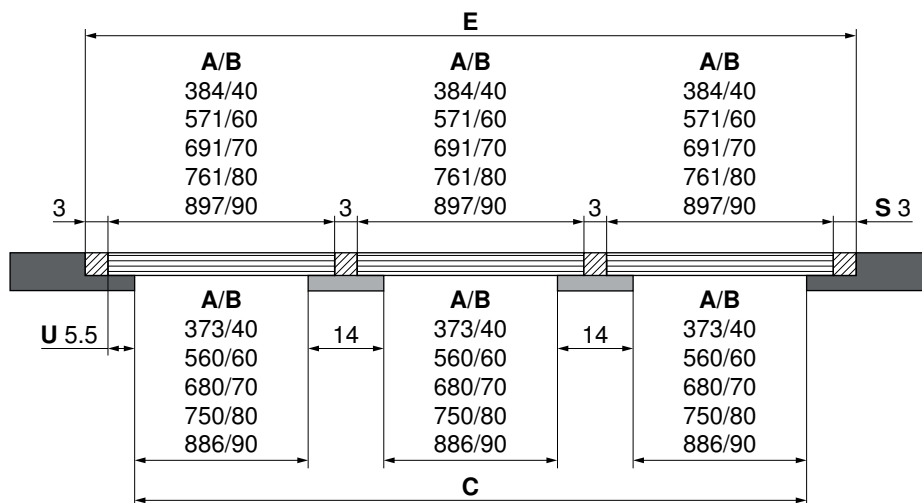

Example for cut-out width **E** with 40+40+40 cm: $3+384+3+384+3+384+3 = 1164$ mm

Example for cut-out width **C** with 40+40+40 cm: $373+14+373+14+373 = 1147$ mm

A	B	C/E	S	U
Cut-out in mm	Hob size in cm	Cut-out width	Silicone joint	Hob/worktop overlap

11 CombiCookTop induction hob with hood

11.1 Electrical connection data



General information on the electrical connections and an overview of the positions can be found in section Overview of connections, ranges and dimensions (see page 5).

Type	Mains connection	Fuse	Rated load	Mains cable
CombiCookTop V2000/V4000	220–240 V~ 50–60 Hz	32 A	7400 W	1.7 m, without plug

11.2 Dimensions



All plastering, plasterboarding, wall papering and painting work is to be carried out prior to installing the appliance. Ensure that the material is sufficiently stable. For the recirculation mode, ensure sufficient ventilation so that moisture can escape. Plan in suitable material/wood.

CombiCookTop V2000 I604 (31175/31176)

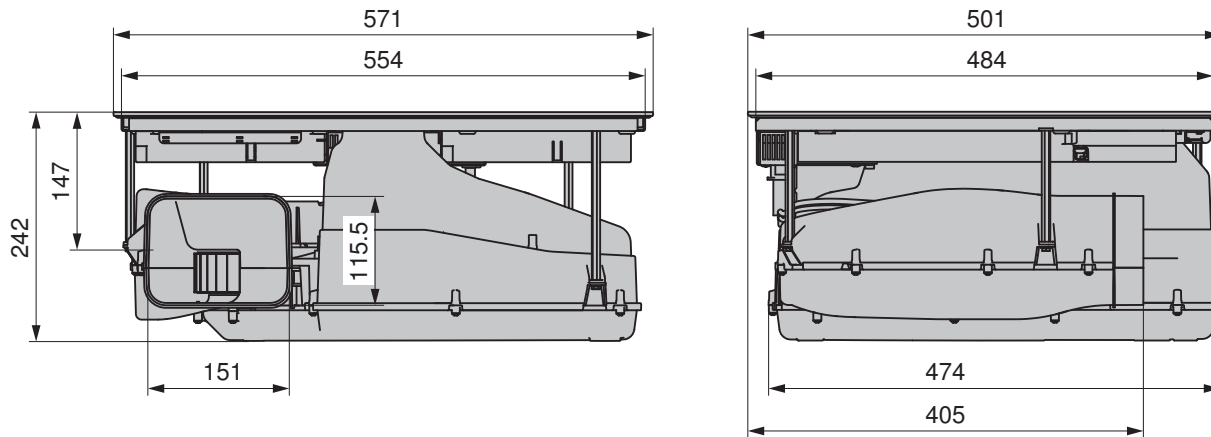

Installation for recirculation operation, unguided

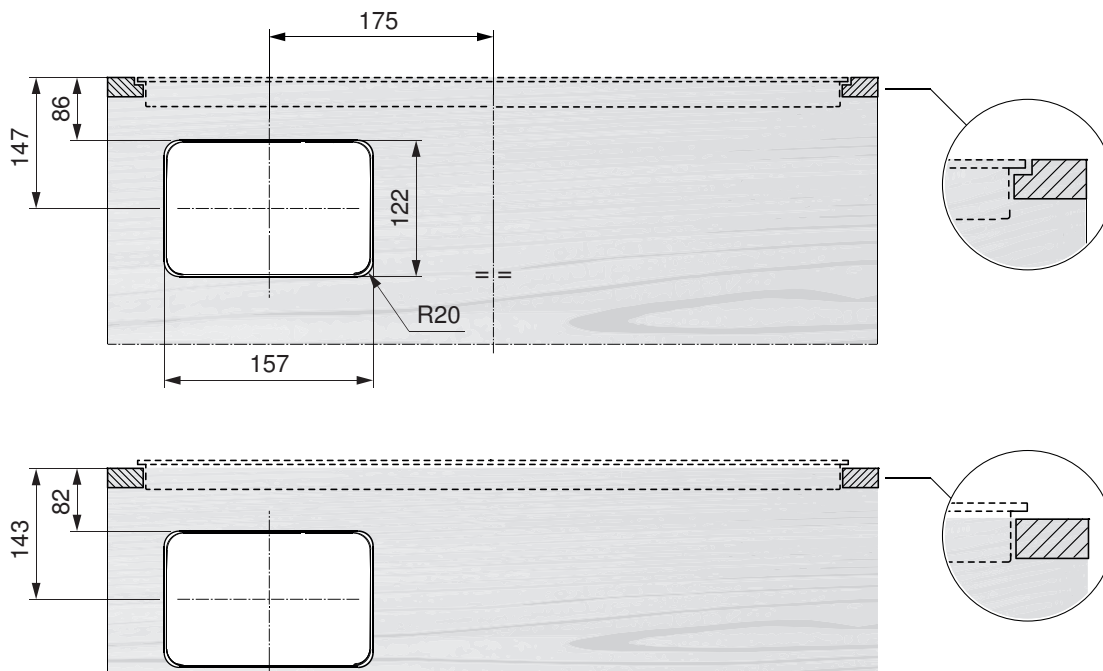

CombiCookTop V2000 I804 (31095), CombiCookTop V4000 I804 (31096)

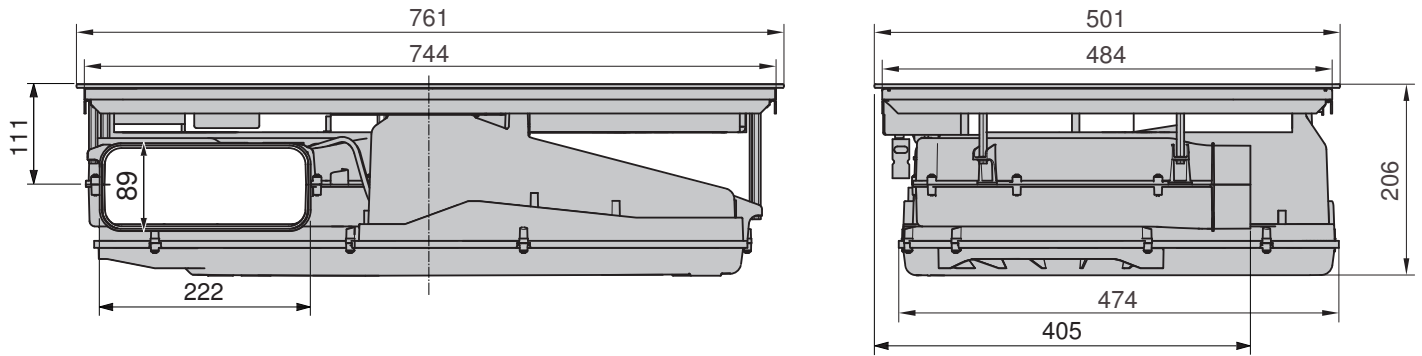

Installation for recirculation operation, unguided

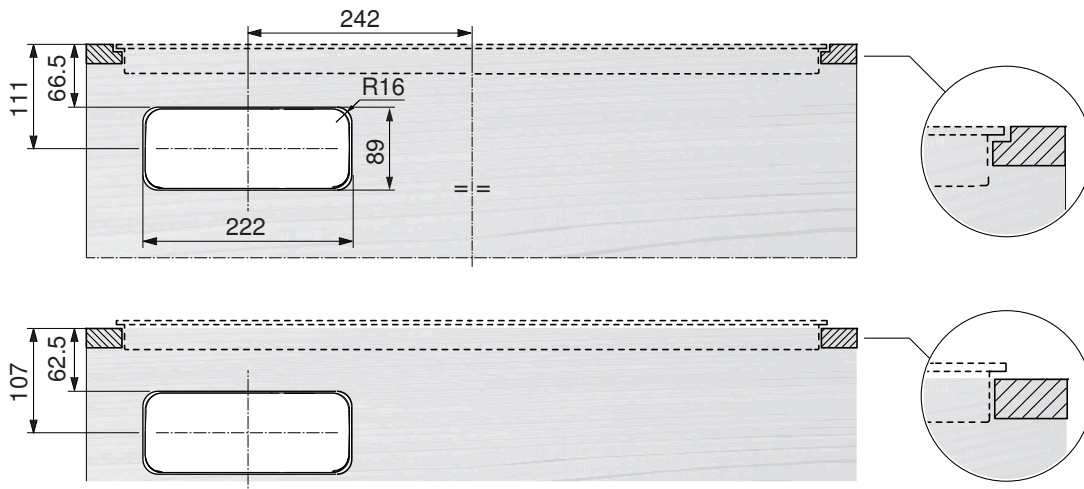

11.3 Scope of delivery

CombiCookTop V2000 I804, CombiCookTop V4000 I804

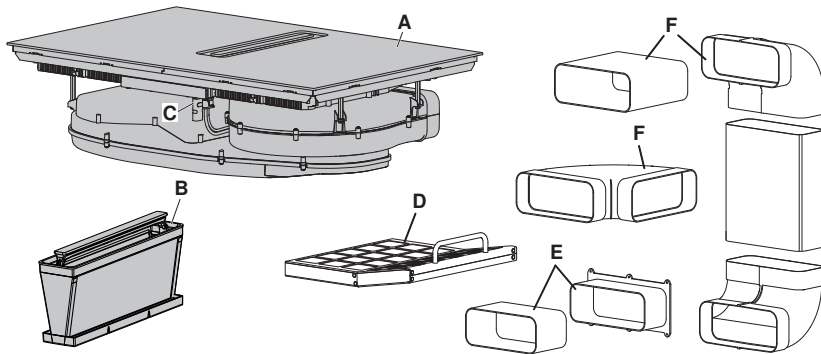

- A Hob
- B Filter cassette with grease filter
- C Potential-free switch contact (window contact switch)

Not included in the scope of delivery, but available for order as accessories:

- D Activated charcoal filter (recirculation operation only)
- E Telescopic connection for recirculation operation, unguided
- F Flat channels, elbow variants and transition pieces

CombiCookTop V2000 I604

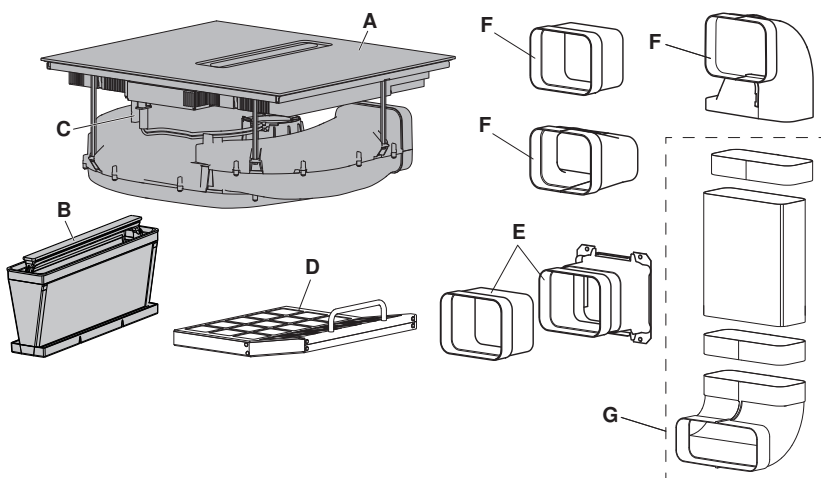

- A Hob
- B Filter cassette with grease filter
- C Potential-free switch contact (window contact switch)

Not included in the scope of delivery, but available for order as accessories:

- D Activated charcoal filter (recirculation operation only)
- E Telescopic connection for recirculation operation, unguided
- F Special duct, straight adapter and special 90° elbow
- G Flat channels, universal connectors and elbows

11.4 Ventilation of the hob

For installation of hobs with integrated range hood, the following minimum requirements apply:

1. The hot air exhaust should be provided by a ventilation slit of $\geq 2 \text{ mm}$ at the front.
2. Not only exhaust air but also replacement air in the cabinet should be taken into account. There are different ways to do this, including:
 - a) The rear panel of the base unit must be open around the work surface cut-out to guarantee continuous air circulation through the ventilation slits. The air must be drawn in from outside the cabinet and be able to circulate freely from inside the cabinet to the hob. The lower plinth must not be hermetically sealed. This can be achieved through a shadow gap at the plinth panel or through the use of a ventilation grille.
 - b) Alternatively, a concealed fresh air supply can ensure air circulation inside the cabinet. In order that enough cold air can be drawn in, there must be a continuous circulation of fresh air that extends outside the cabinet. The lower drawer panel should therefore not hermetically seal the cabinet.

Extraction or recirculation operation with flat channel system

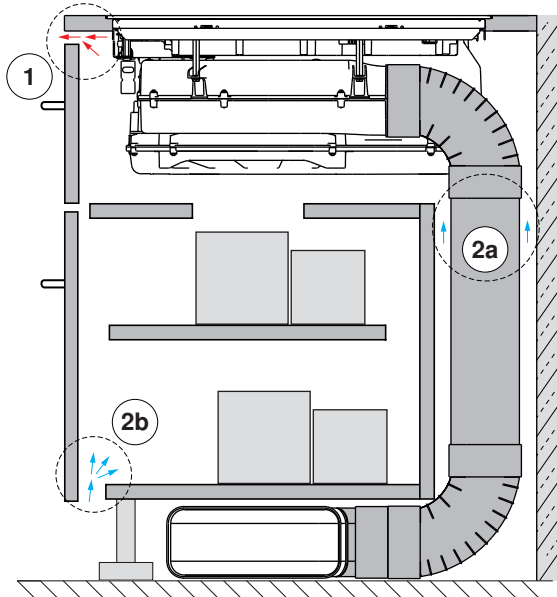

Recirculation operation without flat channel system

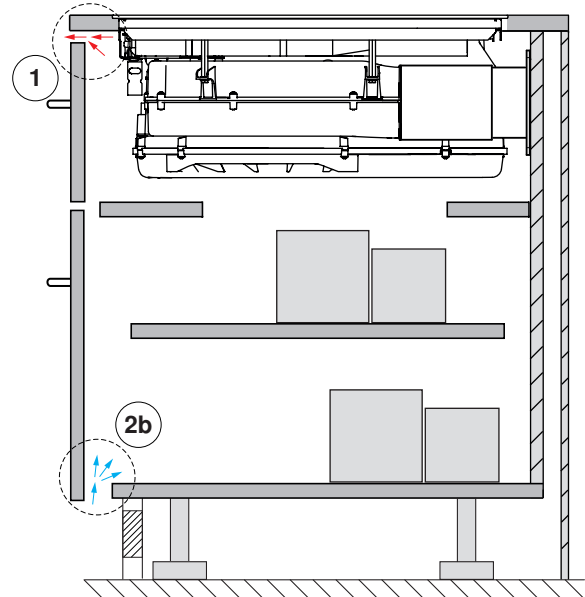

For recirculation operation without flat channel system, the exhaust air from the range hood and the ventilation (supply air for hob) must not mix in this installation variant. These areas must be kept separate (see supply air option 2b above)!

Inadequate ventilation will affect the performance of the appliance. Ventilation slit should extend across the entire width where possible.

11.5 Surface-mounted installation

The layout of the hob to be fitted may differ from the hob illustrated!

CombiCookTop V2000 I604 (31175/31176)

**CombiCookTop V2000 I804 (31095),
 CombiCookTop V4000 I804 (31096)**

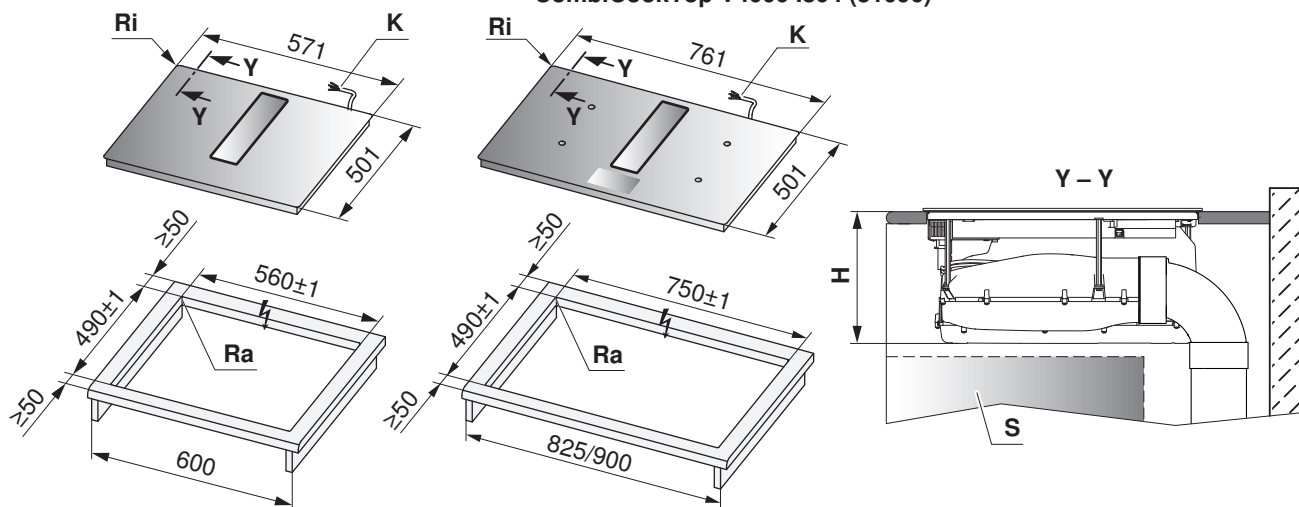

Model designation	H	Corner radius Ra/Ri
CombiCookTop V2000 I604	238 mm	5/2 mm
CombiCookTop V2000 I804, CombiCookTop V4000 I804	202 mm	

- H** Dimension from the top of the work surface to the underside of the hob
- S** Drawer
- K** Cable length 170 cm
- Ri** Corner radii of appliance
- Ra** Outer corner radii of cut-out



Ensure access from below for service and maintenance work across the entire width of the cabinet. Where an intermediate base is to be provided between the drawer and the appliance, it must be removable from below.

Installation

- ▶ Create an accurate installation cut-out.
- ▶ Carefully put the appliance in the installation cut-out and press against the worktop with sufficient overlap.



Access to the appliance from below via the entire cut-out area must be guaranteed. For servicing purposes, the induction generator can be removed from below with the mounting plate. It must be possible to unscrew the contact-proof covers from below.



11.6 Flush installation

The layout of the hob to be fitted may differ from the hob illustrated!

CombiCookTop V2000 I604 (31175/31176) CombiCookTop V2000 I804 (31095),
 CombiCookTop V4000 I804 (31096)

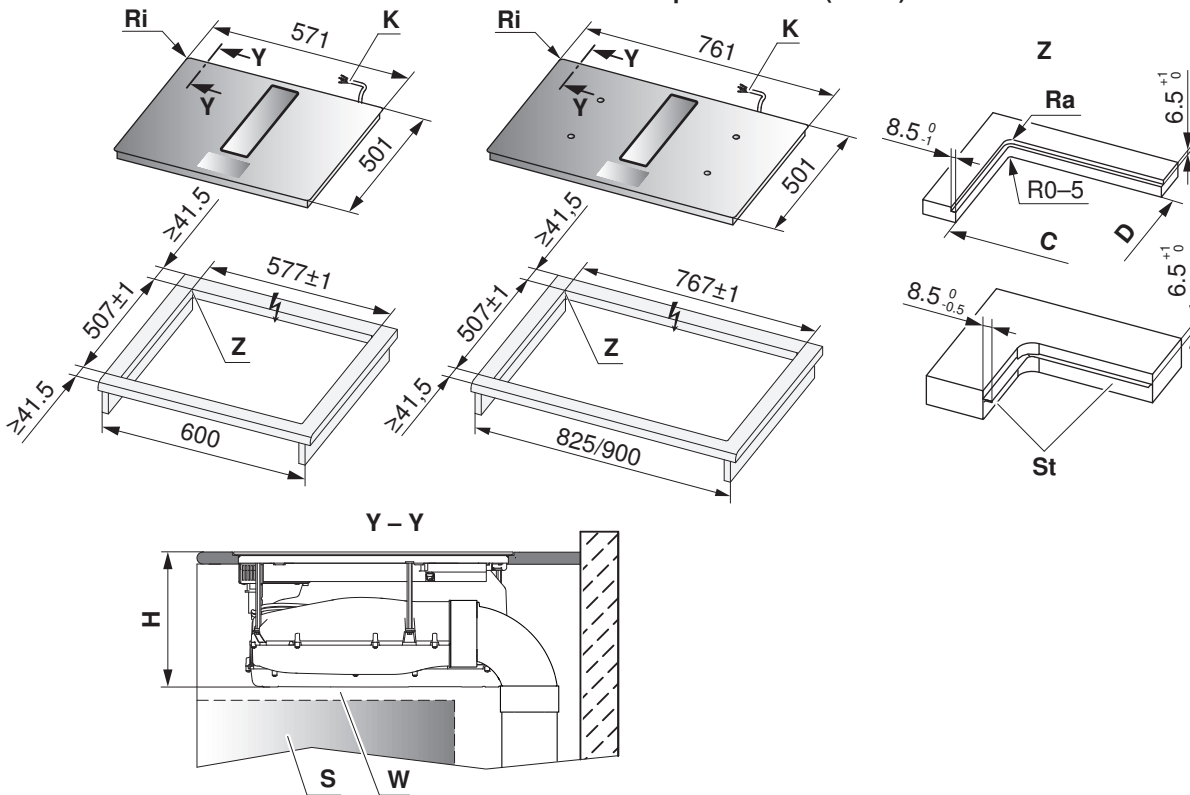

Model designation	C/D	H	Corner radius Ra/Ri
CombiCookTop V2000 I604	560/490	242 mm	5/2 mm
CombiCookTop V2000 I804, CombiCookTop V4000 I804	750/490	206 mm	

- H** Dimension from the top of the work surface to the underside of the hob
- St** Steel angle bonded or screw mounted
- S** Drawer
- W** Side panel
- K** Cable length 170 cm
- Ri** Corner radii of appliance
- Ra** Outer corner radii of cut-out

Ensure access from below for service and maintenance work across the entire width of the cabinet. Where an intermediate base is to be provided between the drawer and the appliance, it must be removable from below.

Installation

- ▶ Create an accurate installation cut-out.
 - The mounting surface can be reamed out or created by installing wood/stone supports or using the steel angle set (see Accessories).

Access to the appliance from below via the entire cut-out area must be guaranteed. For servicing purposes, the induction generator can be removed from below with the mounting plate. It must be possible to unscrew the contact-proof covers from below.

- ▶ Prepare the cut-out and appliance in accordance with the specifications in the enclosed cementing-in instructions.
- ▶ Carefully cement the appliance in and leave the silicone sealant to dry for at least 24 hours.
- ▶ Connect to the electrical mains connection before inserting the appliance, if necessary.

11.7 Installation overview for base



Observe local regulations on pipework RF1 (metal) and RF3 (plastic)!

CombiCookTop V2000 I604 (31175/31176)

Dimensions in brackets are for installation of a hob with dials (available as an option).

Recirculation operation, unguided, with telescopic connection E

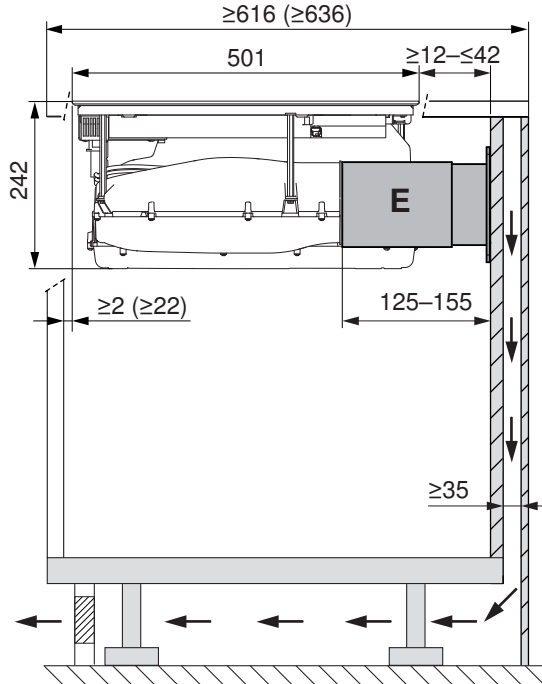

Recirculation operation, unguided, long

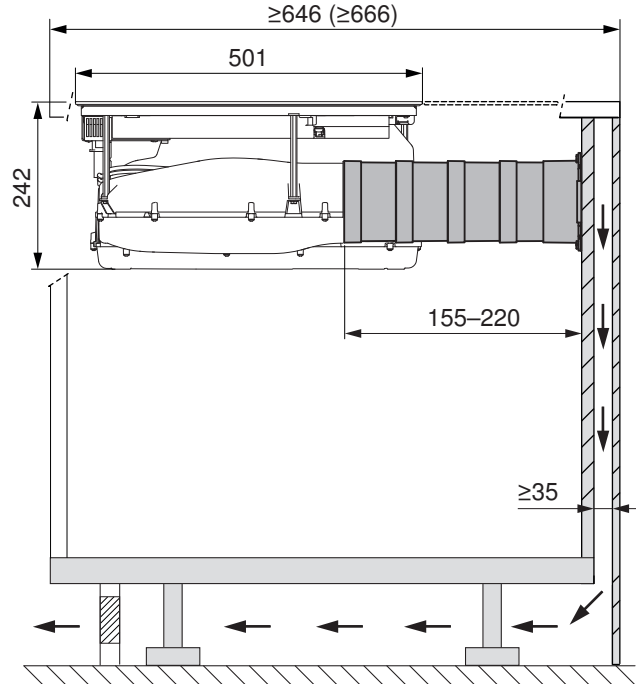

Extraction or recirculation operation with flat channel system

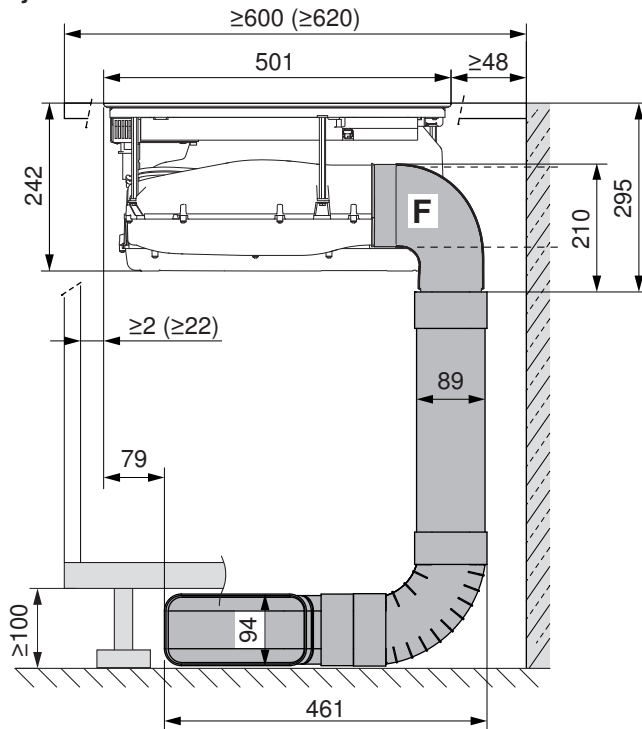

Extraction or recirculation operation with flat channel system, extra deep

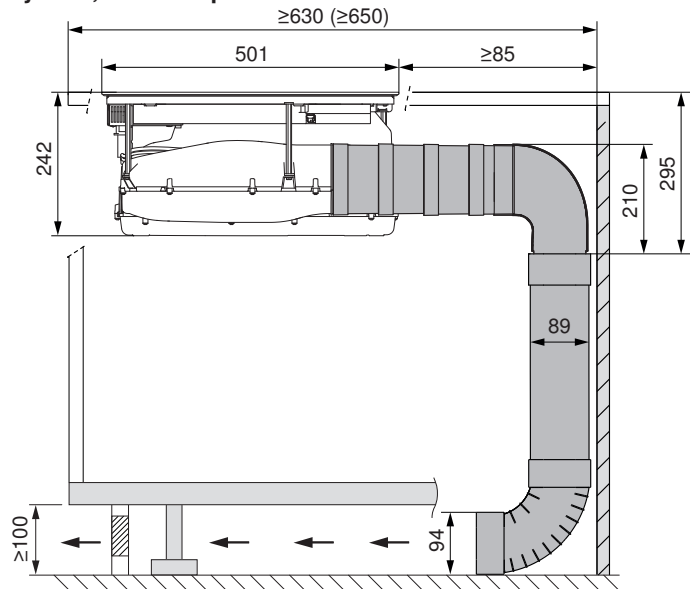

CombiCookTop V2000 I804 (31095), CombiCookTop V4000 I804 (31096)

Recirculation operation, unguided, with telescopic connection (E*)

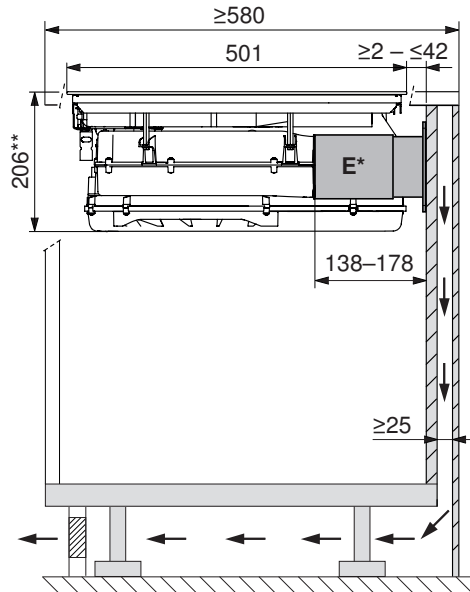

Recirculation operation, unguided, long

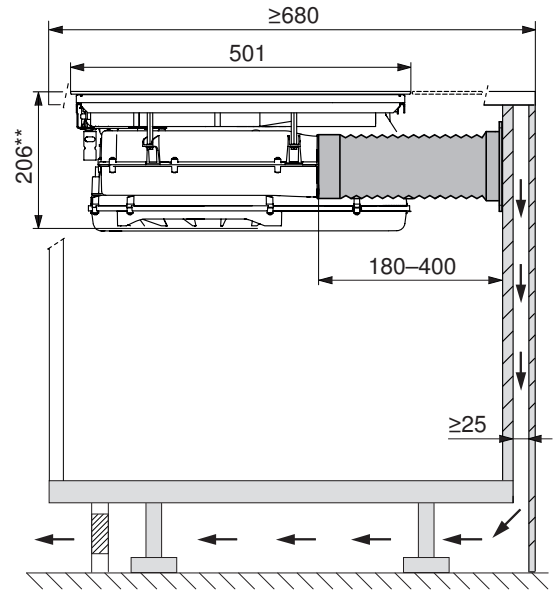

Extraction or recirculation operation with flat channel system, plastic

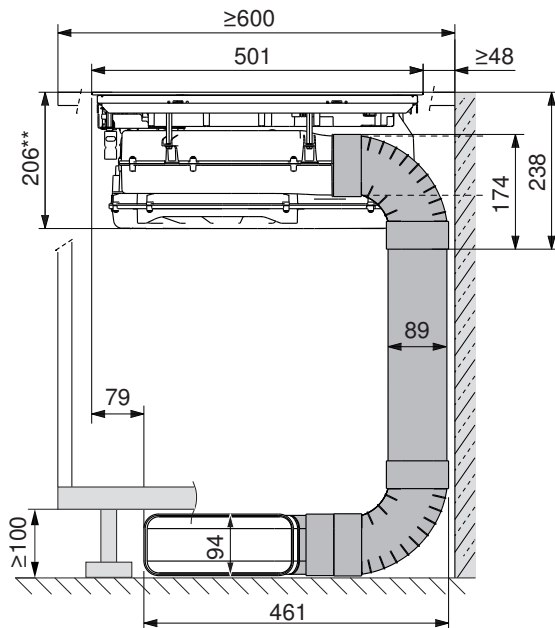

Extraction operation with flat channel system, metal

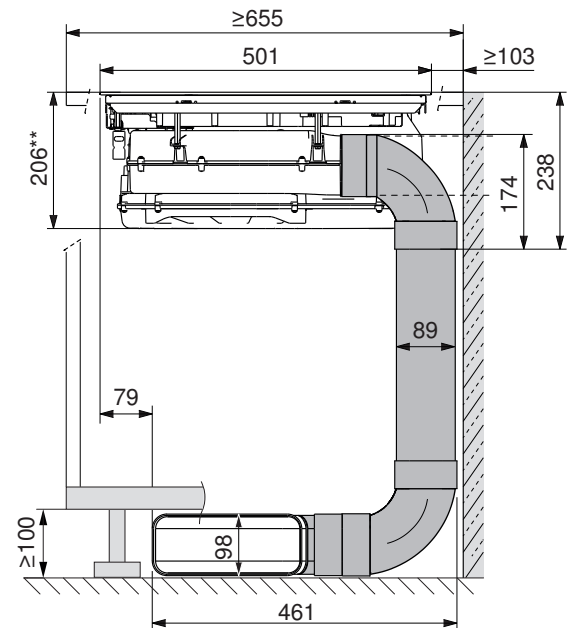

** = Flush installation (surface-mounted installation: 202 mm)

Extraction or recirculation operation with flat channel system, extra deep

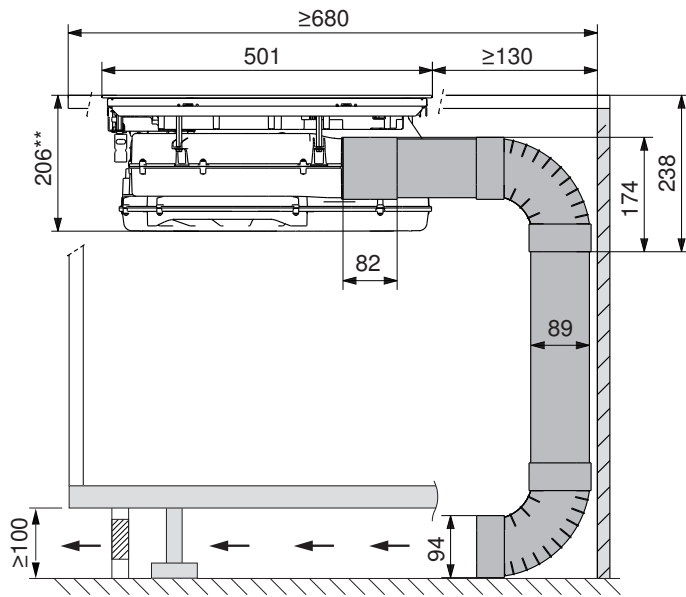

** = Flush installation (surface-mounted installation: 202 mm)



Flat channels, elbow variants and transition pieces are not included in the scope of delivery, but are available for order as accessories. The individual components required must be taken into account during planning.

11.8 Flat channel systems made of plastic (PRIME) for the CombiCookTop I604



Plastic accessories are not made of fireproof material.

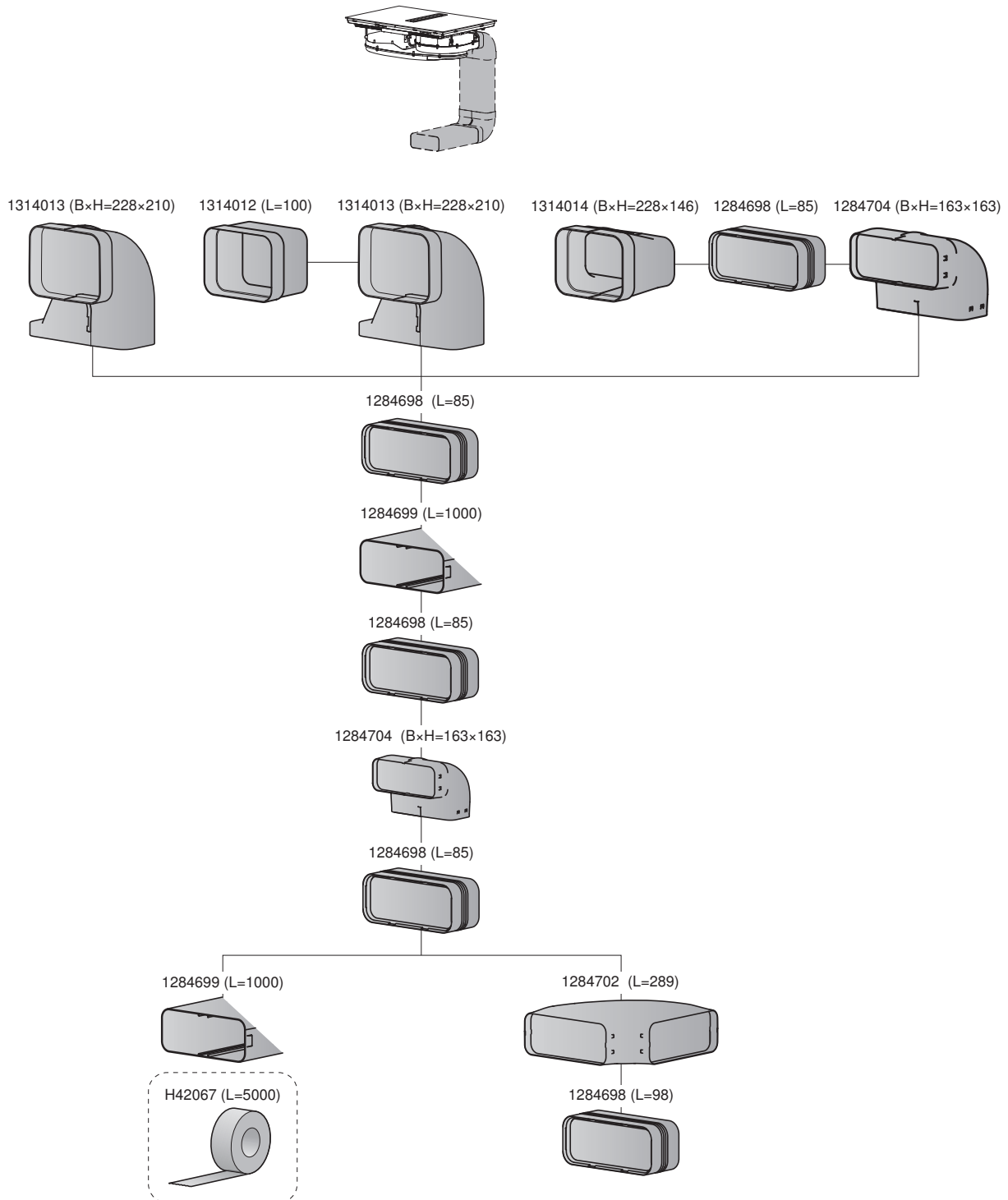

11.9 Flat channel systems made of plastic (PRIME) for the CombiCookTop I804



Plastic accessories are not made of non-flammable material.

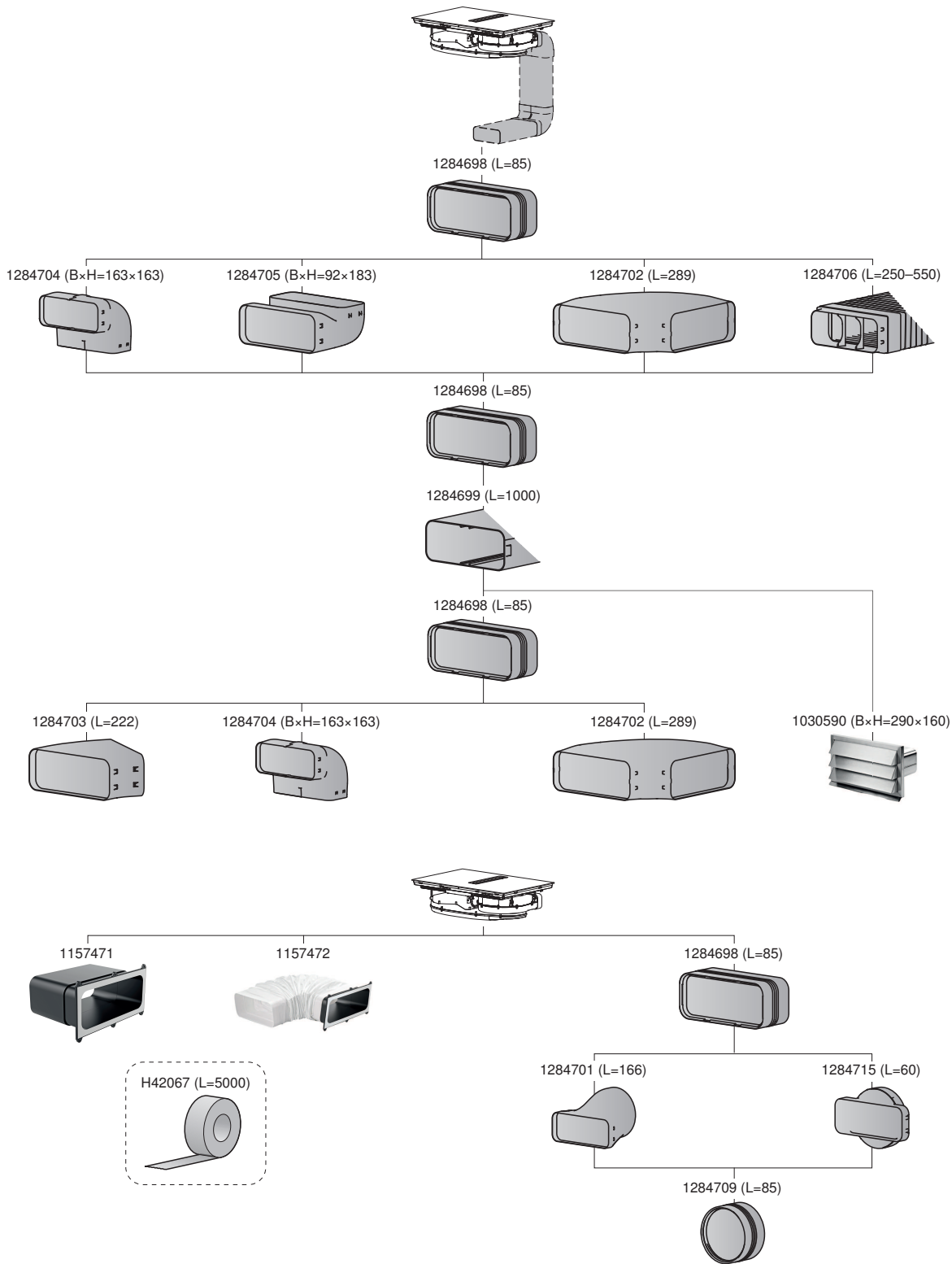

11.10 Flat channel systems made of metal (RF1) for the CombiCookTop I804

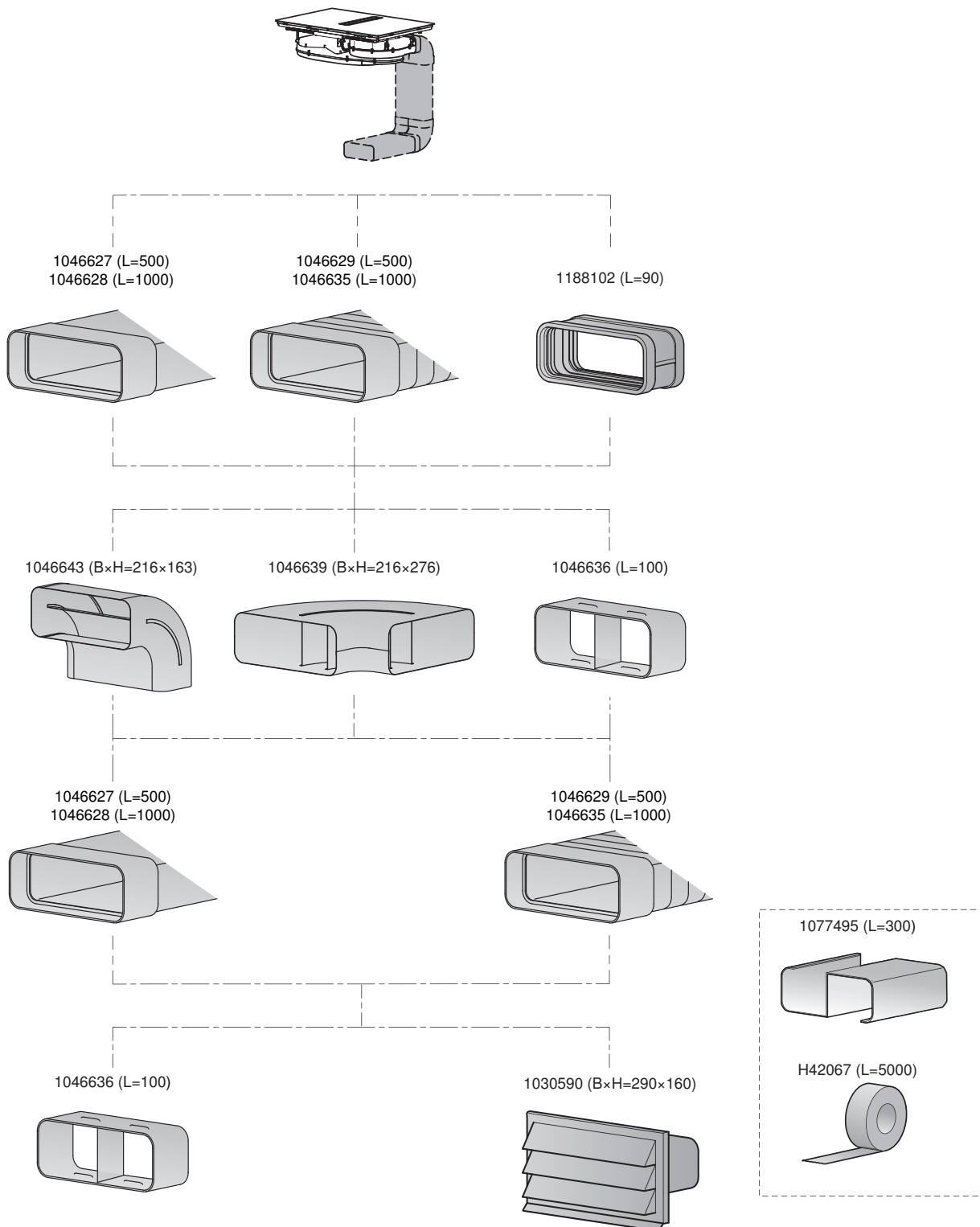

The duct spacers 1077495 prevent the narrowing or compression of the air duct. Hence the use of duct spacers is necessary if accessory 1046627/1046628 is embedded in concrete.

11.11 Recirculation mode



An air outlet of $\geq 500 \text{ cm}^2$ at the exhaust duct of the range hood is recommended. During operation, the air outlet from the exhaust duct of the range hood must not be obstructed. This can be achieved through a shadow gap at the plinth panel or the use of a ventilation grille.



For CombiCookTop I804: Dedicated accessories that need to be fitted to operate the appliance in the recirculation mode: long-life-Plus activated charcoal filter 1155757!

For CombiCookTop I604: The long-life-Plus activated charcoal filter (1225994) or standard activated charcoal filter (1312930) is a dedicated accessory that needs to be fitted in order to operate the appliance in the recirculation mode!

11.12 Extraction mode



There is a danger of toxic fumes developing if the range hood is operated at the same time as an ambient air-dependent firing system!

- If possible, only use pipes with a smooth inner surface for exhaust ductwork.
- Length of flat channel system to air outlet: 6 m channel section with six 90° elbows, 8 m with four 90° elbows or 10 m with two 90° elbows are realizable. If the exhaust duct is to be routed outdoors, we recommend installing a suitable wall box (accessory available for order).
- To achieve the greatest possible air extraction with the lowest noise levels, please observe the following:
 - Use 222 x 89 mm flat channel or pipe with $\geq \varnothing 150 \text{ mm}$ (accessory available for order).
 - The exhaust ducting should be as short and straight as possible and must not be kinked or compressed.
 - Only use connection elbows with large radii.
 - Ensure all pipe connections are secure and airtight.

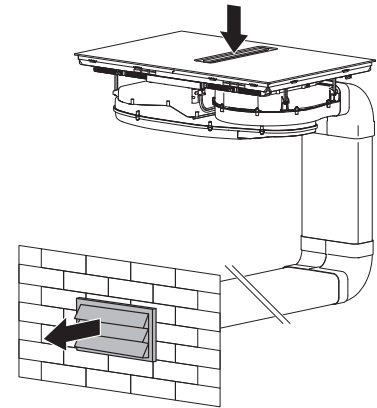

Lateral exhaust air outlet via plinth

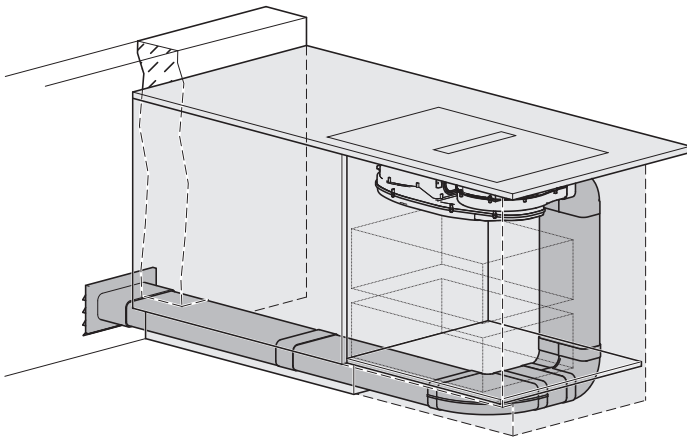

Lateral exhaust air outlet via plinth

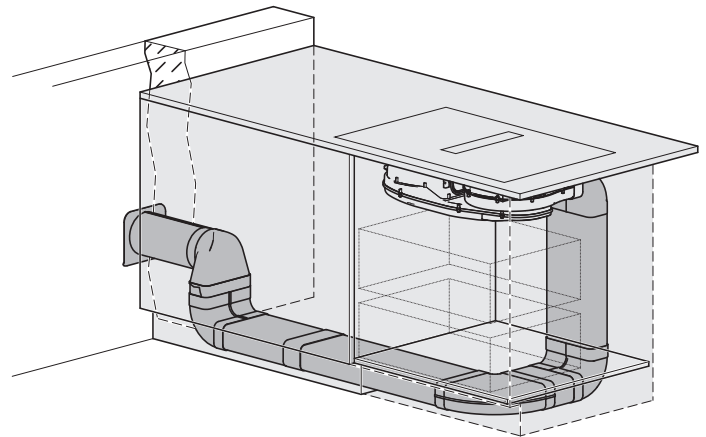



Lateral exhaust air outlet

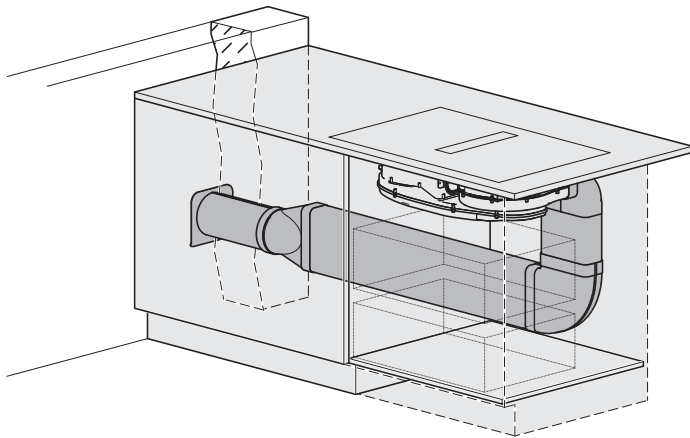

Rear exhaust air outlet with elbow

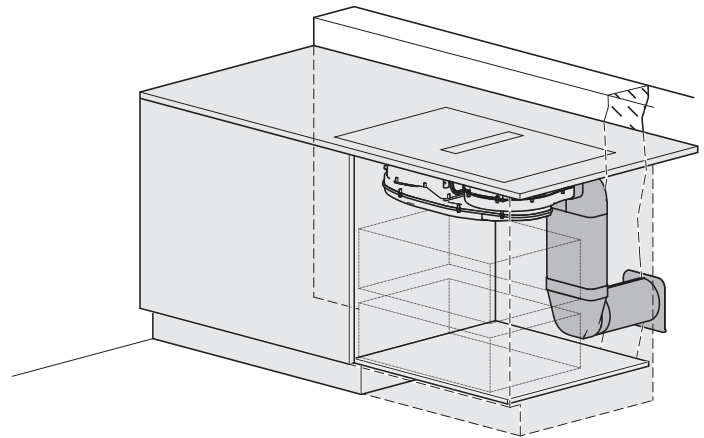

Rear exhaust air outlet straight without elbow

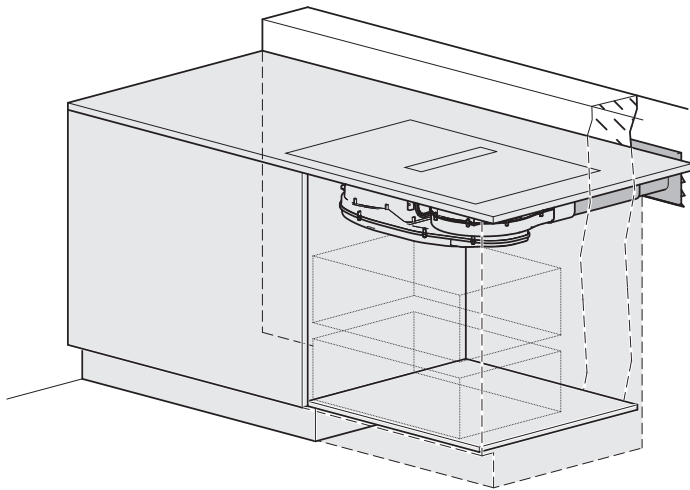

Any constriction of the airflow will reduce extraction performance and increase operating noise.

- If the exhaust duct is to be routed outdoors, we recommend installing a wall box (available as an accessory).
- If the exhaust air is to be ducted into a chimney flue, the intake piece must be aligned with the flow direction of the flue.
- If the exhaust duct runs through cool rooms, lofts, etc., there may be sharp variations in temperature in individual areas. Vapour and condensation is to be expected. This makes it therefore necessary to insulate the exhaust ducting / air duct.

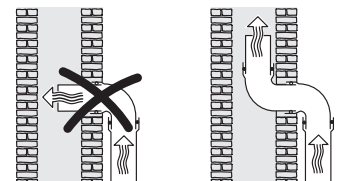

Performance diagram: Exhaust air flow volume

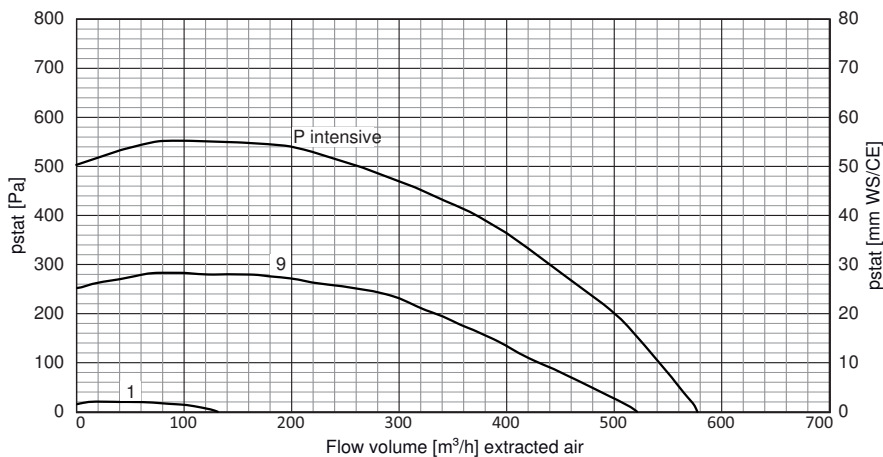

12 Range hoods



Technical information on the range hoods can be found in document «TechInfo for range hoods» under J32836 (EN), 1007182 (IT), 1008408 (DE), 1008409 (FR).

12.1 General notes



If other firing systems are being used at the same time (e.g. wood, gas, oil or coal fired heating appliances), safe operation is only possible providing a room negative pressure of 4 Pa (0.04 mbar) is not exceeded at the location of the appliance.

Risk of toxic fumes! An adequate flow of fresh air must be guaranteed e.g. via non-closable openings in doors or windows and in combination with an air-intake/exhaust-air wall box or by other technical means. Local fire protection regulations must be observed. V-ZUG offers exhaust ducts made of plastic (construction material category RF3) and metal (construction material category RF1).



If the appliance has an options connection, it can be used to open and close an automatic exhaust air / supply air flap. See also Accessories: Control set option, for external roof ventilation fans, room fans and other applications.



Efficient repairs can only be guaranteed if it is possible to uninstall the whole appliance at any time without causing any damage.

Minimum distance to the hob



If a V-ZUG appliance is being combined with a third-party brand (hob or range hood) and the stipulated minimum distance between the combined appliances is different, then the greater of the two must be observed. The minimum distance is measured between the bottom edge of the range hood and the bottom of the pot or pan. If the appliance is installed over gas hobs, each cooking zone must be fitted with an ignition fuse.

Extraction mode



The air must not be discharged into a flue that is used for exhausting fumes from appliances burning gas or other fuels.
Observe the local fire safety regulations.

Installation notes

- In addition to the correct dimensioning of the exhaust duct, it is also necessary to ensure a sufficient inflow of fresh air. **to replace the air that is being extracted.**
- Avoid routing the exhaust duct to the side through the chimney casing.
- Planning features for non-destructive de-installation and maintenance of the appliance:
 - Do not route telescopic casing in suspended ceilings.
 - Avoid silicone joints between the telescopic casing and the appliance.
 - All plastering, plasterboarding, wall papering and painting work is to be carried out prior to installing the appliance.



12.2 Special hoods



Special hood type DSTS9 (64015) may not be used in combination with gas hobs.
 Special hood type DSMS (64005) may only be operated in combination with a gas hob of V-ZUG gas hob type: GAS321x, GAS421x, GAS641x, observing the permitted combination installation variants. The content of the operating and installation instructions for the listed gas hobs must be observed! If operating a permitted gas appliance, the hob hood must be fitted with the dedicated gas deflector 1031218 (accessory)! Operating a gas appliance without the gas deflector is not permitted!

DSMS downdraft hood (64005)

Operating mode	Extraction/Recirculation	Mains connection	220–240 V~ 50–60 Hz
Noise level	62–70 dB (A)	Fuse	10 A
Illumination	-	Fan speeds	4
Motor	1 x 145 W	Weight	~21.5 kg

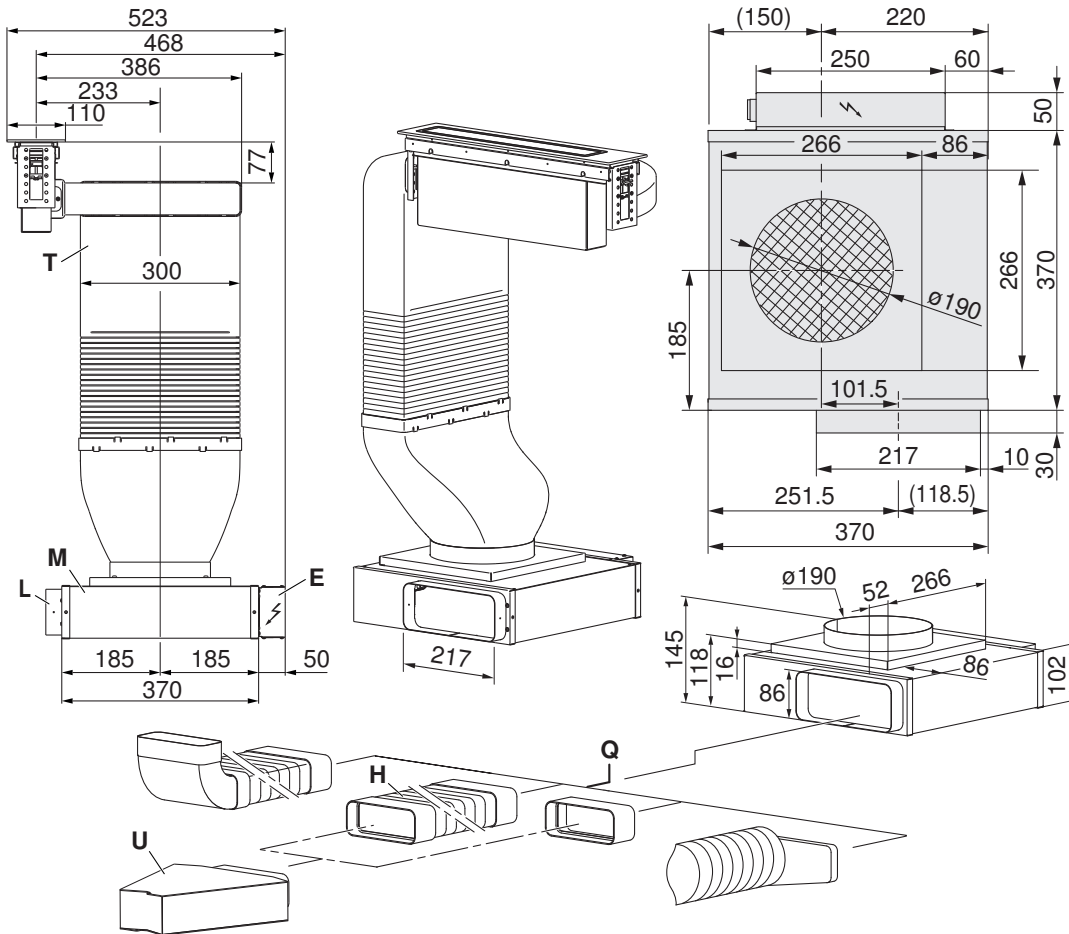

Suitable flat channel systems Q are available for order as accessories.

- The connection between the hob hood and the exhaust air duct T can be to the left or right.
- The ventilation outlet L can be fed through one of the four sides, however this can change the installation type.
- Depending on space requirements, the exhaust air duct T can be adjusted through shortening.
- The control unit E can be repositioned (≤250 mm) if required.
- Plan a removable **base plate** or **service flap** for fan motor M and recirculation box U (for recirculation mode).
- Access to the fan motor M and the recirculation box U is facilitated through extendible flat channel systems Q. Recommendation: Flat flexible elbow H, article no. 1012786, with flexible length (240–600 mm).
- For the recirculation mode, ensure sufficient ventilation so that moisture can escape. Plan in suitable material/wood.

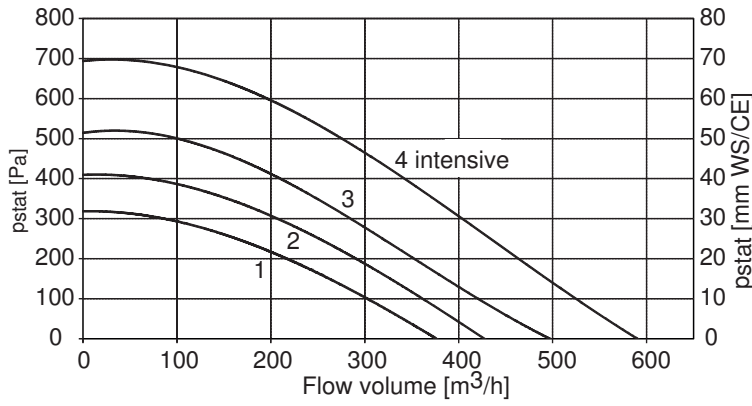

Scope of delivery

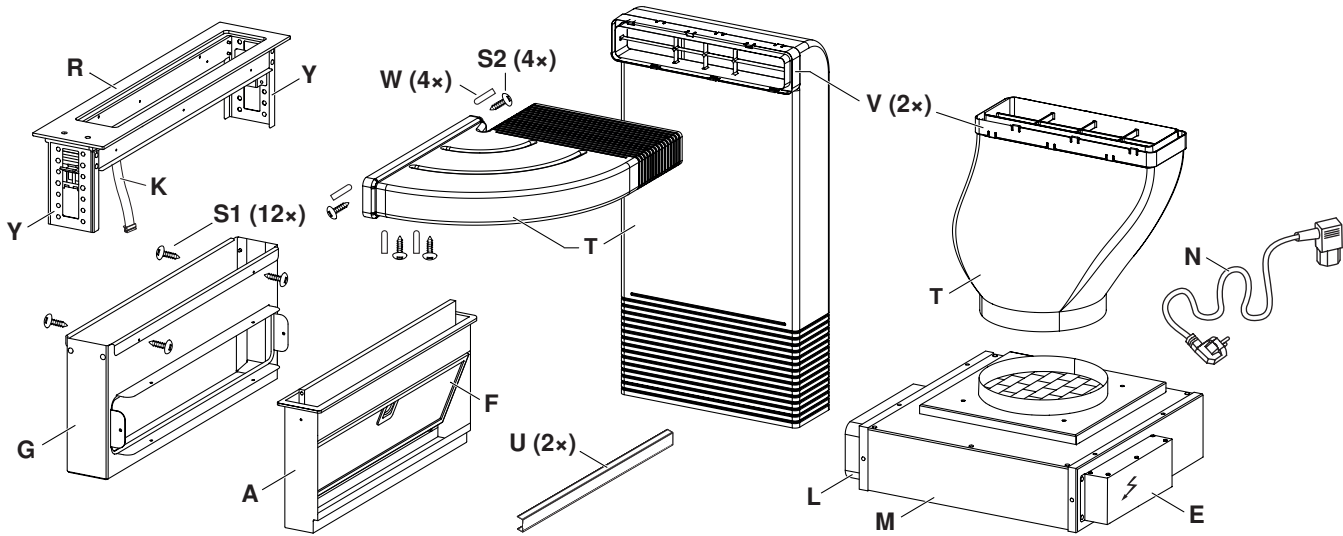

- | | |
|------------------------------|--|
| A Drip tray frame | N Mains cable length 1.8 m |
| E Control unit | Q Flat channel system |
| F Metal grease filter | R Frame |
| G Appliance housing | T Exhaust air duct |
| K Control cable | U Spacer profile |
| L Ventilation outlet | V Connecting elements |
| M Fan motor | W Plastic covers |
| | Y Mounting angle (surface-mounted installation) |

Accessories:

Recirculation box 1157470

A flat channel system can be used for the installation (see the following pages and Accessories).

Gas deflector 1031218, required accessory when using a permitted V-ZUG gas hob. Operating a gas appliance without the gas deflector is not permitted!

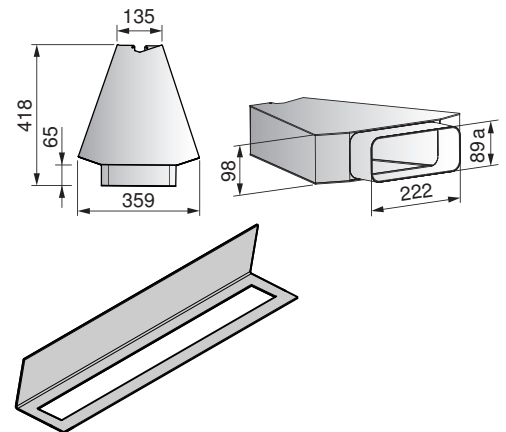



Plastic accessories

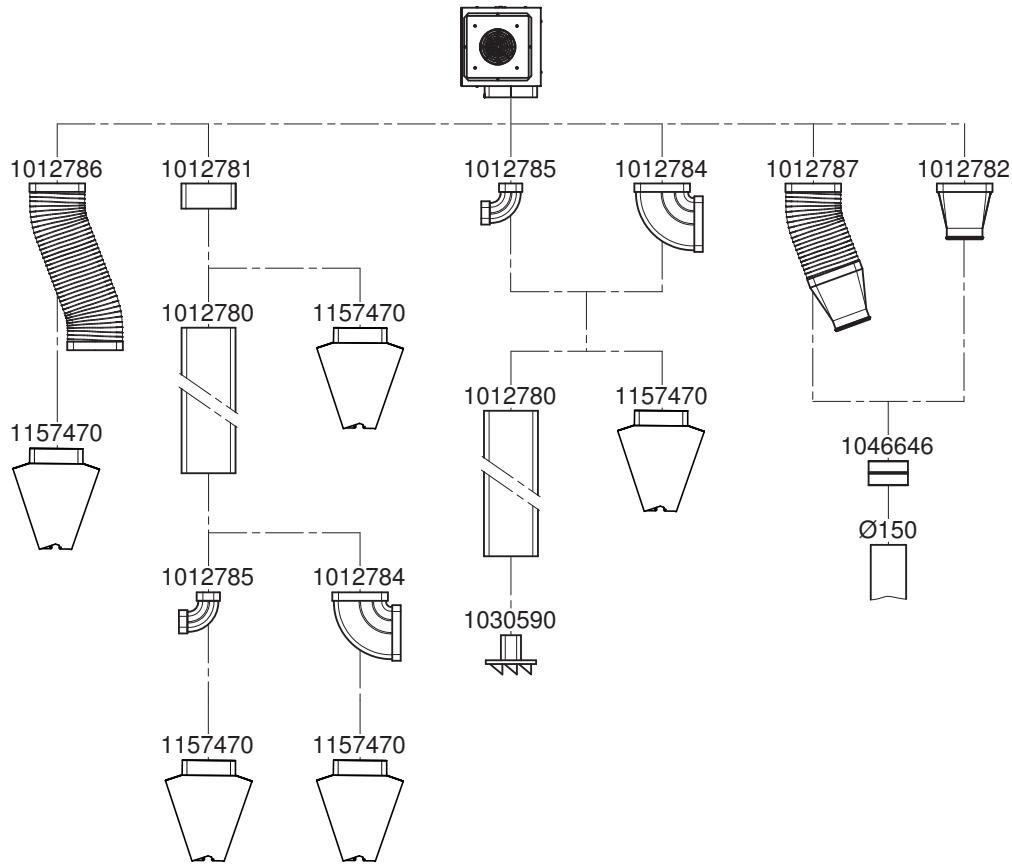

Flat channel systems made of plastic (PRIME)

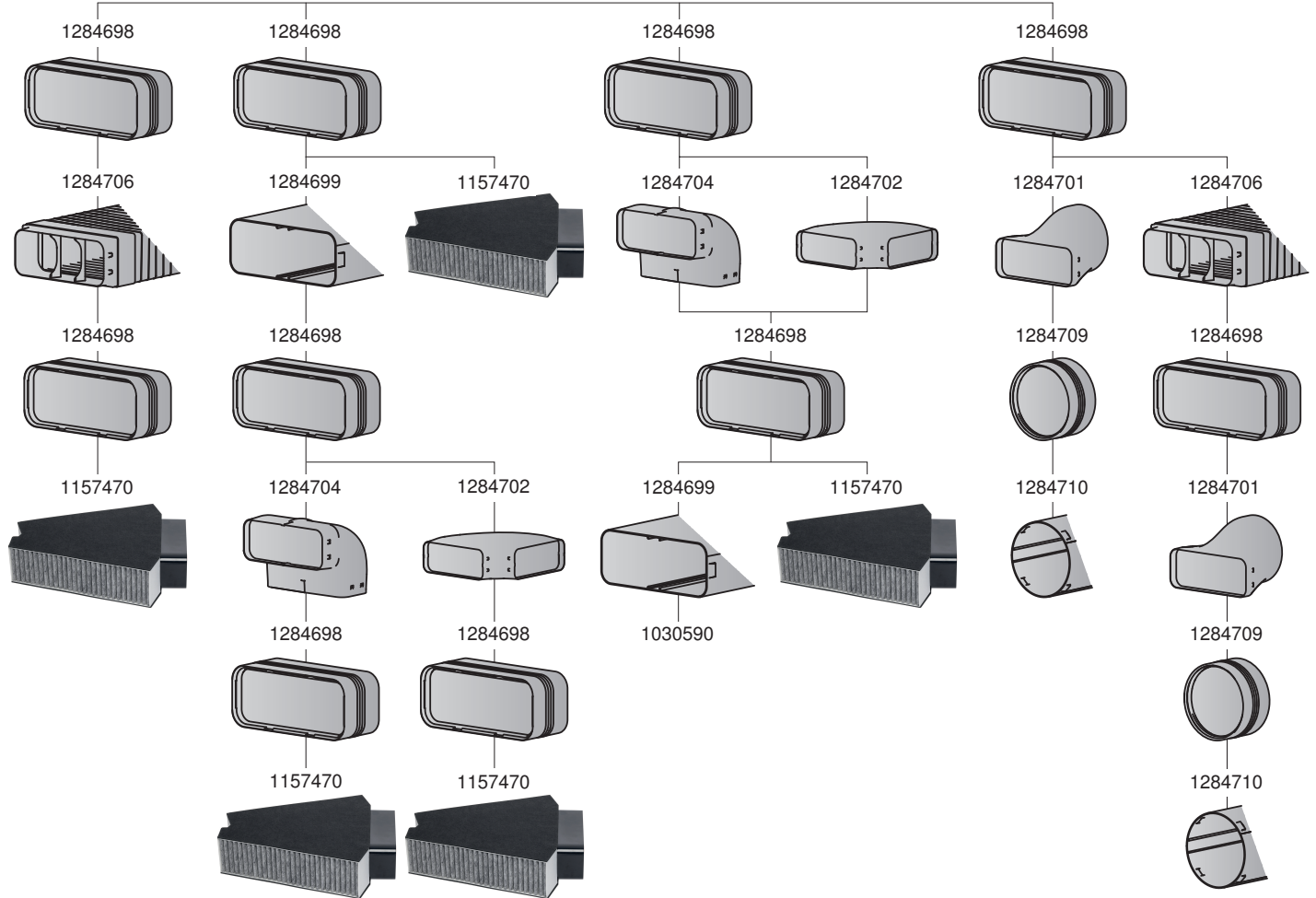
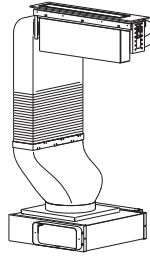

Metal accessories

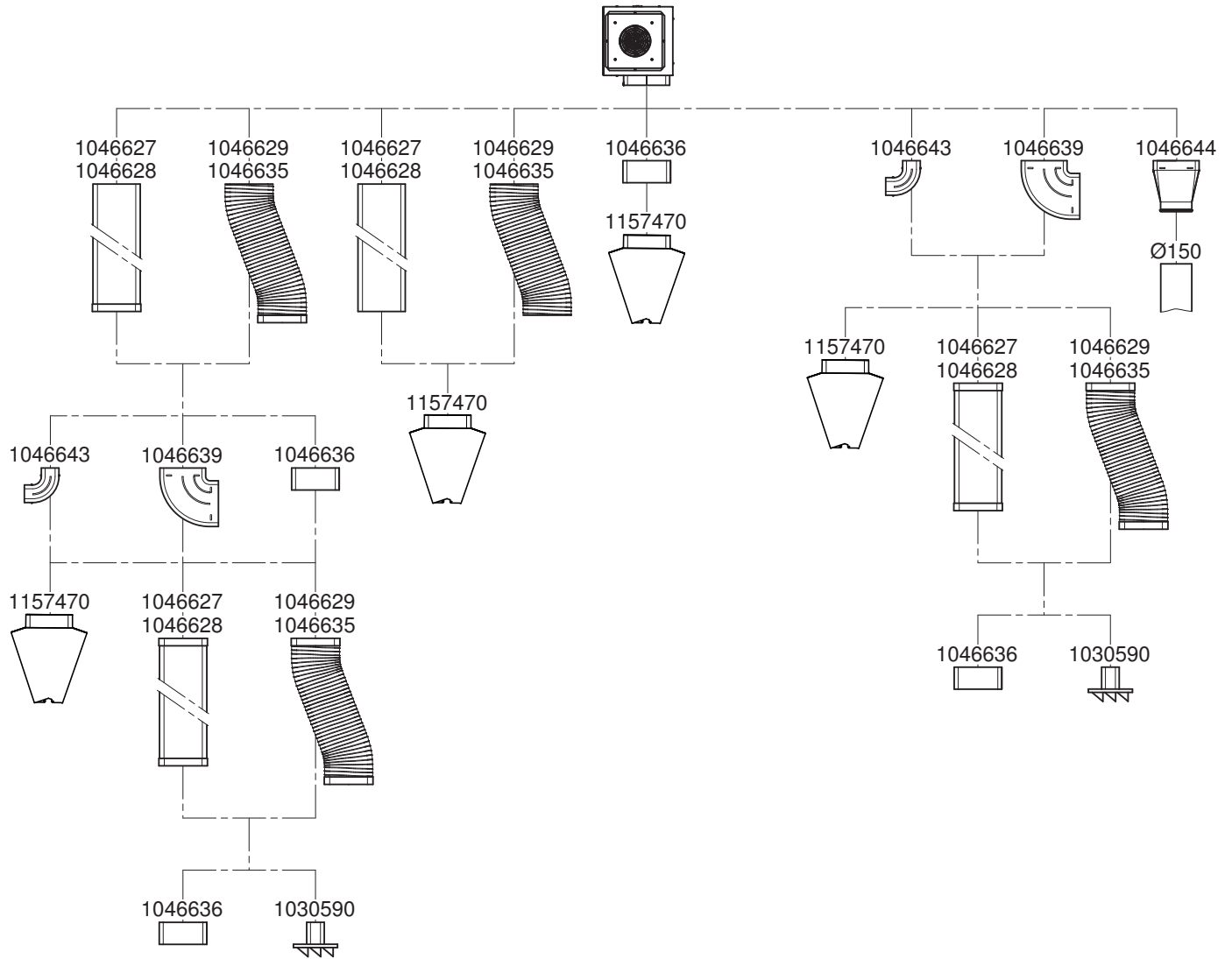

Combination installation

Flush installation

Flush-mounted installation with additional intermediate supports **K** requires the accessory **intermediate support set H63789** (contains two intermediate supports). Flush-mounted combination installation is described in document 1014378.

A WOK glass ceramic hob cannot be surface mounted!
Reason: Glass thickness is 6 mm.

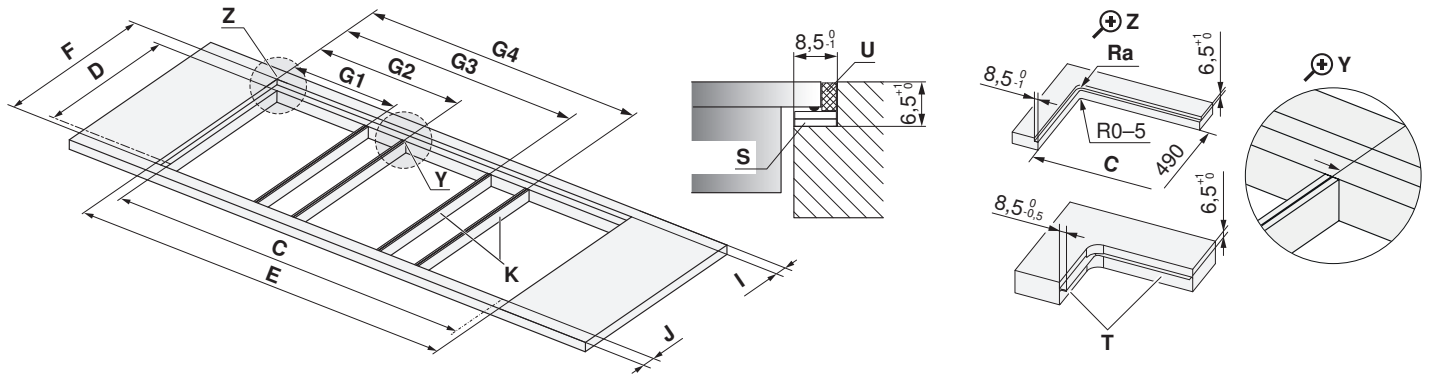

- F** 507±1 mm
- D** 490±1 mm
- I** ≥41.5 mm
- J** ≥41.5 mm
- Ra** 5 mm

- Ra** Outer corner radii of cut-out
- K** Intermediate support
- S** Spacer plates
- T** Steel angle bonded or screw mounted
- U** Silicone joints

Combinations	Cut-out width E	Cut-out width C	Intermediate support position G1	Intermediate support position G2	Intermediate support position G3	Intermediate support position G4
40+11+40 cm	890 mm	873 mm	388.5 mm	501.5 mm	-	-
11+80+11 cm	993 mm	976 mm	114.5 mm	878.5 mm	-	-
40+11+40+11+40 cm	1390 mm	1373 mm	388.5 mm	501.5 mm	888.5 mm	1001.5 mm
40+11+60+11+40 cm	1577 mm	1560 mm	388.5 mm	501.5 mm	1075.5 mm	1188.5 mm
40+11+70+11+40 cm	1697 mm	1680 mm	388.5 mm	501.5 mm	1195.5 mm	1308.5 mm
40+11+80+11+40 cm	1767 mm	1750 mm	388.5 mm	501.5 mm	1265.5 mm	1378.5 mm

Surface-mounted installation

Surface-mounted installation requires the accessory **side strip set 1028587** and either the intermediate support **K 1019199** (black) or **1014361** (stainless steel). Articles are available for order as accessories. Surface-mounted combination installation is described in document 1013770.

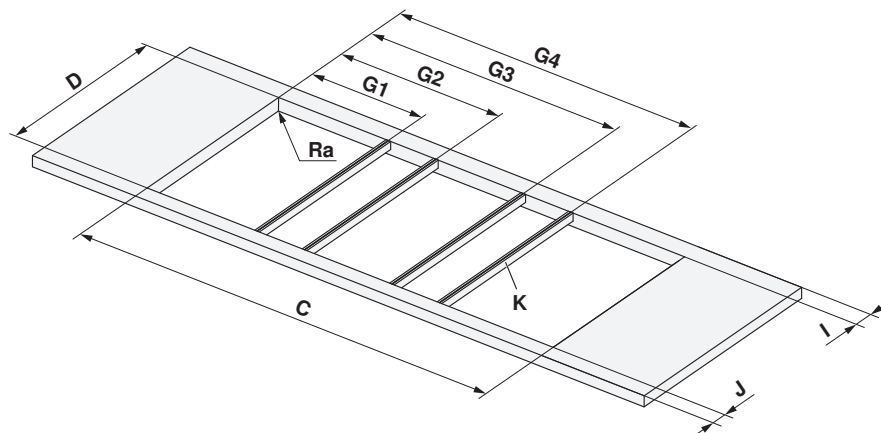

- D** 490±1 mm
- I** ≥50 mm
- J** ≥50 mm
- Ra** 0–5 mm
- Ra** Outer corner radii of cut-out

Combinations	Cut-out width C	Intermediate support position G1	Intermediate support position G2	Intermediate support position G3	Intermediate support position G4
40+11+40 cm	873 mm	380 mm	493 mm	-	-
40+11+40+11+40 cm	1373 mm	380 mm	493 mm	880 mm	993 mm
40+11+60+11+40 cm	1560 mm	380 mm	493 mm	1067 mm	1180 mm

Installation overview for base

Wall installation, depth ≥ 600 mm

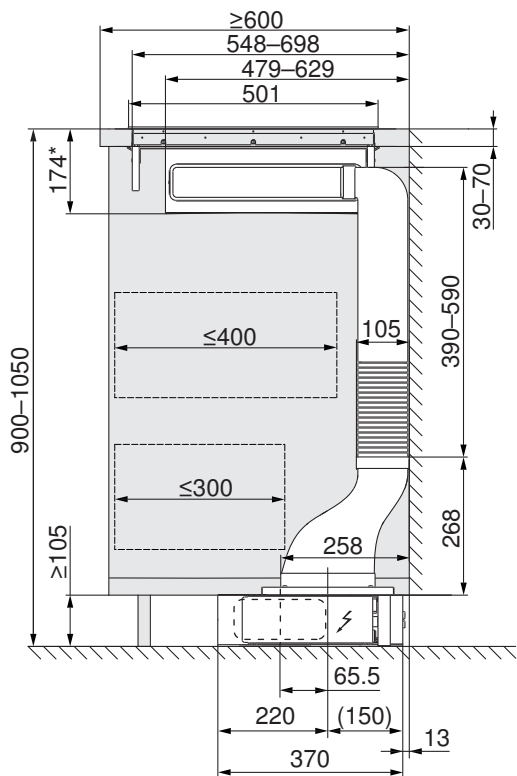

Wall/Island installation, depth ≥ 700 mm

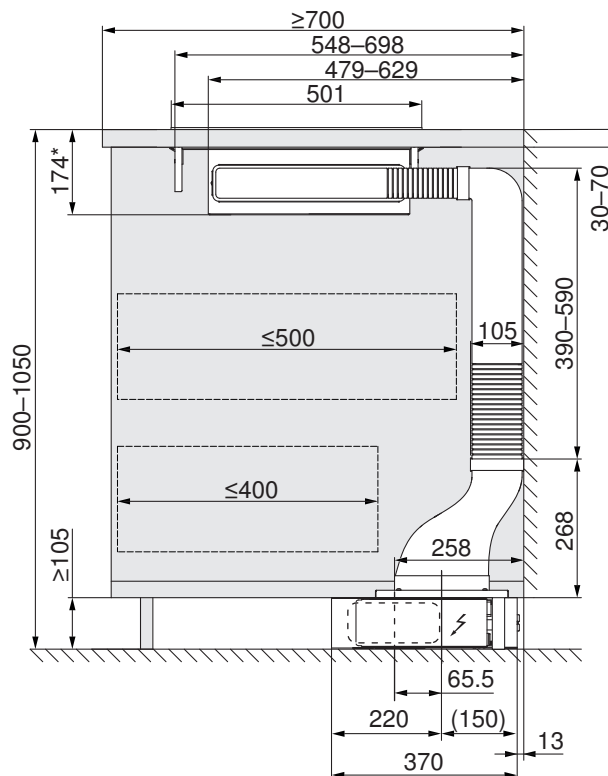

Island installation, depth ≥ 900 mm

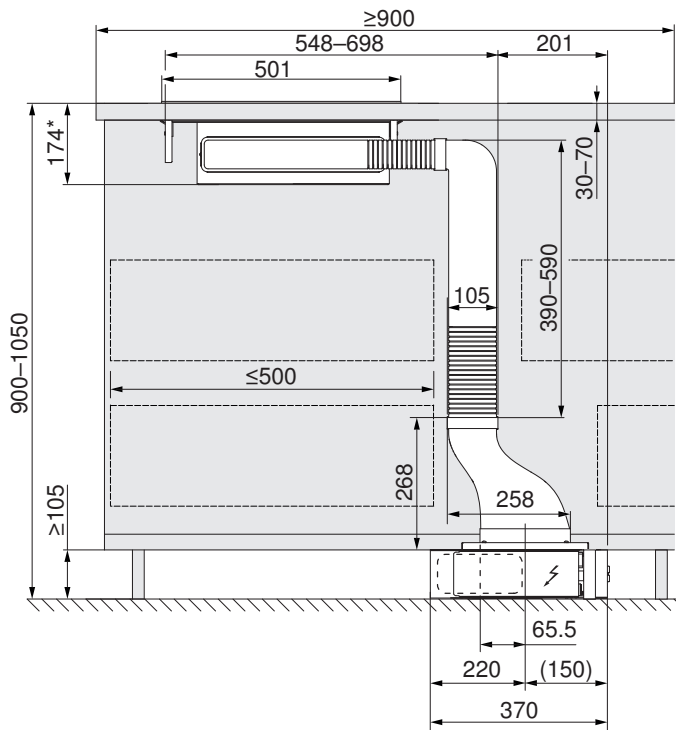

Variant with rotated fan motor

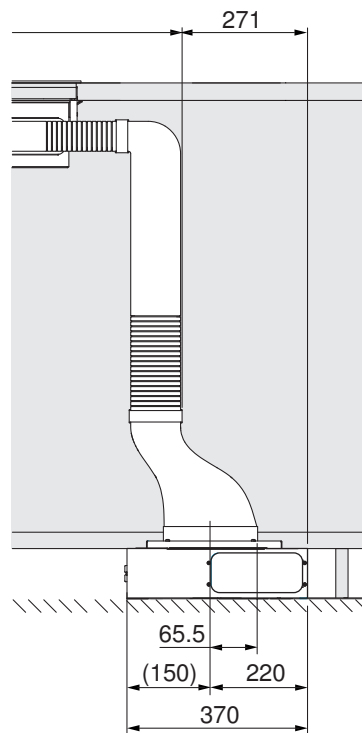

* Flush installation. Surface-mounted installation: 170 mm.

Appliance selection and combination possibilities

1. Planning example: Two hobs

Air duct in base to left/right.

The WOK glass ceramic hob / gas hob **W** is **always** positioned on the opposite side of the exhaust air duct. Standard hob **S**.

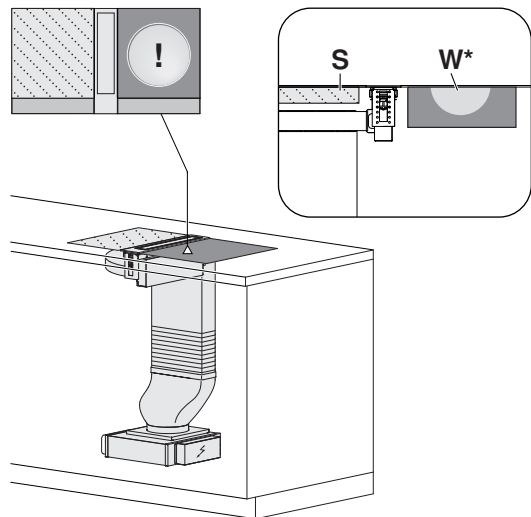

 **A WOK glass ceramic hob and gas hob may not be combined! In general, the use of a gas wok, in any combination, is not permitted.**

2. Example: Three hobs

Air duct in base on both sides to left/right.

The Teppan Yaki hob **P** (600 mm) is positioned in the middle. The WOK glass ceramic hob / gas hob **W** is **always** positioned on the opposite side of the exhaust air duct. Standard hob **S**.

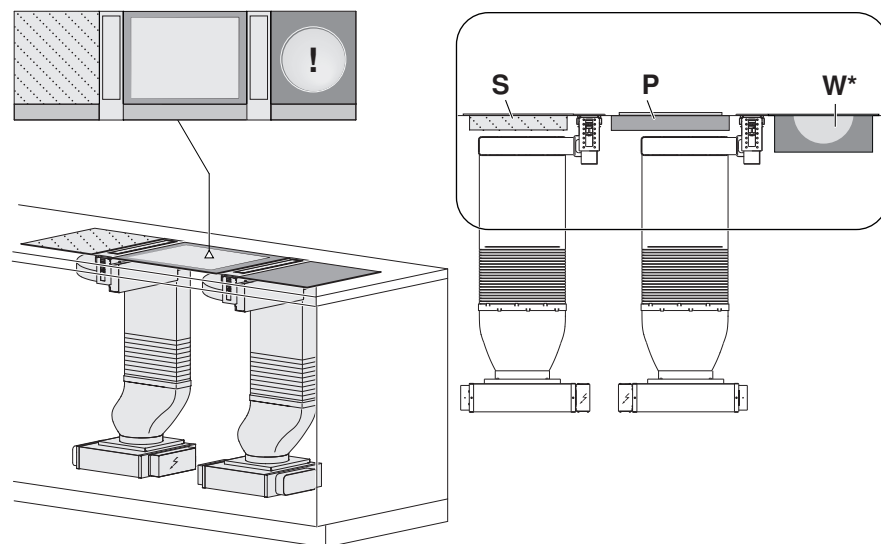

3. Example: Three hobs

Air duct in base on both sides to outside.

The WOK glass ceramic hob / gas hob **W** (400 mm) is positioned in the middle. Standard hob **S**. Possible position of 2 fan motors **M**.

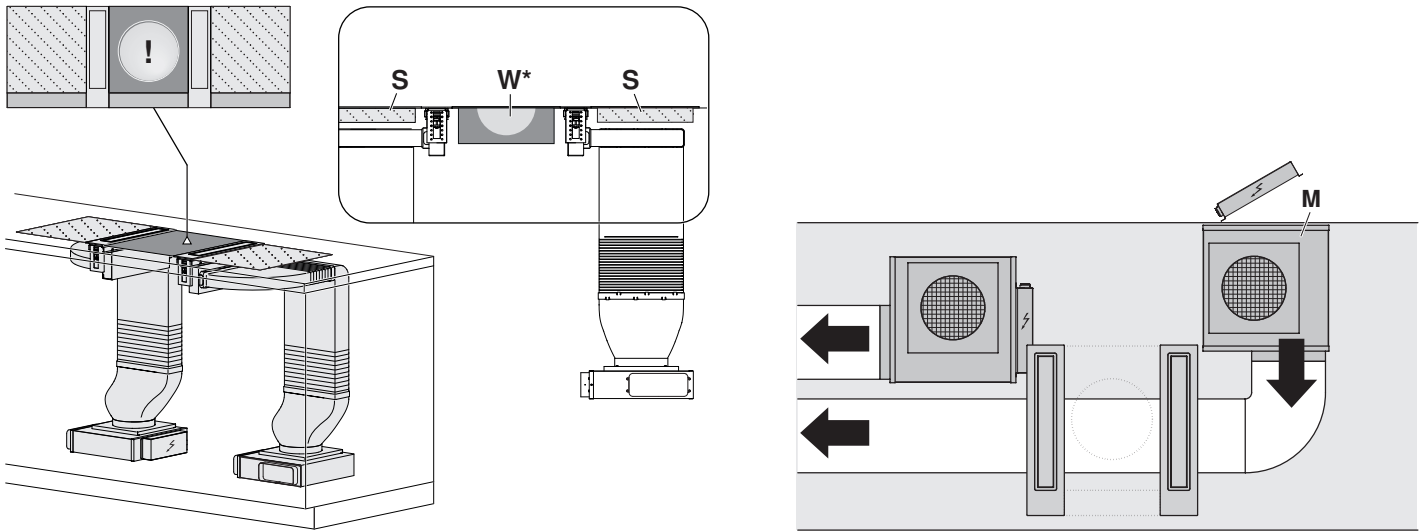

4. Example: Large hob positioned in the middle

Air duct in base on both sides to inside for space economy.

Allows standard hob **S** with ≤ 800 mm installation width to be positioned in the middle. The WOK glass ceramic hob / gas hob **W** can **not** be positioned in the middle. Possible position of 2 fan motors **M**.

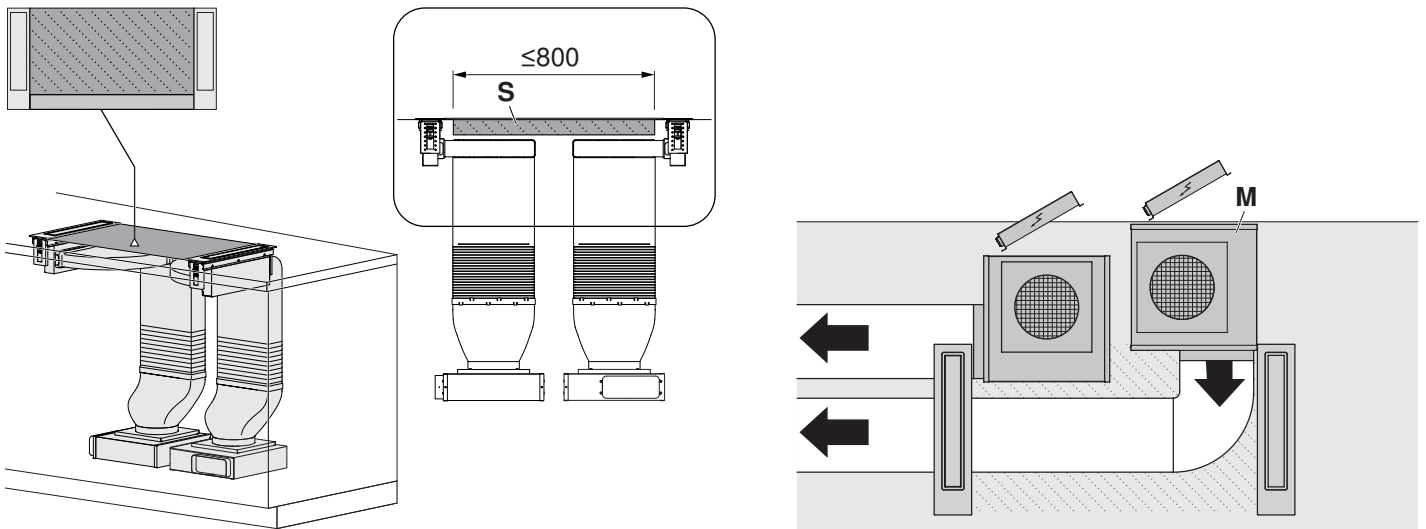

For use with a gas appliance



The hob hood may only be used with the dedicated gas deflector 1031218 (accessory) with one of the gas appliances listed below. Operating the hob hood without the gas deflector is not permitted!



Permitted gas appliances for use with the hob hood:

V-ZUG gas hob type: **GAS321x, GAS421x, GAS641x**, observing the permitted combination installation variants.



Combining the hob hood with two gas hobs is not permitted!



Using another gas appliance type/model or manufacturer is not permitted and can cause lasting damage to the hob hood.

Failure to observe the above instruction can cause lasting bodily harm and lasting damage to property and the appliance. In such a case, any and all liability, guarantee and goodwill claims will be rejected, now and in the future!



Risk of burns!

The appliance and surrounding components get hot during operation! Allow the fan flap, gas deflector and other components to cool down before touching them.



Fire hazard!

Grease deposits can build up in the grease filter and catch fire. Clean the grease filter regularly. Only operate the appliance with the gas deflector.

Permitted installation variants (V-ZUG gas hob only)

As a variant may also be installed on either side of the appliance.

A Caution: Hot surface!

B Gas deflector correctly mounted.

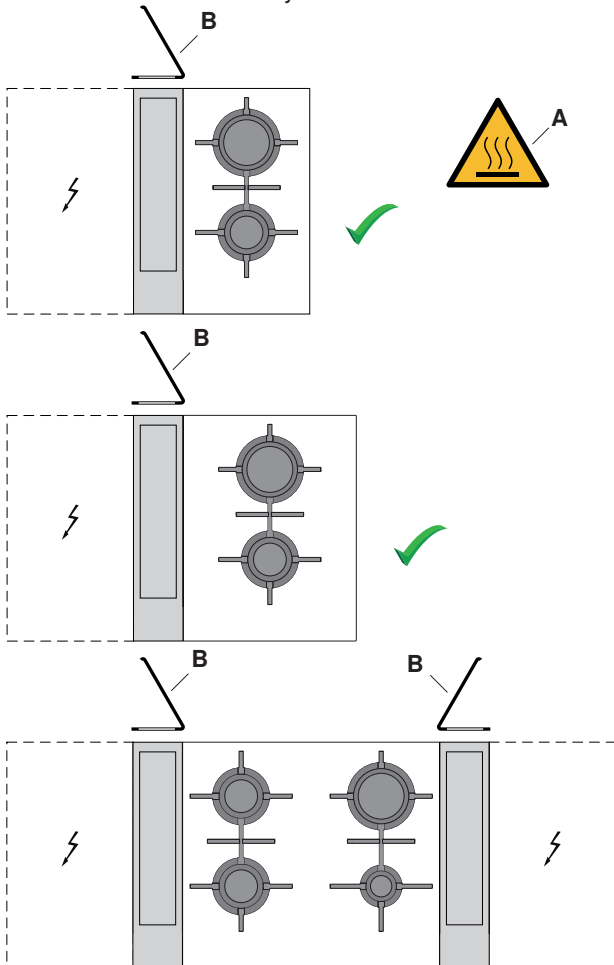

The gas deflector 1031218 (required accessory) reduces the deflection/disturbance of the gas flame at the burner and prevents it being extinguished by a draft.

- ▶ Open fan flap 1.
- ▶ Set the gas deflector 2 in the correct position relative to the gas appliance.
- ▶ Switch on hob hood 3.

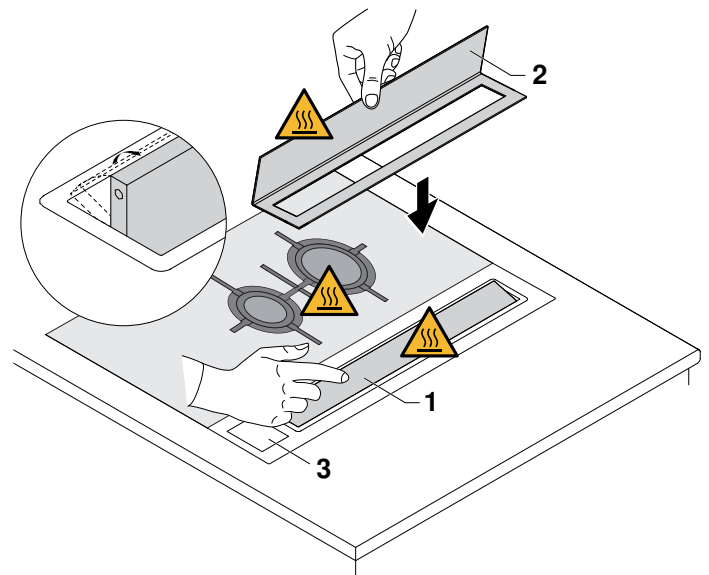

Installation variant for recirculation hob hood with «recirculation box»

Example: Recirculation mode with recirculation box

Flat flexible elbow **H**, article no. **1012786**, with flexible length (240–600 mm) easy installation/access to fan motor **M** and recirculation box **U**.

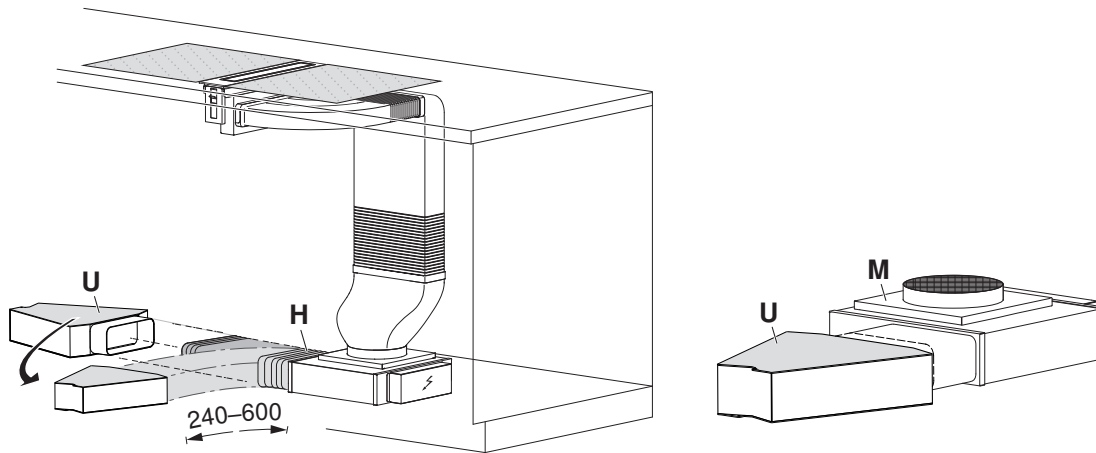

Plan in enough space for maintenance work and ensure access to the fan motor and the recirculation box (for replacing the activated charcoal filters)! Exhaust air outlet cross section: plan min. 500 cm² for exhaust air in base area.



Dedicated accessories that need to be fitted to operate the appliance in the recirculation mode: article no. 1157470 recirculation box with activated charcoal filters!

Installation variant for extraction hob hood

Example: Extraction mode with flat channel (round channel also possible).

Plan in length of flat channel system to air outlet of **max. 7000 mm**. If the exhaust duct is to be routed outdoors, we recommend installing a telescopic wall box (accessory available for order).

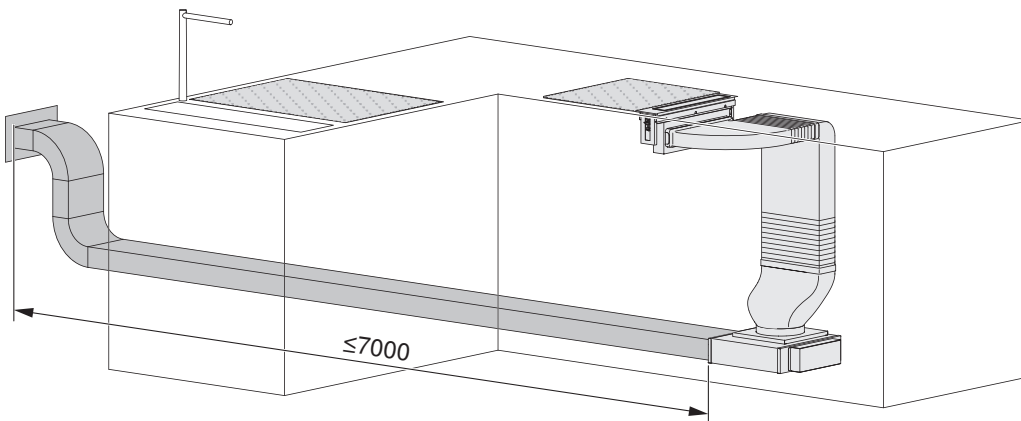

Ensure enough space for maintenance work and access to the fan motor and flat channel system!



DSTS downdraft hood (64015)

Operating mode Extraction/Recirculation
Noise level 43–68 dB (A) / 42–69 dB (A)
Illumination 1 × 5 W
Motor 1 × 250 W
Surface-mounted installation variant

Mains connection 220–240 V~ 50–60 Hz, 255 W
Fuse 10 A
Fan speeds 4
Weight ~35 kg
Flush installation variant

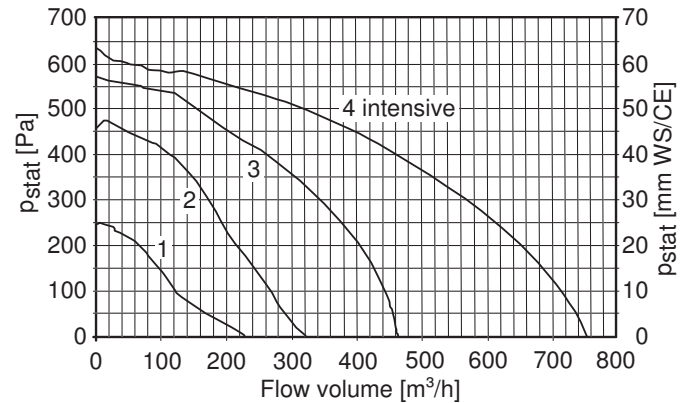
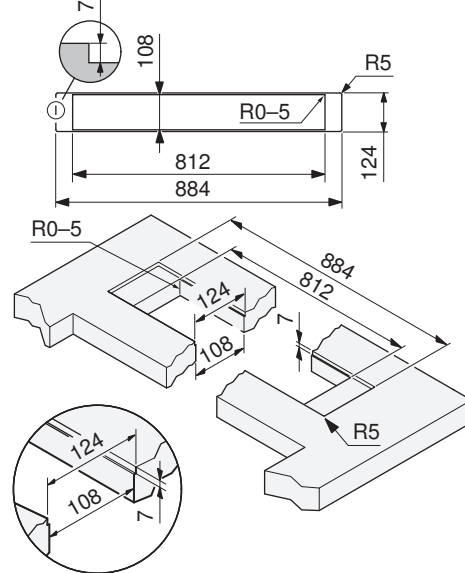
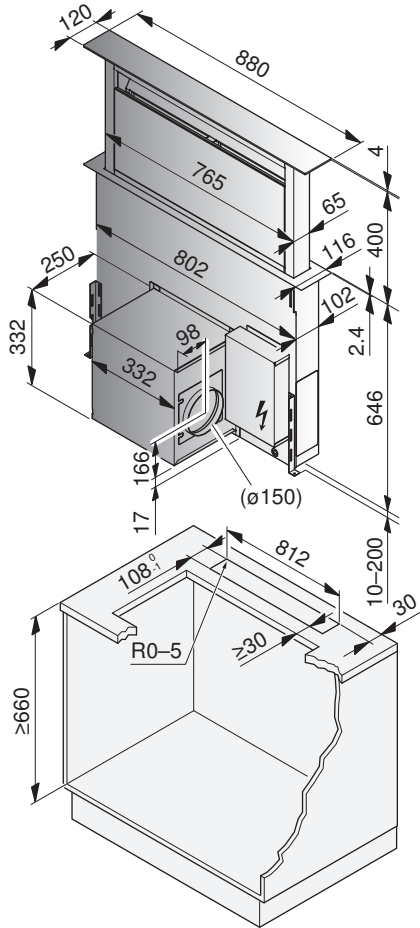

Recommendation: Hobs of the construction type «Panorama» and «Domino».

- As an alternative, the motor housing may be planned and mounted to the range hood from the back, though access must be guaranteed from the front for service and installation.
- The exhaust connection can be positioned to point in one of four directions.
- If using recirculation box 1157470, a transition piece 1012782 or H42078 is needed for its installation. A flat channel system can be used for the installation (see Accessories).

Accessories:

Recirculation box with activated charcoal filters 1157470

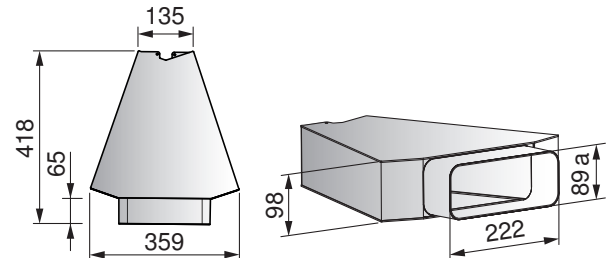

or
 Long-life activated charcoal filter 1012163

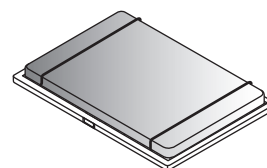

Exhaust air outlet cross section: plan min. 500 cm² for exhaust air in base area.

Downdraft hood

The fan can be rotated for mounting. The exhaust air can thus be extracted upwards, left, right or downwards. The fan can also be mounted in the same position at the back of the appliance. If the fan is to be mounted at the back of the appliance, then the rear panel of the cabinet has to be cut out where the fan is to be mounted and ensure sufficient installation space behind the cabinet. Access must be guaranteed from the front for service and installation. The electricians can, if required, be positioned to the left of the fan, on the hood body or in the cabinet. Variants with external motor as an option are also possible.

Installation variants

Downdraft extraction hoods

For this installation variant, the base fan feeds the exhaust air through the exhaust air pipe or in a space-saving way through a flat channel through the wall.

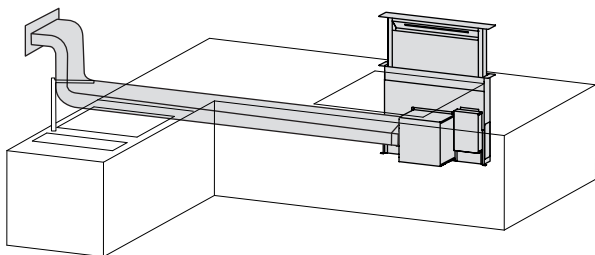

Downdraft recirculation hoods with «activated charcoal filters»

The activated charcoal filters are placed at the front, behind the grease filter, for this installation variant. For example, the exhaust air can be fed back into the room through a shadow gap.

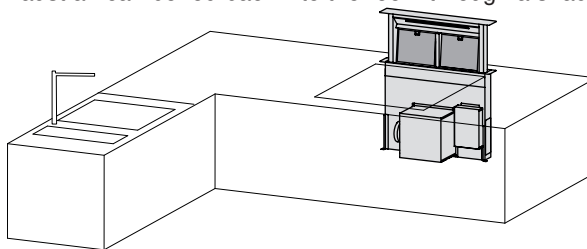

Exhaust air outlet cross section: plan min. 500 cm² for exhaust air in base area.

Downdraft recirculation hoods with «recirculation box»

The recirculation box is connected to the flat channel in an upright position for this installation variant. For example, the exhaust air can be fed back into the room through a shadow gap. Plans must include an inspection opening for replacing the filter in the recirculation box for this construction variant.

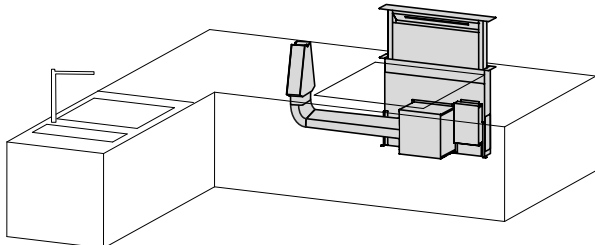

Exhaust air outlet cross section: plan min. 500 cm² for exhaust air in base area.

Downdraft recirculation hoods with «recirculation box»

The recirculation box is connected to the base fan for this installation variant. For example, the exhaust air can be fed back into the room through a shadow gap. Plans must include an inspection opening for replacing the filter in the recirculation box for this construction variant.

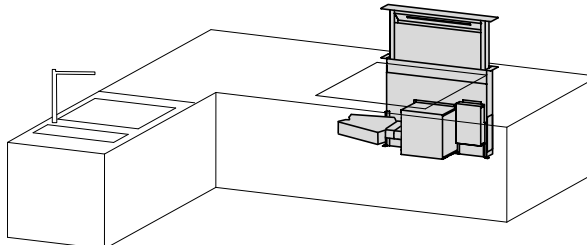

Exhaust air outlet cross section: plan min. 500 cm² for exhaust air in base area.

Downdraft hood with external motor

The motor can be placed externally for this installation variant, e.g. in an adjacent cabinet. A maximum distance of 4 m is recommended. The external motor must be installed on the inside.

External conversion kit, fan 1012164

R Piping is available for order as an accessory
A The conversion kit contains a three-part rectangular to round adapter, ø150.

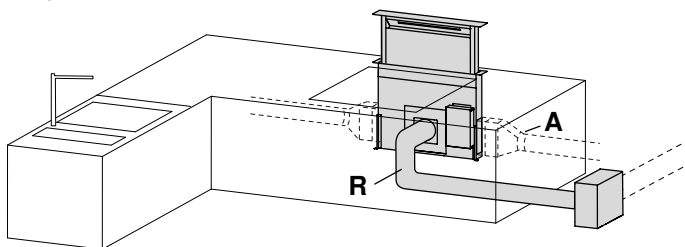



12.3 Built-in range hoods

Applicable to the following hoods:

- Connection cable min. 1.2 m, with plug.

Positions of electrical connections



The specified dimensions are valid for straight exhaust air piping. If exhaust air piping with an elbow are used, the dimensions must be adapted accordingly.

Appliance	Connection from floor (plinth height 100 mm)	Connection in niche (from centre to connection)	Type of connection
All models	2050 mm	180 mm	Flush power socket 220–240 V

AiroClearCabinet V4000 (64009/64010)

Operating mode Extraction/Recirculation
Noise level 49–67 dB (A)
Illumination 2 × 2 W
Motor 265 W

Mains connection 220–240 V~ 50 Hz, 269 W
Fuse 10 A
Fan speeds 4
Weight 19.6 kg / 22.9 kg

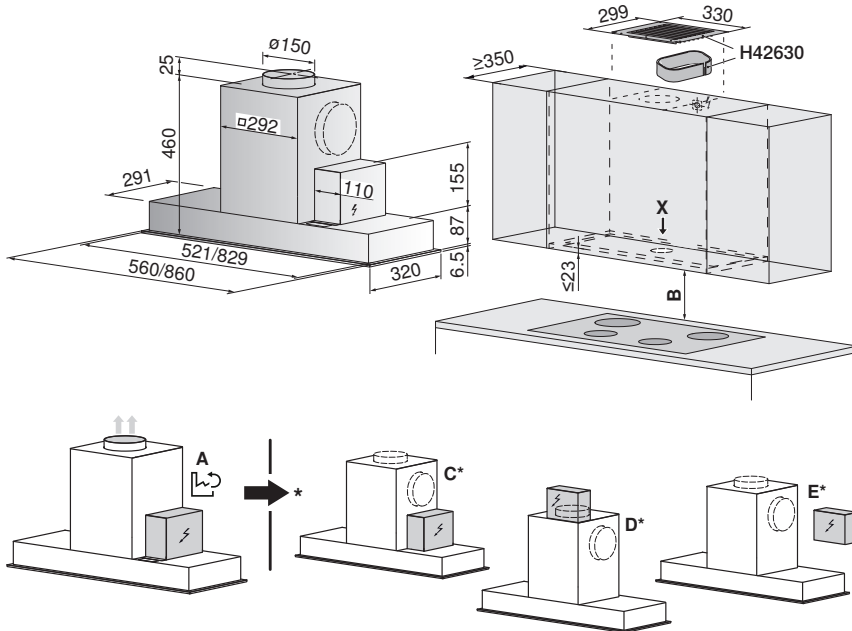

Use of stone cladding

20 mm thick wall panels (granite, marble) are possible.

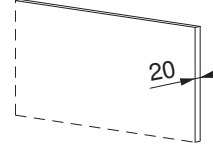

Minimum distance B above hob:

For electric hob: 500 mm, 600 mm (AU/NZ)
 For gas hob: ≥650 mm
 Details: Gas hobs (see page 51)
 General notes (see page 78)

Ex works A

(*) Options C/D/E: Not available for future planning. Options for positioning elec. box and air outlet.

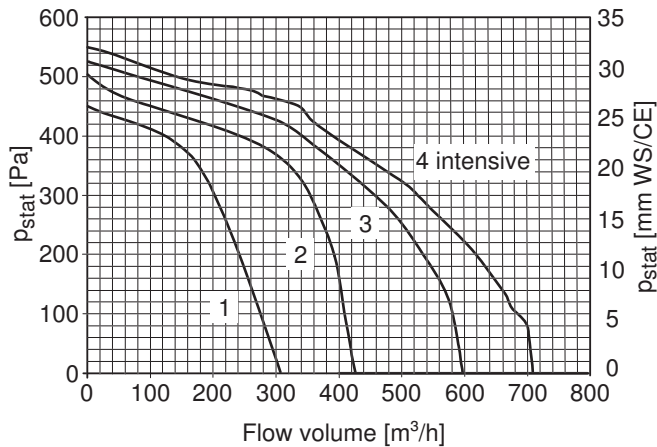

Cut-out for wall unit (view X)

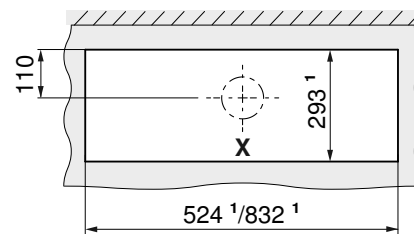

¹ Cut-out measurements



AiroClearCabinet V4000 Twin Blower (64011)

Operating mode
Noise level
Illumination
Motor

Extraction
 56–71 dB (A)
 2 × 2 W
 2 × 265 W

Mains connection
Fuse
Fan speeds
Weight

220–240 V~ 50 Hz, 534 W
 10 A
 4
 27 kg

Use of stone cladding

20 mm thick wall panels (granite, marble) are possible.

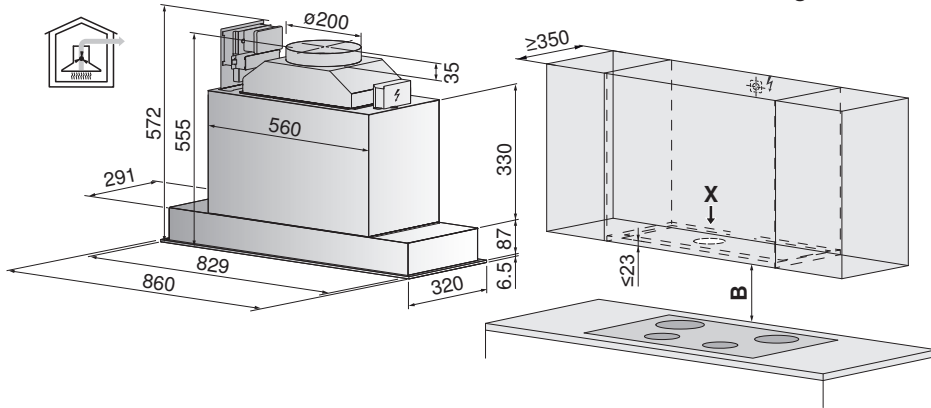

Minimum distance B above hob:

For electric hob: 500 mm,
 600 mm (AU/NZ)
 For gas hob: >=650 mm
 Details: Gas hobs (see page 51)
 General notes (see page 78)

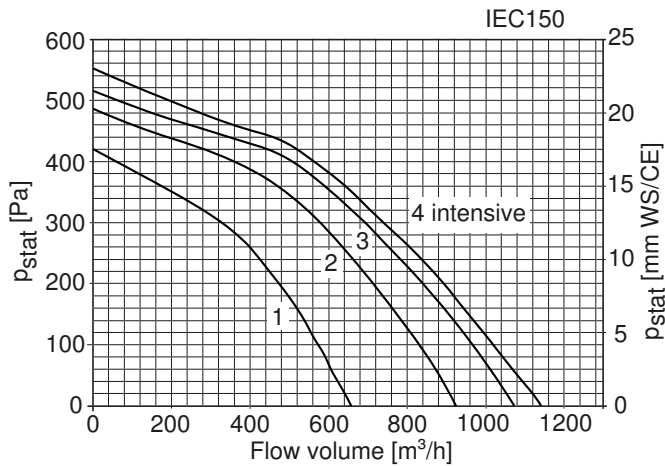

Cut-out for wall unit (view X)

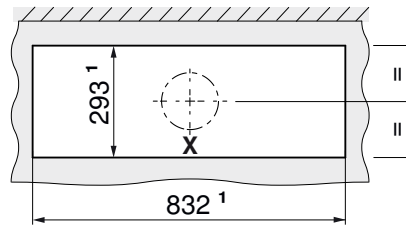

¹ Cut-out measurements

Best possible extraction performance

To ensure the best possible performance, piping of $\varnothing 200$ mm (IEC200) is recommended.

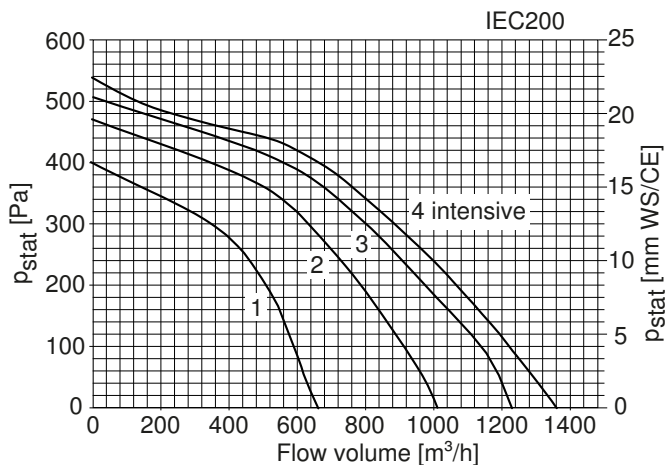

13 Dishwashers

13.1 General notes



It must be possible to pull the appliance out of the niche horizontally at any time without dismantling any part of the cabinet.

► Screws and fasteners must be countersunk in the niche. There should be no protruding parts, screw heads, brackets, etc., otherwise parts of the appliance could become damaged (risk of water damage).

⇒ Efficient repairs can only be guaranteed if it is possible to uninstall the whole appliance at any time without causing any damage.



It must be ensured air gap remains in the shadow gap.



General operating conditions

Ambient temperature: from min. 10 °C to max. 35 °C

The appliances are designed for use up to a max. altitude of 2,000 m above sea level.

Validity

Model designation	Type	Model number
AdoraDish V2000	AS2T	41162
AdoraDish V6000	AS6T	41147, 41171

Dishwashers with heat pump (see page 106)

13.2 Electrical connection data / Plumbing-in data

Connection example

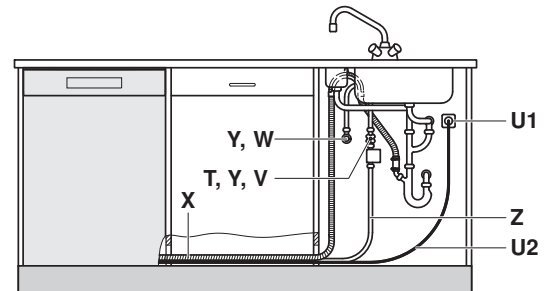
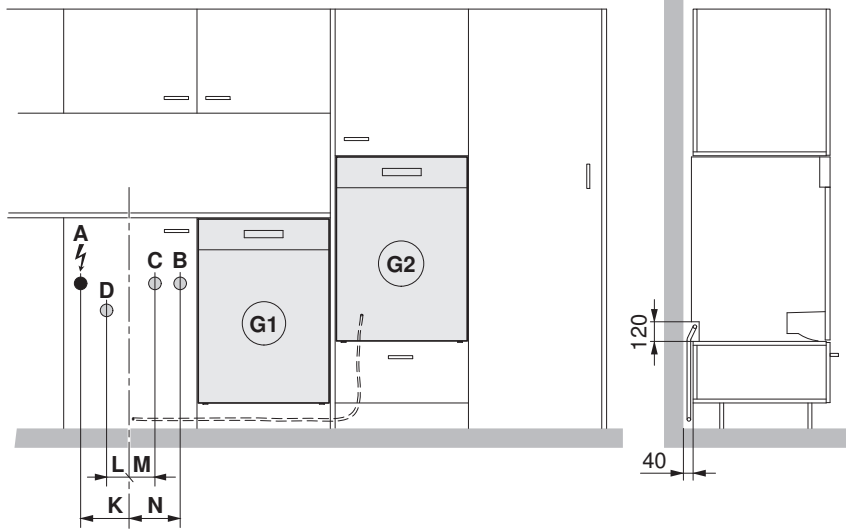

Designation		Connection from floor (plinth height 105 mm)	Connection in niche (from centre to connection)	Type of connection
A	Electrical connection	600 mm	K = 160 mm	Flush power socket 220–240 V
B	Cold water	600 mm	N = 170 mm	G ³ / ₄ "
C	Hot water *	600 mm	M = 70 mm	G ³ / ₄ "
D	Drain	400 mm	L = 110 mm	ø56 mm
G1	Dishwasher in base unit	Connection in adjacent compartment left or right		
G2	Dishwasher in tall unit	Connection in max. 2 compartments left or right		
T	Backflow preventer	Yes, 3/4"		
U1	Power socket	Yes		
U2	Connection cable	Length 1.50 m **		
V	Cold water connection	Yes		
W	Hot water connection *	Yes		
X	Drain hose	Length 1.55 m ** / internal diameter = 22 mm		
Y	Shut-off devices	Yes, 3/4"		
Z	Aquastop / water inlet with filter, G ³ / ₄ "	Length 1.55 m **		

* The hot water connection can be activated for a water flow temperature of at least 45 °C to maximum 60 °C. For the "No heating" function, a water flow temperature of 60 °C is recommended.

** If the standard connection length is not long enough, order the CS set with a longer connection length (AdoraDish (see page 144)).

Special lengths must be connected directly to the appliance.
Conversion (AdoraDish (see page 144)) at a later point in time must be carried out by qualified personnel.

Electrical connection data



General information on the electrical connections and an overview of the positions can be found in section Overview of connections, ranges and dimensions (see page 5).

Model designation	Type	Model number	Rated load	Mains connection	Fuse	Mains cable
AdoraDish V6000	AS6T	41118, 41120	2200 W	220–240 V~ 50 Hz	10 A	1.5 m, with plug
AdoraDish V2000	AS2T	41108	2200 W	220–240 V~ 50 Hz	10 A	

Plumbing-in data



For special cases with water hardness in excess of 50 °fH, an external water softener is recommended.



Due to a standards requirement, the appliances must be connected to the drinking water supply by means of the backflow preventer (1278183) supplied.

Value		Nominal value	Minimum	Maximum
Mains pressure (0.1 MPa = 1 bar)	Static	0.3–0.4 MPa	0.1 MPa	1.0 MPa
	Flowing	–	0.08 MPa	1.0 MPa
Water hardness		–	0.5 °fH	50 °fH
Water inlet temperature		–	5 °C	60 °C



13.3 Installation overview

Depending on niche height **H**, either standard or extra height appliances or only one of the two can be installed.

Niche height **H** in mm

	790	800	810	820	830	840	851	860	870	880	890	900	910	920	930	940	950	960
250												S						G
240											S	S					G	G
230										S	S	S				G	G	G
220									S	S	S	S			G	G	G	G
210								S	S	S	S	S		G	G	G	G	G
200							S	S	S	S	S	S	G	G	G	G	G	G
190						S	S	S	S	S	S	S/G	G	G	G	G	G	G
180					S	S	S	S	S	S	S/G	S/G	G	G	G	G	G	G
170				S	S	S	S	S	S	S/G	S/G	S/G	G	G	G	G	G	G
160			S	S	S	S	S	S	S/G	S/G	S/G	S/G	G	G	G	G	G	G
150		S	S	S	S	S	S	S/G	S/G	S/G	S/G	S/G	G	G	G	G	G	G
140	S	S	S	S	S	S	S/G	S/G	S/G	S/G	S/G	S/G	G	G	G	G	G	G
130	S	S	S	S	S	S	S/G	S/G	S/G	S/G	S/G	S/G	G	G	G	G	G	G
120	S	S	S	S	S	S	S/G	S/G	S/G	S/G	G	G	G	G	G	G		
110	S	S	S	S	S	S	S/G	S/G	S/G	G	G	G	G	G	G			
107	S	S	S	S	S	S	S/G	S/G	S/G	G	G	G	G	G				
100	S	S	S	S	S	S	S/G	S/G	G	G	G	G	G	G				
90	S	S	S	S	S	S	S/G	G	G	G	G	G	G					
80	S	S	S	S	S	S	G	G	G	G	G	G						
70	S	S	S	S	S		G	G	G	G	G							
60	S	S	S	S			G	G	G	G								
50	S	S	S				G	G	G									
40	S	S					G	G										
30	S						G											
23							G											

- S Standard
- G Extra height
- S/G Standard and extra height

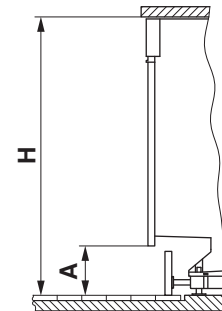

13.4 Drilling plans for decor panel 60 cm

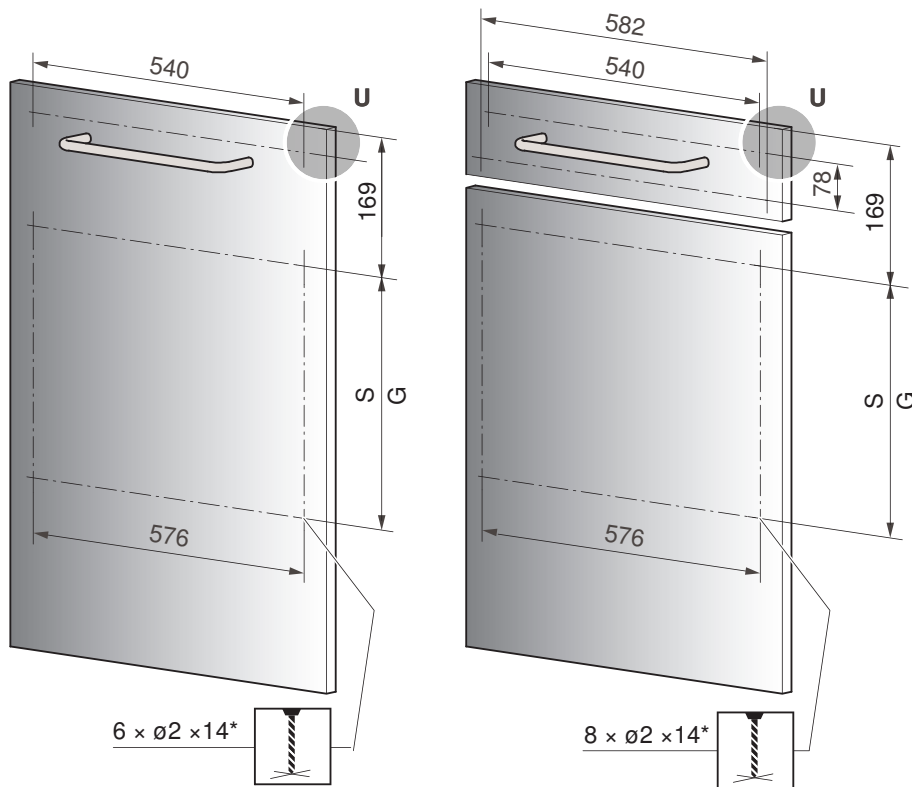

S = Standard height	G = Extra height	*
350 mm	415 mm	Depth drilled from the back

Detail U

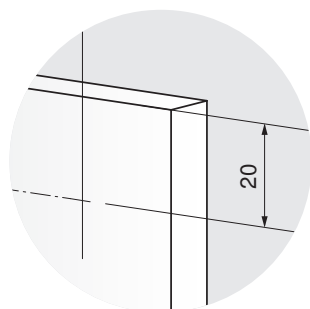

13.5 Dishwashers with niche width 60 cm



For worktops that are susceptible to moisture ingress, use worktop protection W70163.

Base unit «standard»

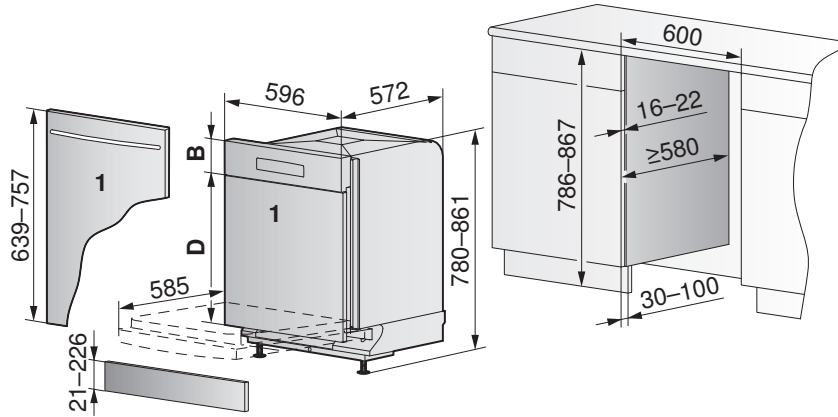

Appliance height		Niche height
780 - 825	2	786 - 831
816 - 861	3	822 - 867
851 - 896		857 - 902

The adjustable plinth 2 and the plinth runner 3 are included in the scope of delivery.

Additional plinth runners – to be ordered under Accessories.

► Front panel / decor system (wood) 1 must be cut to the required dimensions.



		Niche height H in mm												min. S in mm
		790	800	810	820	830	840	850	860	870	880	890	900	
Dimension A in mm ↑	min.	27	37	47	57	67	77	87	97	107	117	127	137	2
		37	47	57	67	77	87	97	107	117	127	137	147	2
		47	57	67	77	87	97	107	117	127	137	147	157	2
		57	67	77	87	97	107	117	127	137	147	157	167	2
		67	77	87	97	107	117	127	137	147	157	167	177	2
		77	87	97	107	117	127	137	147	157	167	177	187	2
		87	97	107	117	127	137	147	157	167	177	187	197	2
		97	107	117	127	137	147	157	167	177	187	197	207	2
		107	117	127	137	147	157	167	177	187	197	207	217	5
		117	127	137	147	157	167	177	187	197	207	217	227	10
		127	137	147	157	167	177	187	197	207	217	227	237	15
		137	147	155	167	177	187	197	207	217	227	237	247	23
	max.		145	155	165	175	185	195	205	215	225	235	245	255

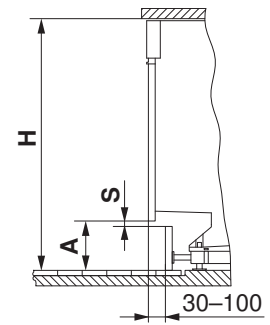

The permissible weights of the front panel / decor panel system 1 depend on the design variant:

Spring	Decor system
	Fully integrated
Grade 0 white	2 to 6 kg
Grade 1 blue	4 to 8.5 kg *
Grade 2 yellow **	7.5 to 12.5 kg **
Grade 3 green **	12.5 to 17.5 kg

* These springs are fitted as standard ex works.

** These spring variants are available as accessories.

All spring variants are available as spare parts.





The weight specifications apply to uniform decor panels up to 22 mm thick.

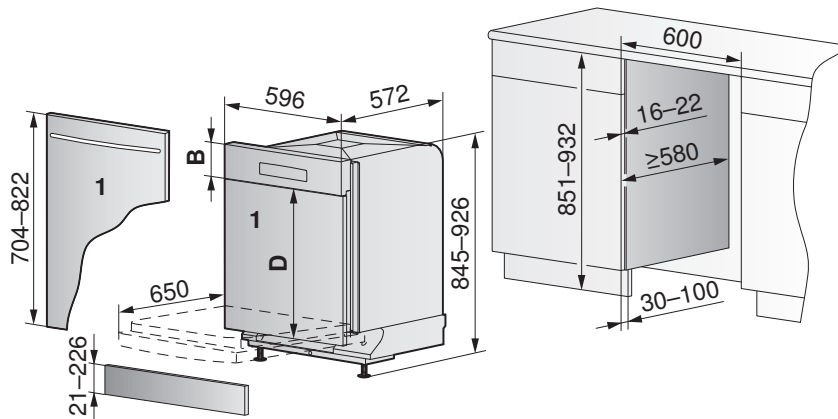

For extra-long, uneven (e.g. frame constructions or bevelled glass plates, etc.) or thick (> 22 mm) decor panels, use the calculation tool (https://www.vzug.com/b2b/de/de/b2b_planningaid_page) to determine suitable springs.

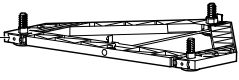
Base unit «extra height»



Appliance height		Niche height
845 - 890	2 	851 - 896
881 - 926	3 	887 - 932
916 - 961	 	922 - 967

The adjustable plinth **2** and the plinth runner **3** are included in the scope of delivery.

Additional plinth runners  – to be ordered under Accessories.

► Front panel / decor system (wood) **1** must be cut to the required dimensions.



		Niche height H in mm												min. S in mm	
Dimension A in mm ↑	min.	23	32	42	52	62	72	82	92	102	112	122	132	2	
		33	42	52	62	72	82	92	102	112	122	132	142	2	
		43	52	62	72	82	92	102	112	122	132	142	152	2	
		53	62	72	82	92	102	112	122	132	142	152	162	2	
		63	72	82	92	102	112	122	132	142	152	162	172	2	
		73	82	92	102	112	122	132	142	152	162	172	182	2	
		83	92	102	112	122	132	142	152	162	172	182	192	2	
		93	102	112	122	132	142	152	162	172	182	192	202	2	
		103	112	122	132	142	152	162	172	182	192	202	212	5	
		113	122	132	142	152	162	172	182	192	202	212	222	10	
		123	132	142	152	162	172	182	192	202	212	222	232	15	
		133	142	152	162	172	182	192	202	212	222	232	242	23	
	max.		141	150	160	170	180	190	200	210	220	230	240	250	30

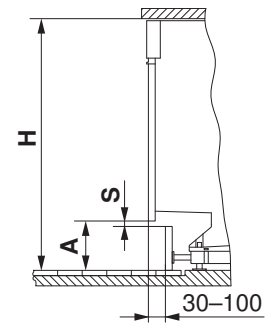

The permissible weights of the front panel / decor panel system 1 depend on the design variant:

Spring	Decor system
	Fully integrated
Grade 1 blue	2 to 5.5 kg
Grade 2 yellow **	4.5 to 8.5 kg *
Grade 3 green **	8.5 to 12.5 kg **
Grade 4 red **	12.5 to 16 kg

* These springs are fitted as standard ex works.

** These spring variants are available as accessories.

All spring variants are available as spare parts.

The weight specifications apply to uniform decor panels up to 22 mm thick.



For extra-long, uneven (e.g. frame constructions or bevelled glass plates, etc.) or thick (> 22 mm) decor panels, use the calculation tool (https://www.vzug.com/b2b/de/de/b2b_planningaid_page) to determine suitable springs.

Tall unit «standard»

Can also be installed in base unit on plinth

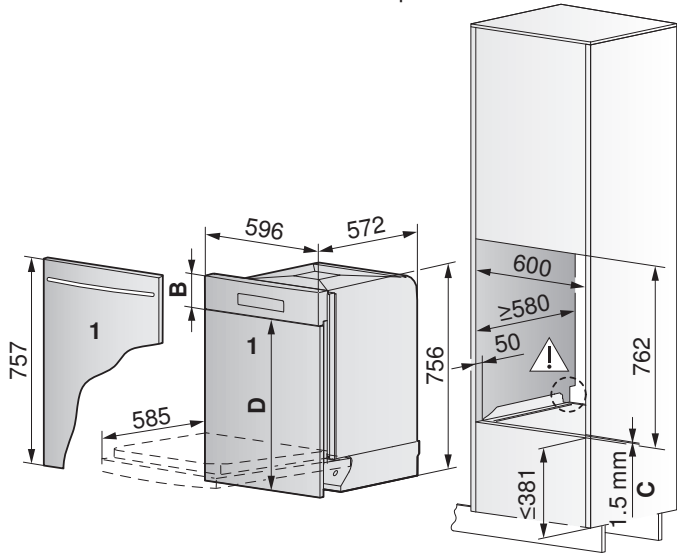

Tall unit «extra height»

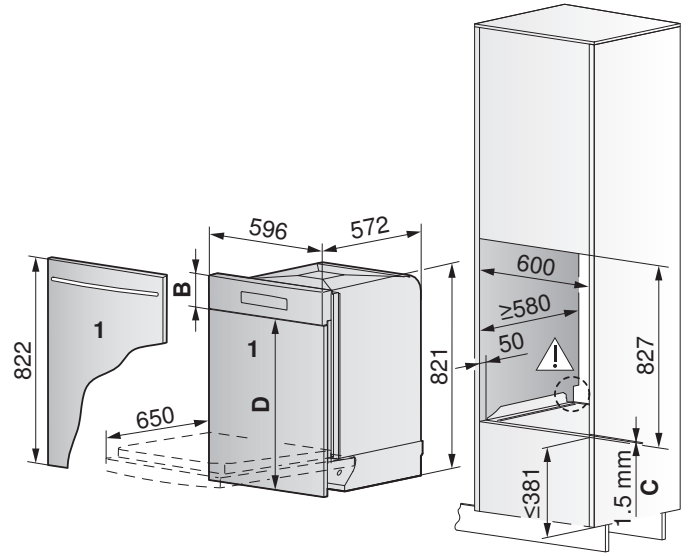

C Slide plate *

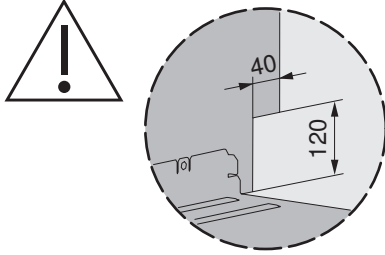

* Slide plate conversion set for tall unit must be ordered from V-ZUG, see Accessories (see page 144).

Tall unit «extra height» with decor panel and drawer 251 mm

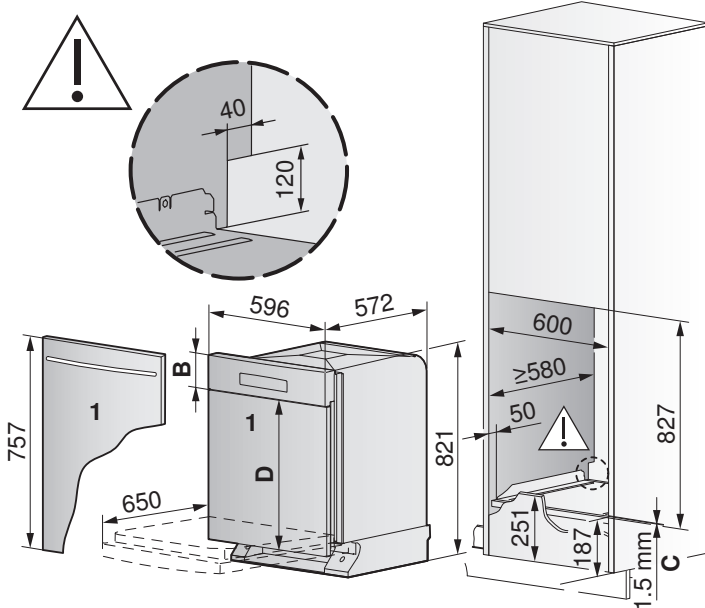

Cross-section of installation variant

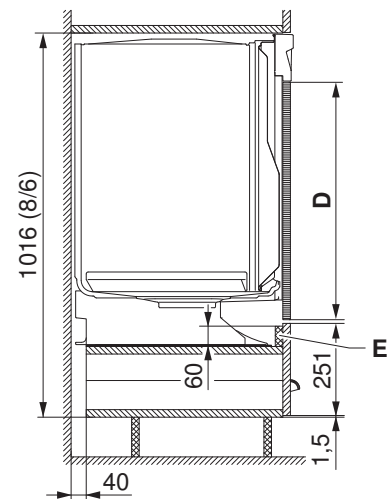

C Slide plate *

E Removable cover strip

* Slide plate conversion set for tall unit must be ordered from V-ZUG, see Accessories (see page 144).

Installing extra-long decor panel

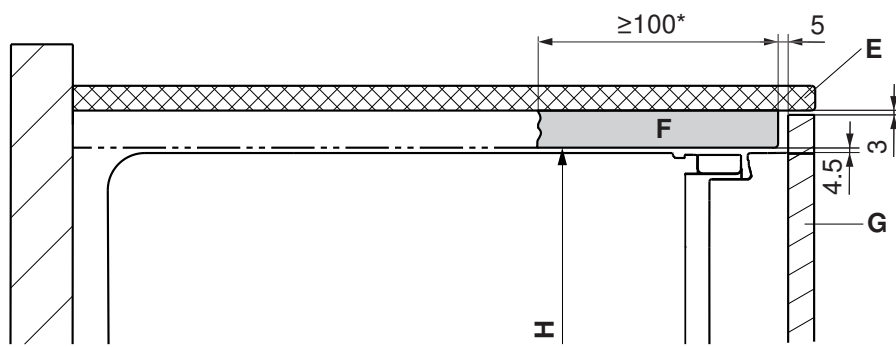

* A continuous soffit vent is recommended.

- E** Worktop
- F** Continuous soffit vent
- G** Decor panel
- H** Niche height

14 Dishwashers with heat pump

14.1 General notes



It must be possible to pull the appliance out of the niche horizontally at any time without dismantling any part of the cabinet.

- ▶ Screws and fasteners must be countersunk in the niche. There should be no protruding parts, screw heads, brackets, etc., otherwise parts of the appliance could become damaged (risk of water damage).
- ⇒ Efficient repairs can only be guaranteed if it is possible to uninstall the whole appliance at any time without causing any damage.



It must be ensured air gap remains in the shadow gap.



General operating conditions

Ambient temperature: from min. 10 °C to max. 35 °C

The appliances are designed for use up to a max. altitude of 2,000 m above sea level.

Validity

Model designation	Type	Model number
AdoraDish V6000	AS6T	41173

14.2 Electrical connection data / Plumbing-in data

Connection example

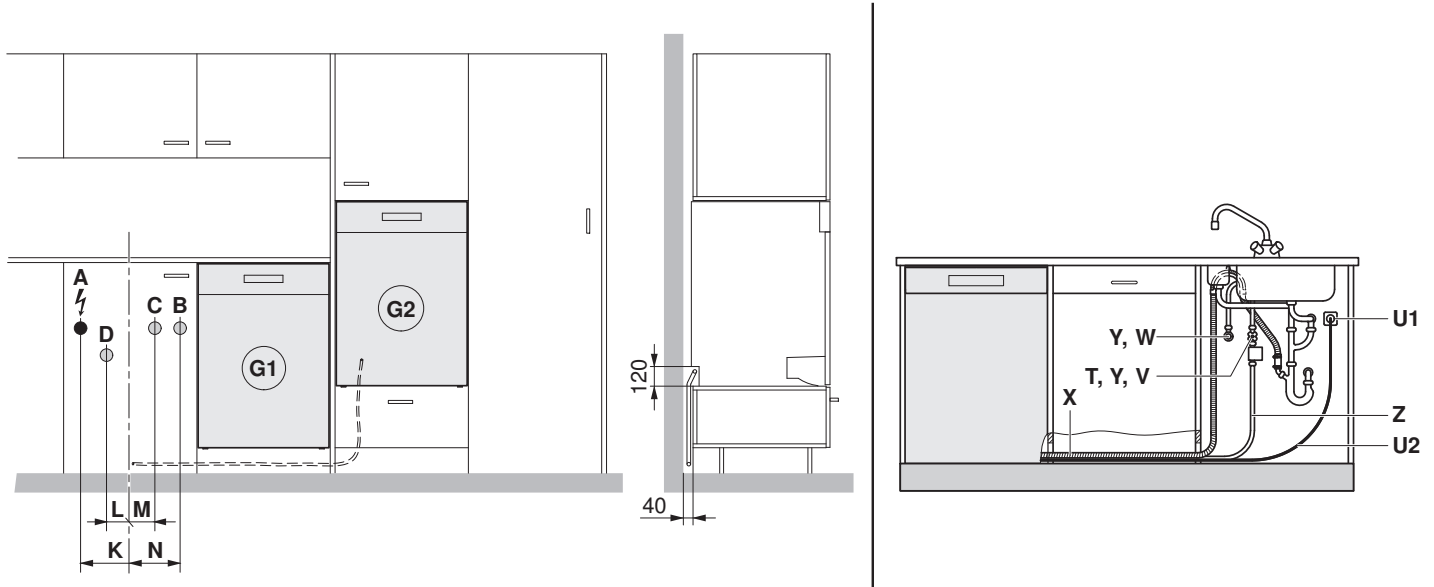

Designation		Connection from floor (plinth height 105 mm)	Connection in niche (from centre to connection)	Type of connection
A	Electrical connection	600 mm	K = 160 mm	Flush power socket 220–240 V
B	Cold water	600 mm	N = 170 mm	G ³ / ₄ "
C	Hot water *	600 mm	M = 70 mm	G ³ / ₄ "
D	Drain	400 mm	L = 110 mm	ø56 mm
G1	Dishwasher in base unit	Connection in adjacent compartment left or right		
G2	Dishwasher in tall unit	Connection in max. 2 compartments left or right		
T	Backflow preventer	Yes, 3/4"		
U1	Power socket	Yes		
U2	Connection cable	Length 1.50 m **		
V	Cold water connection	Yes		
W	Hot water connection *	Yes		
X	Drain hose	Length 1.55 m ** / internal diameter = 22 mm		
Y	Shut-off devices	Yes, 3/4"		
Z	Aquastop / water inlet with filter, G ³ / ₄ "	Length 1.55 m **		

* The hot water connection can be activated for a water flow temperature of at least 45 °C to maximum 60 °C. For the “No heating” function, a water flow temperature of 60 °C is recommended.

** If the standard connection length is not long enough, order the CS set with a longer connection length (AdoraDish (see page 144)).



Special lengths must be connected directly to the appliance. Conversion (AdoraDish (see page 144)) at a later point in time must be carried out by qualified personnel.

Electrical connection data



General information on the electrical connections and an overview of the positions can be found in section Overview of connections, ranges and dimensions (see page 5).

Model designation	Type	Model number	Rated load	Mains connection	Fuse	Mains cable
AdoraDish V6000	AS6T	41121	2200 W	220–240 V~ 50 Hz	10 A	1.5 m, with plug

Plumbing-in data



For special cases with water hardness in excess of 50 °fH, an external water softener is recommended.



Due to a standards requirement, the appliances must be connected to the drinking water supply by means of the backflow preventer (1278183) supplied.

Value		Nominal value	Minimum	Maximum
Mains pressure (0.1 MPa = 1 bar)	Static	0.3–0.4 MPa	0.1 MPa	1.0 MPa
	Flowing	–	0.08 MPa	1.0 MPa
Water hardness		–	0.5 °fH	50 °fH
Water inlet temperature		–	5 °C	60 °C

14.3 Installation overview



Keep base compartment unobstructed, appliance stands on the floor.

		Niche height H in mm				
		870	880	890	900	910
Dimension A in mm	200					S
	190				S	S
	180			S	S	S
	170		S	S	S	S
	160	S	S	S	S	S
	150	S	S	S	S	S
	140	S	S	S	S	
	130	S	S	S		
	120	S	S			
	110	S				
105	S					

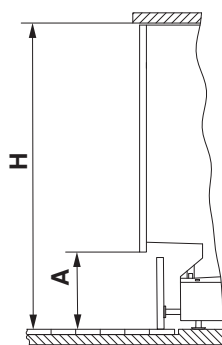

S Standard without unit base

14.4 Drilling plans for decor panel 60 cm

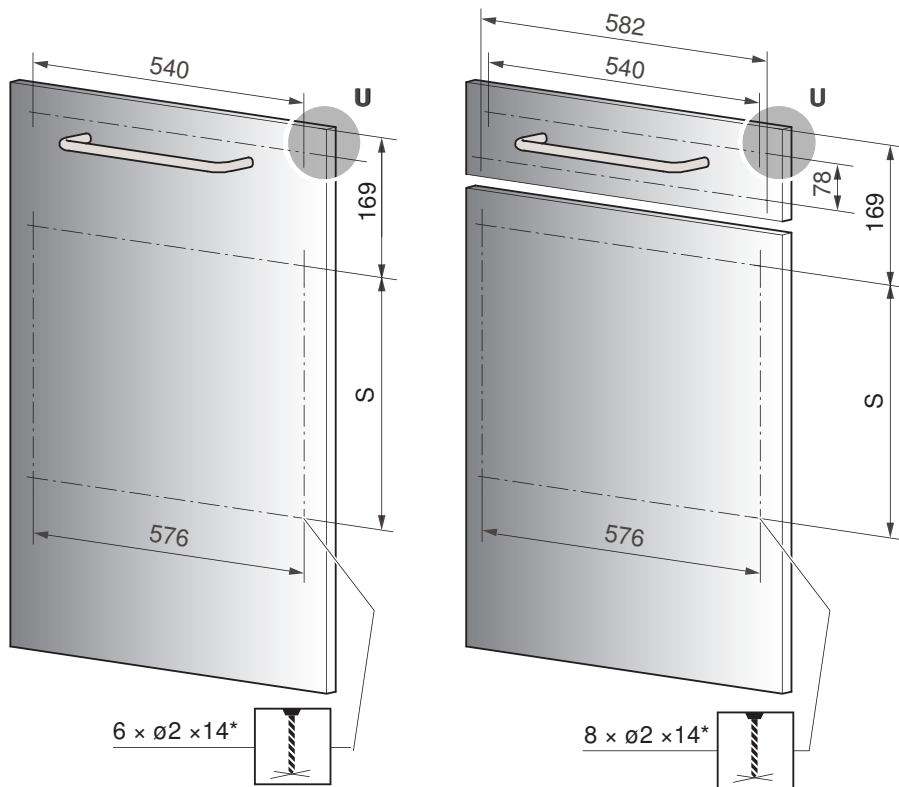

S = Standard height	*
350 mm	Depth drilled from the back

Detail U

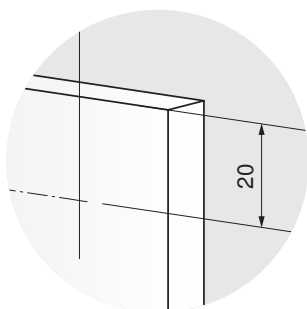

14.5 Dishwashers with niche width 60 cm



For worktops that are susceptible to moisture ingress, use worktop protection W70163.

Base unit

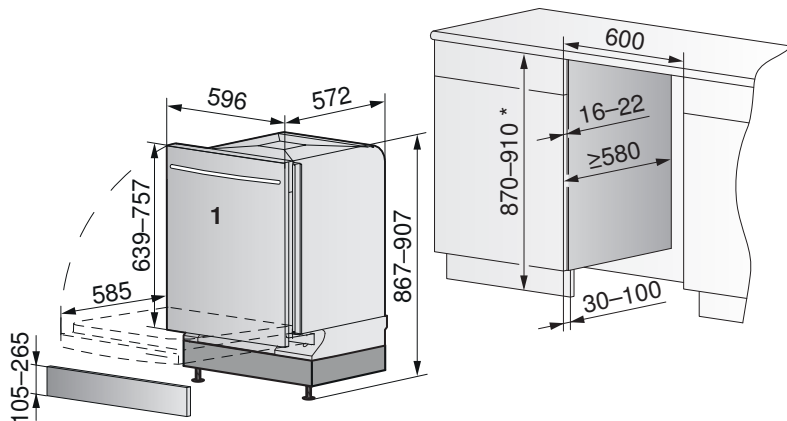

* If the niche height is greater than 910 mm, a plate must be placed underneath the appliance or an extra-long decor panel must be used.

► Front panel / decor system (wood) 1 must be cut to the required dimensions.

Dimension A in mm	Niche height H in mm					min. S in mm
	870	880	890	900	910	
min.	107	117	127	137	147	2
	117	127	137	147	157	2
	127	137	147	157	167	2
	137	147	157	167	177	2
	147	157	167	177	187	2
	157	167	177	187	197	2
	167	177	187	197	207	2
	177	187	197	207	217	2
	187	197	207	217	227	5
	197	207	217	227	237	10
	207	217	227	237	247	15
max.	217	227	237	247	257	23
	225	235	245	255	265	30

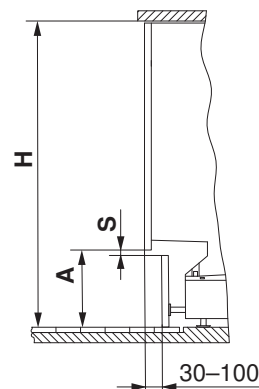

Decor system	Fully integrated
Standard springs (grade 1 blue)	2.5 to 6 kg
Reinforced springs (grade 2 yellow)*	6 to 9.5 kg
Reinforced springs (grade 3 green)	9.5 to 13.5 kg

The weight specifications apply to uniform decor panels up to 22 mm thick.



For extra-long, uneven (e.g. frame constructions or bevelled glass plates, etc.) or thick (> 22 mm) decor panels, use the calculation tool (https://www.vzug.com/b2b/de/de/b2b_planningaid_page) to determine suitable springs.

Tall unit

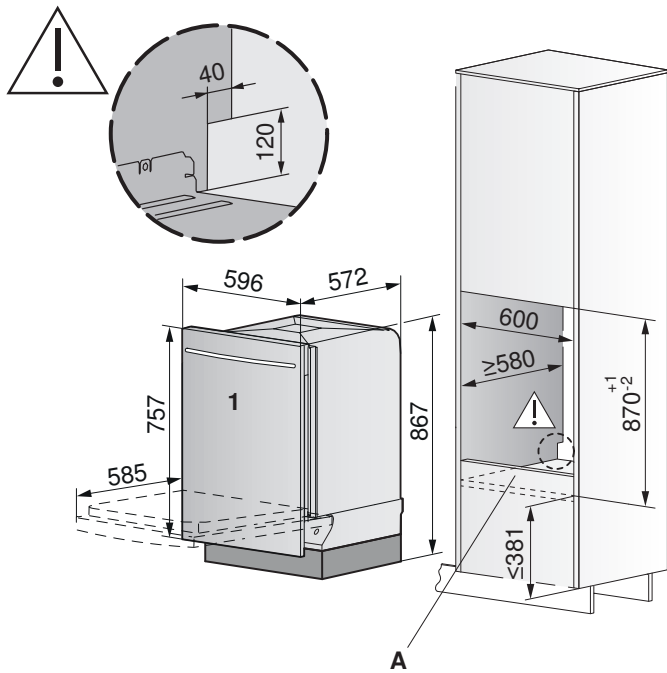

Cross-section of installation example

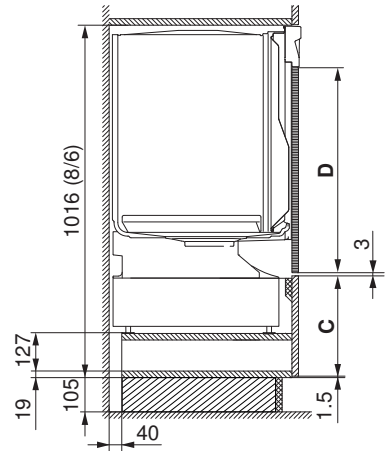

C Removable lower front panel (251)

Niche floor A

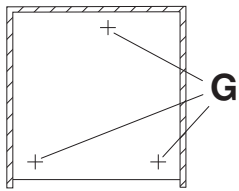

- Load-bearing capacity of niche floor A: 100 kg
- Given a load of 75 kg per appliance foot G, the niche floor may sag by a max. of 1 mm.

Installing extra-long decor panel

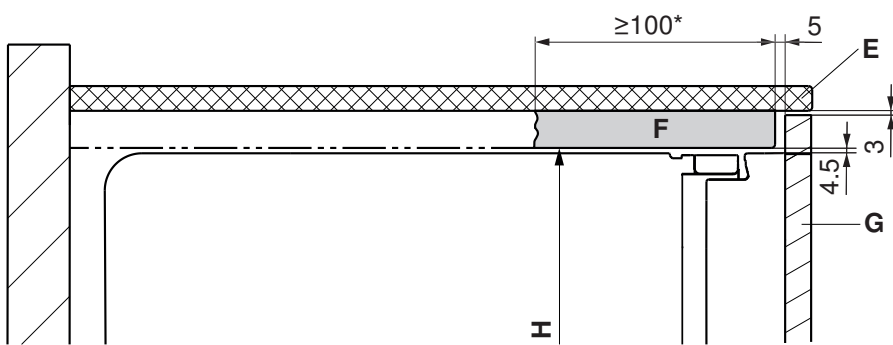

* A continuous soffit vent is recommended.

- E Worktop
- F Continuous soffit vent
- G Decor panel
- H Niche height

15 Refrigerating and freezing appliances

15.1 General notes



Insufficient ventilation can cause a malfunction and shorten the service life of the appliance.

Heavy door panel weights shorten the service life of the door hinges. Observe maximum permissible weight for door panel.

Efficient repairs can only be guaranteed if it is possible to uninstall the whole appliance at any time without causing any damage.

In an open-plan kitchen and living room, higher noise emissions can be expected if the ventilation slits face into the room.

15.2 Electrical connection data

Type of appliance	Climate class	Mains connection	Fuse	Mains cable
Refrigerators				
CombiCooler V6000 178NI (51149)	SN-T	220–240 V~ 50 Hz	10 A	2.2 m, with plug
CombiCooler V4000 178NI (51151)	SN-T			
CombiCooler V6000 75 Supreme (51115)	SN-T			2.5 m, with plug
Cooler V6000 75 Supreme (51116)	SN-T			
CombiCooler V6000 90 Supreme (51133)	SN-T			
Cooler V6000 90 Supreme (51134)	SN-T			
Cooler V4000 178K (51140)	SN-T			2.2 m, with plug
Winecoolers				
WineCooler V6000 60 Supreme (51154)	SN-T	220–240 V~ 50 Hz	10 A	2.5 m, with plug
WineCooler V4000 90 (51102)	SN-T			2.2 m, with plug
WineCooler V4000 45 (51113)	SN-T			
Freezers				
Freezer V6000 60 Supreme (53006)	SN-T	220–240 V~ 50 Hz	10 A	2.5 m, with plug
Freezer V4000 178N (53009)	SN-T			2.2 m, with plug

15.3 Ambient conditions



**Condensate may form on the appliance in tropical conditions.
This has to be taken into account in the planning.**

Room temperature

Climate class	Minimum	Maximum
SN	+10 °C	+32 °C
N	+16 °C	+32 °C
ST	+16 °C	+38 °C
T	+16 °C	+43 °C
SN-ST	+10 °C	+38 °C
SN-T	+10 °C	+43 °C

Maximum installation/operating altitude above sea level



All refrigerating and freezing appliances: up to a max. altitude of 2,000 m above sea level.

Exceptions: WineCooler V4000 90 (51102), WineCooler V4000 45 (51113), WineCooler V6000 (51135). These appliances are designed for use up to a max. altitude of 1,500 m above sea level.

15.4 Niche ventilation

For trouble-free heat dissipation of the appliance, an air duct must be provided whose width is no greater than the width of the unit with an unobstructed passage of at least 200 cm² from the air inlet in the plinth area **A** to the air outlet at the back **B** and at the front at the top **C**.

If there are wall units the ventilation gap **x** must be selected according to the following table.

If, for design reasons, a smaller ventilation gap **y** is preferred for the front-facing air outlet at the top, then ventilation at the top must be possible across several unit widths. The dimensions for **y** are given in the following table.

If refrigerators/freezers are installed side by side, the cross-section requirements for the air duct are doubled (**width b**).

Dimensions per appliance	b (mm)	y (mm)	x (mm)	
	550–568	≥40	≥50	
	1100–1168	≥30	≥100	
	≥1650	≥20		

15.5 Refrigerators

CombiCooler V6000 178NI (51149)

(integrable)

Maximum permissible weight of door panel: 17.5 kg (top) / 12 kg (bottom)

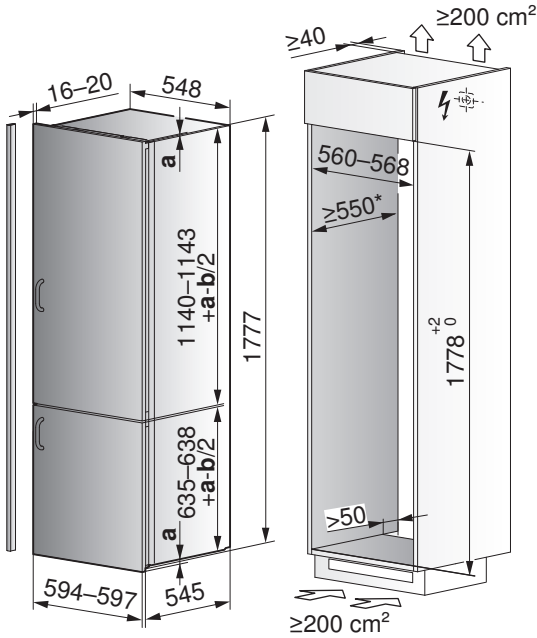

a Overlap, b Gap (≥4 mm)

CombiCooler V4000 178NI (51151)

(integrable)

Maximum permissible weight of door panel: 17.5 kg (top) / 12 kg (bottom)

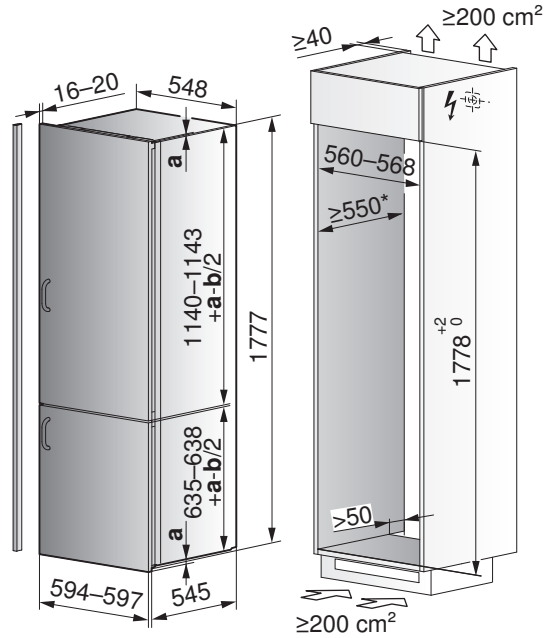

* = Recommendation: 560 mm.

Cooler V4000 178K (51140)

(integrable)

Maximum permissible weight of door panel: 26 kg

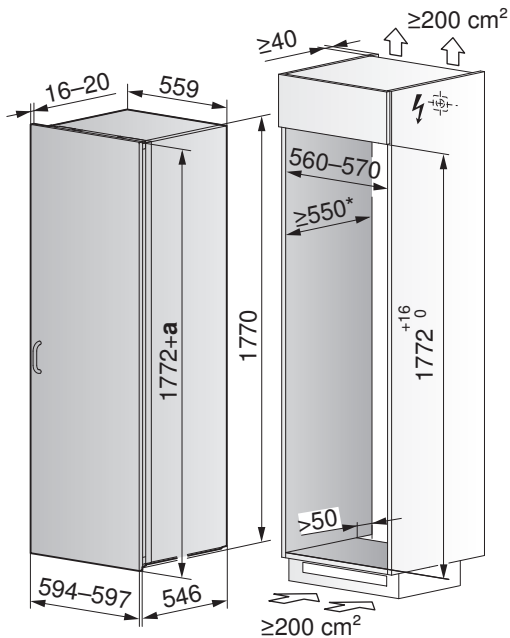

a Overlap, * = Recommendation: 560 mm.

CombiCooler V6000 75 Supreme (51115)
CCO7205NBTMVI (fully integrable)

Gross weight: ~190 kg. Maximum permissible weight of door panel: 23 kg (top) / 11 kg (bottom). Water connection: Length 2.5 m, complies with EN 61770. Fixed water connection : 3/4" internal thread, inlet pressure from 0.05 MPa to 0.5 MPa (0.5 bar to 5 bar). The water connection must be accessible at all times. Electrical connection cable: 2.5 m.

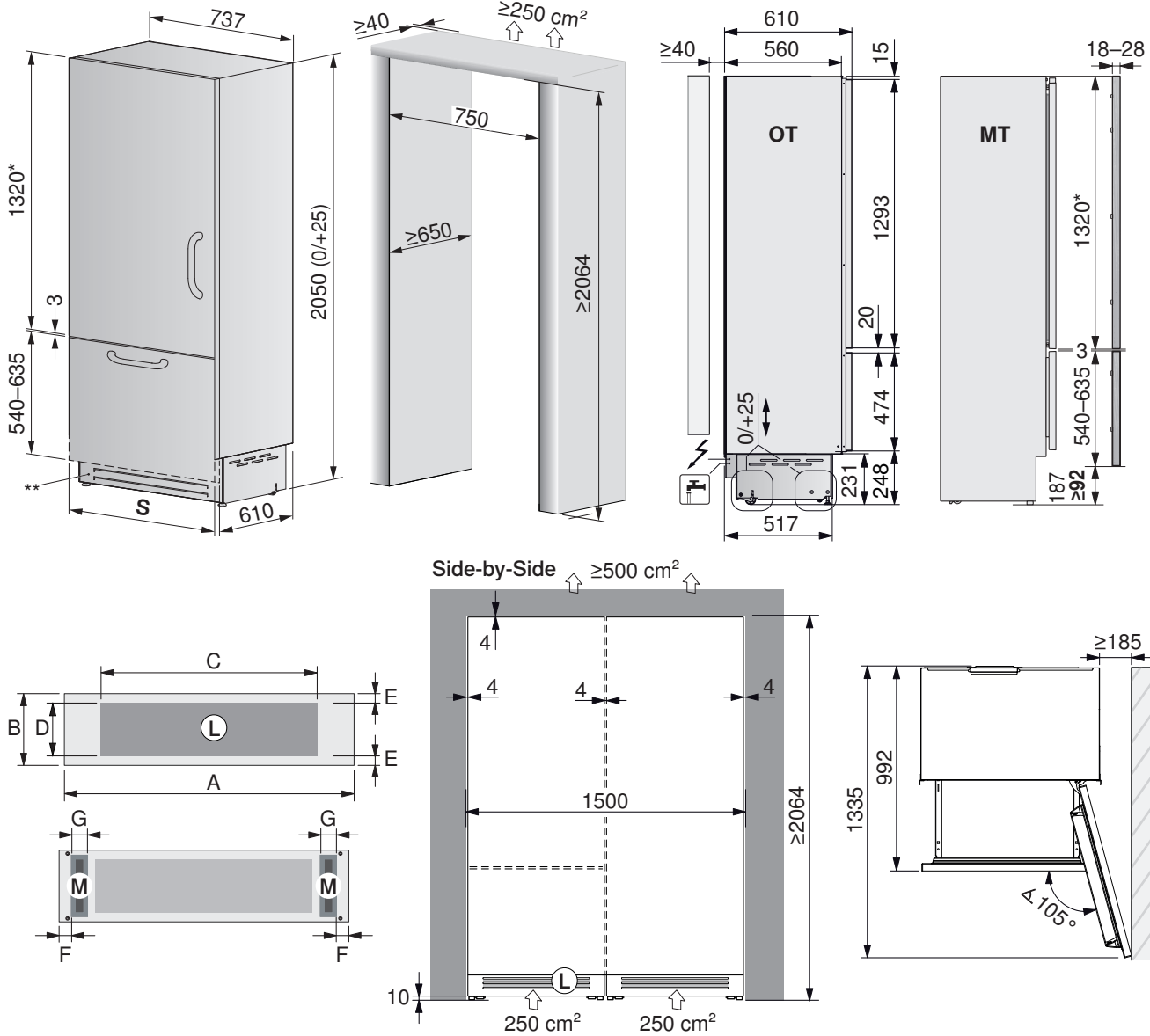

* = For niche height >2064, the height of door panel must be adjusted.

** = Chrome front grille can be replaced by kitchen cabinet front (for dimensions see installation instructions).

S Solo installation: Width of cabinet front 744 mm, dimension of gap 3 mm, **Side-by-side:** Width of cabinet front 744 mm, dimension of gap 4 mm

OT View without door panel, **MT** View with door panel, **L** Air inlet (at least 50% open), **M** Magnet for mounting.

Dimensions for ventilation grille and position of magnet:

A = 744, **B** = 215, **C** = 550, **D** = 200, **E** = approx. 10, **F** = 60, **G** = 15–30.

Installation accessories: Chrome steel door panel set (incl. pearl door handle) width: 744, height of refrigerating section: 1320, height of freezer section: 580. Hinge left: Article no. **1281229**, hinge right: Article no. **1281228**. For side-by-side installation: Lateral plastic connecting angle, plastic cover strip and intermediate plastic cover strip are included in the scope of delivery.

Cooler V6000 75 Supreme (51116)

CO7205TVI (fully integrable)

Gross weight: 175 kg. Maximum permissible weight of door panel: 34 kg.

Electrical connection cable: 2.5 m.

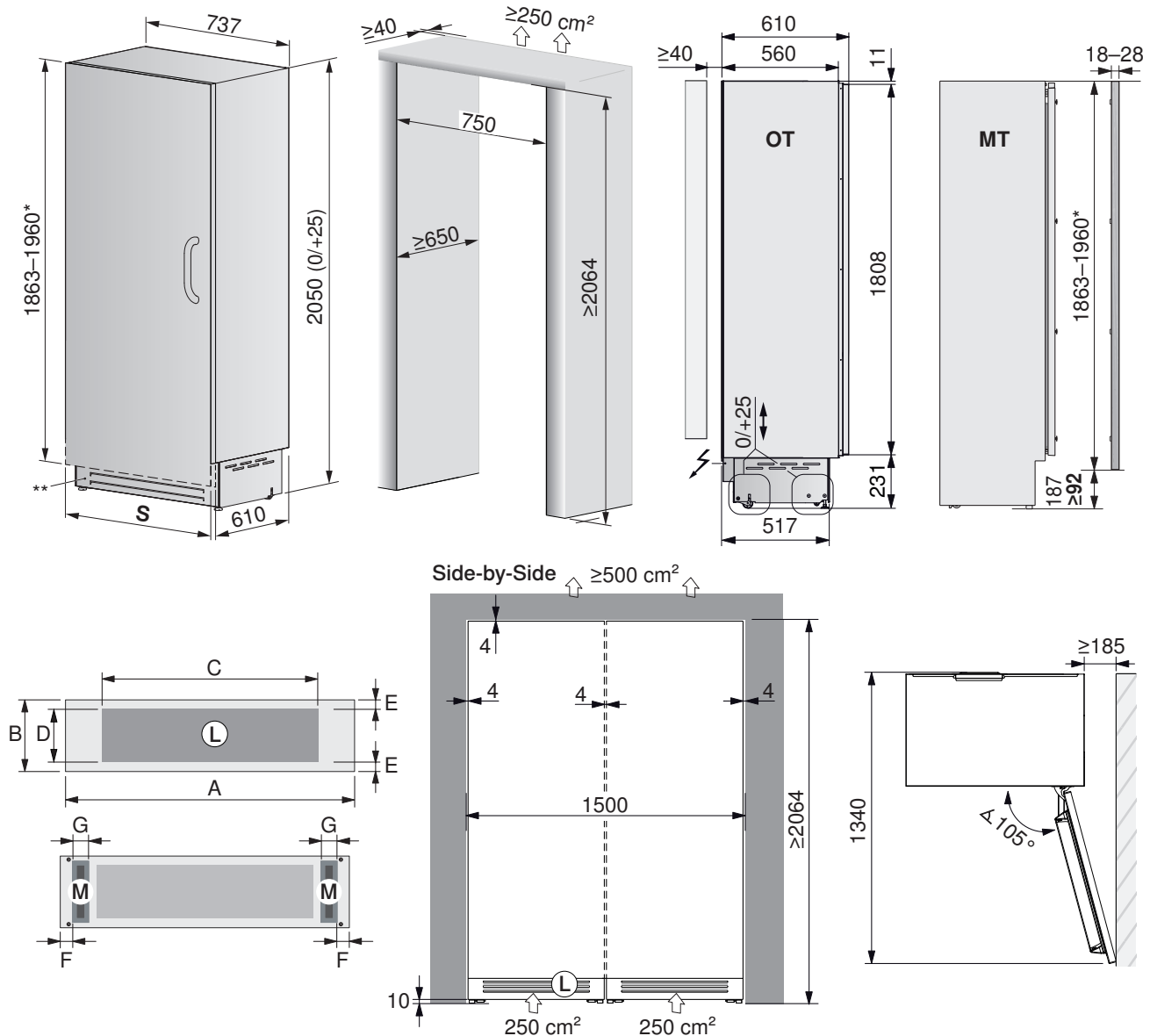

* = For niche height >2064, drill holes in and height of door panel must be adjusted (see installation instructions).

** = Chrome front grille can be replaced by kitchen cabinet front (for dimensions see installation instructions).

S Solo installation: Width of cabinet front 744 mm, dimension of gap 3 mm, **Side-by-side:** Width of cabinet front 744 mm, dimension of gap 4 mm

OT View without door panel, **MT** View with door panel, **L** Air inlet (at least 50% open), **M** Magnet for mounting.

Dimensions for ventilation grille and position of magnet:

A = 744, **B** = 215, **C** = 550, **D** = 200, **E** = approx. 10, **F** = 60, **G** = 15–30.

Installation accessories: Chrome steel door panel set (incl. pearl door handle) width: 894, height: 1904. Hinge left: Article no. **1090120**, hinge right: Article no. **1087157**. For side-by-side installation: Lateral plastic connecting angle, plastic cover strip and intermediate plastic cover strip are included in the scope of delivery.

CombiCooler V6000 90 Supreme (51133)
CCO9205NBHVI (fully integrable)

Gross weight: 212 kg. Maximum permissible weight of door panel: 23 kg (top) / 11 kg (bottom). Water connection: Length 2.5 m, complies with EN 61770. Fixed water connection : 3/4" internal thread, inlet pressure from 0.05 MPa to 0.5 MPa (0.5 bar to 5 bar). The water connection must be accessible at all times. Electrical connection cable: 2.5 m.

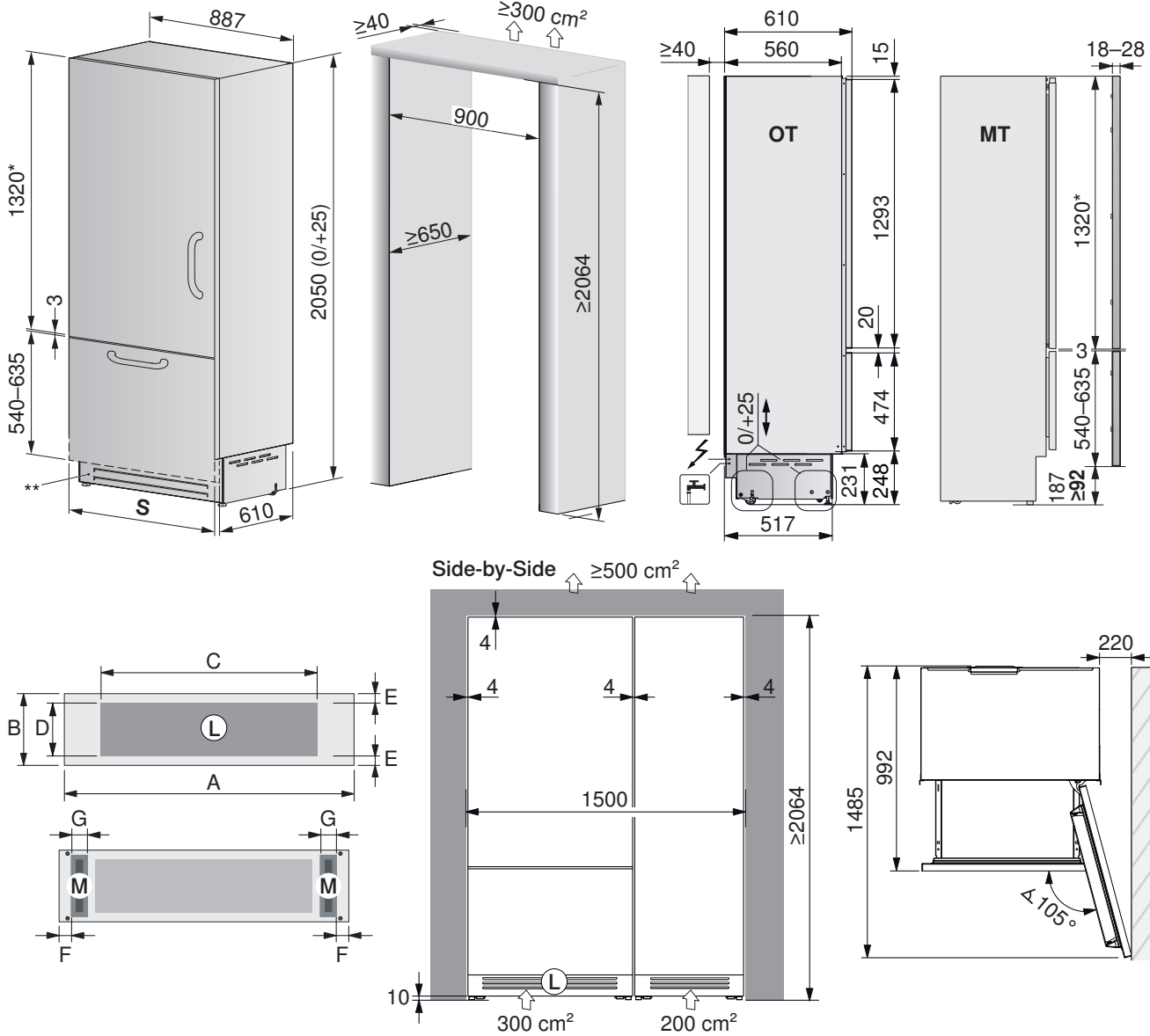

* = For niche height >2064, the height of door panel must be adjusted.

** = Chrome front grille can be replaced by kitchen cabinet front (for dimensions see installation instructions).

S Solo installation: Width of cabinet front 894 mm, dimension of gap 3 mm, **Side-by-side:** Width of cabinet front 894 mm, dimension of gap 4 mm

OT View without door panel, **MT** View with door panel, **L** Air inlet (at least 50% open), **M** Magnet for mounting.

Dimensions for ventilation grille and position of magnet:

A = 894, **B** = 215, **C** = 700, **D** = 200, **E** = approx. 10, **F** = 60, **G** = 15–30.

Installation accessories: Chrome steel door panel set (incl. pearl door handle) width: 894, height of refrigerating section: 1320, height of freezer section: 581. Hinge left: Article no. **1090119**, hinge right: Article no. **1087155**. For side-by-side installation: Lateral plastic connecting angle, plastic cover strip and intermediate plastic cover strip are included in the scope of delivery.

Cooler V6000 90 Supreme (51134)

CO9205H3VI (fully integrable)

Gross weight: 189 kg. Maximum permissible weight of door panel: 34 kg.

Electrical connection cable: 2.5 m.

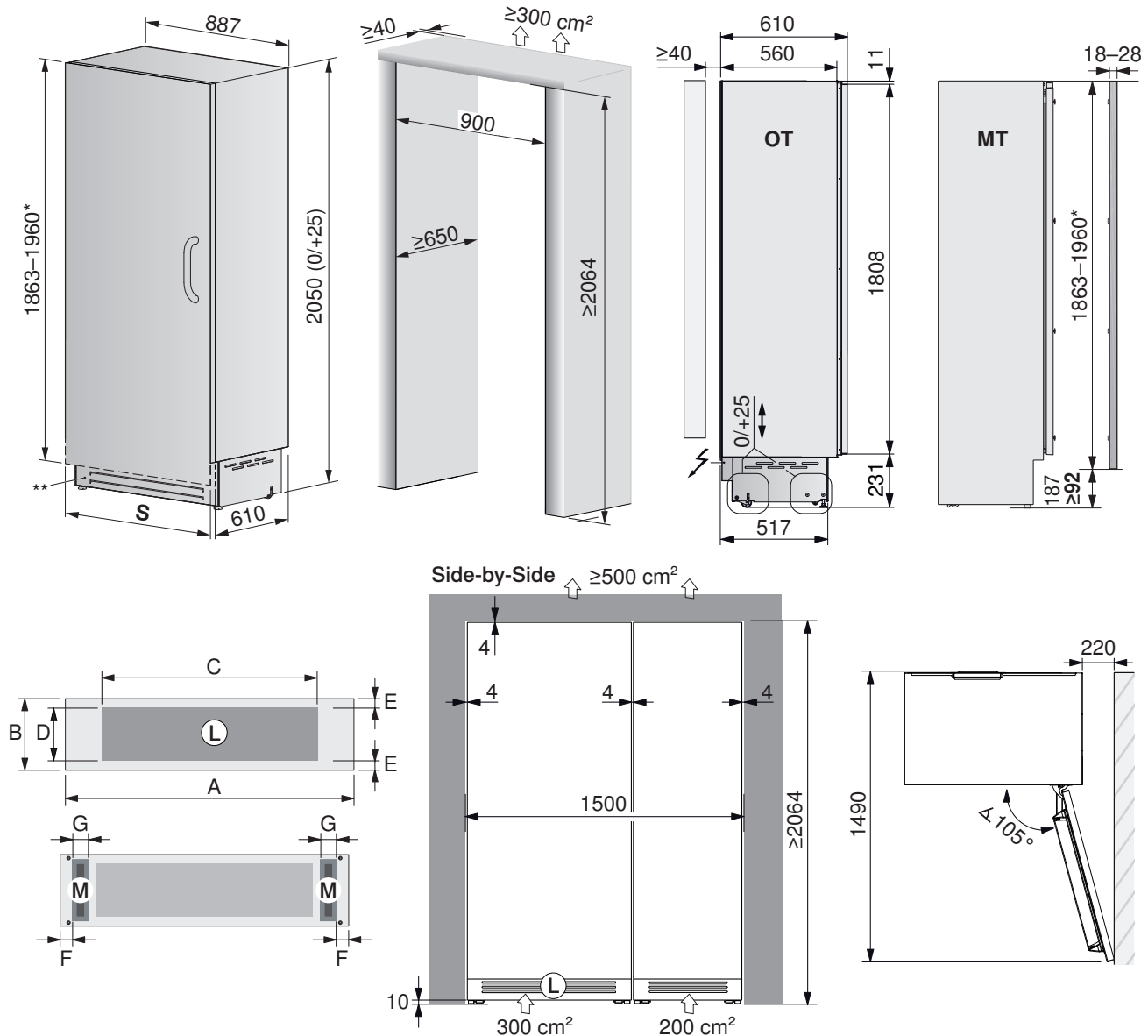

* = For niche height >2064, drill holes in and height of door panel must be adjusted (see installation instructions).

** = Chrome front grille can be replaced by kitchen cabinet front (for dimensions see installation instructions).

S Solo installation: Width of cabinet front 894 mm, dimension of gap 3 mm, **Side-by-side:** Width of cabinet front 894 mm, dimension of gap 4 mm

OT View without door panel, MT View with door panel, L Air inlet (at least 50% open), **M Magnet for mounting.**

Dimensions for ventilation grille and position of magnet:

A = 894, **B** = 215, **C** = 700, **D** = 200, **E** = approx. 10, **F** = 60, **G** = 15-30.

Installation accessories: Chrome steel door panel set (incl. pearl door handle) width: 894, height: 1904. Hinge left: Article no. **1090120**, hinge right: Article no. **1087157**. For side-by-side installation: Lateral plastic connecting angle, plastic cover strip and intermediate plastic cover strip are included in the scope of delivery.

15.6 Winecoolers

WineCooler V4000 90 (51102)

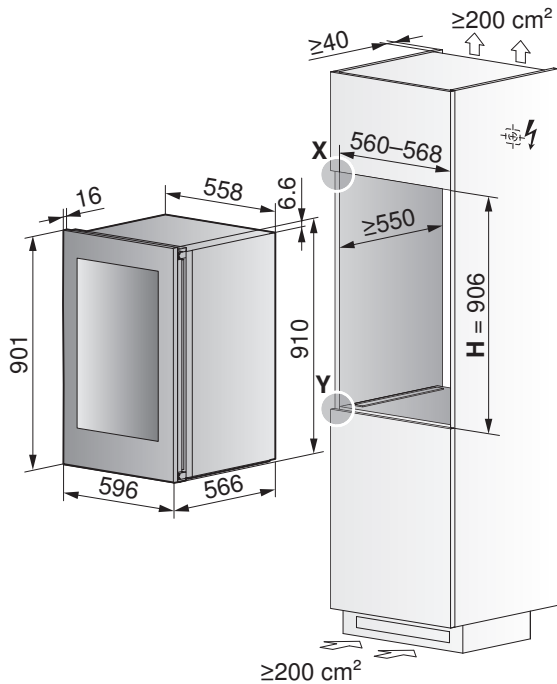

Detail X

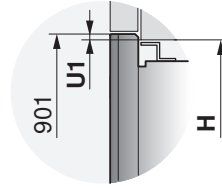

Detail Y

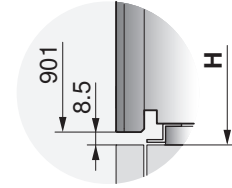

Overview: Possible combinations

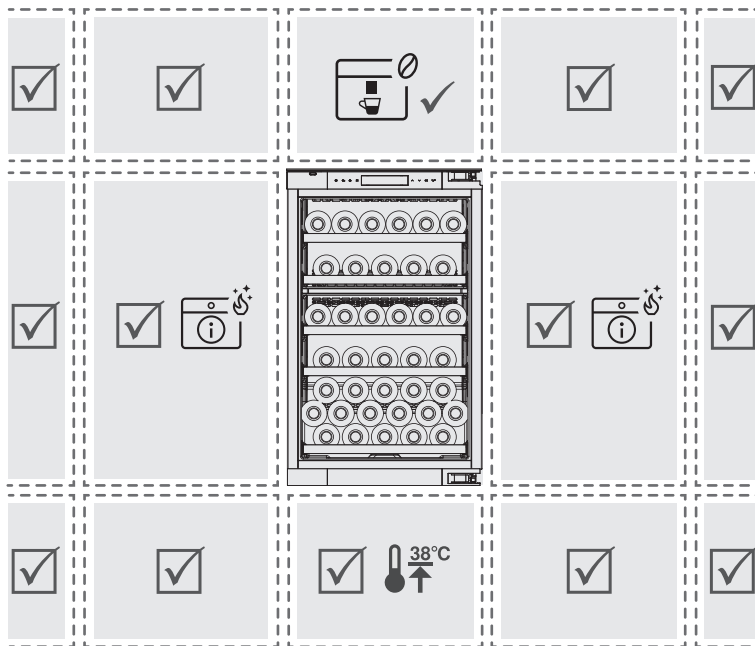

- ✓ Only this type of appliance is allowed
- ✓ All appliances are allowed
- ⓘ An appliance with pyrolytic cleaning function is not recommended!
- ☕ Automatic built-in coffee machine
- 🌡️ 38°C Up to a maximum room temperature of 38 °C.

ⓘ A combination whereby a pyrolytic appliance is positioned to the left or right of the WineCooler is not recommended. In the event of such a combination, the temperature that has been set for the WineCooler cannot be guaranteed during pyrolysis. As a result, the temperature of the stored wine can fluctuate.

Model	Installation type	Niche height H	Overlap U1
51102	EURO 60	906 ^{+2/0}	3.5 mm

WineCooler V4000 45 (51113)

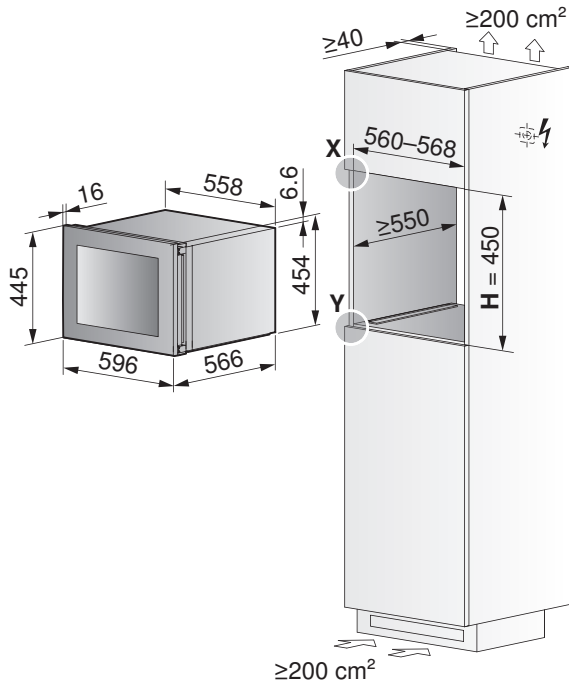

Detail X

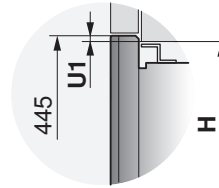

Detail Y

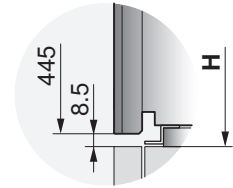

Installing with vacuum drawer or system drawer

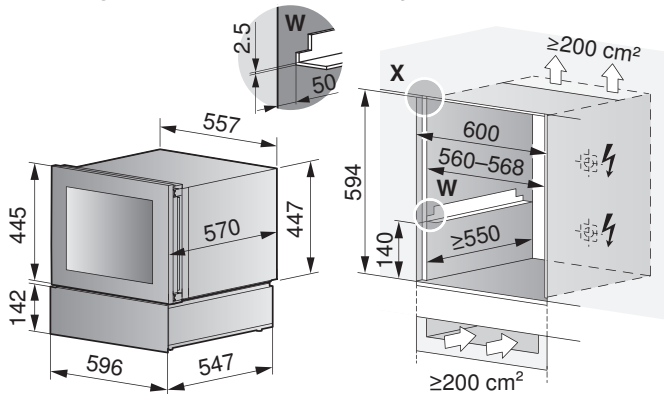

Installing with automatic built-in coffee machine

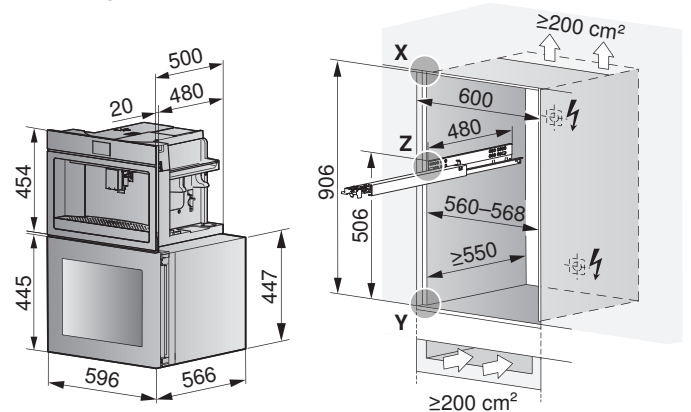

Front dimensions of the appliances: Detail X/Y (see page 11) and Detail Z

Overview: Possible combinations

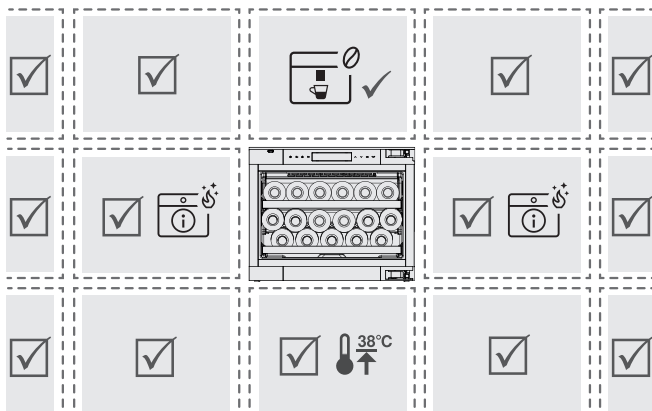

- ✓ Only this type of appliance is allowed
- ✓ All appliances are allowed
- ⚠ An appliance with pyrolytic cleaning function is not recommended!
- ☕ Automatic built-in coffee machine
- 🌡️ Up to a maximum room temperature of 38 °C.

⚠ A combination whereby a pyrolytic appliance is positioned to the left or right of the WineCooler is not recommended. In the event of such a combination, the temperature that has been set for the WineCooler cannot be guaranteed during pyrolysis. As a result, the temperature of the stored wine can fluctuate.

Model	Installation type	Niche height H	Overlap U1
51113	EURO 60	450 ^{+2/0}	3.5 mm

WineCooler V6000 60 Supreme (51154) (integrable)

Gross weight: 153 kg. Maximum permissible weight of door panel: 34 kg.

Electrical connection cable: 2.5 m.

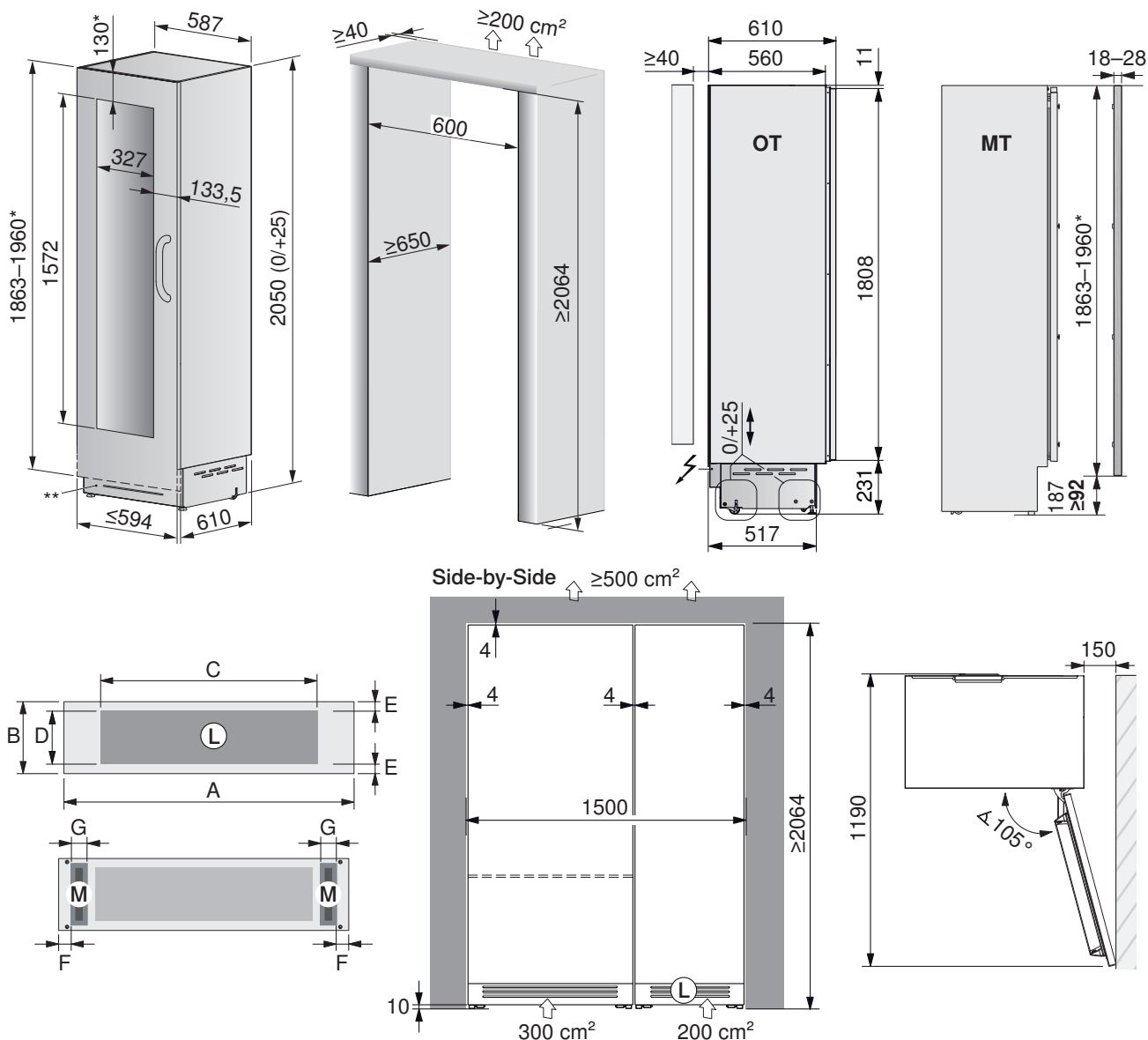

* = For niche height >2064, drill holes in and height of door panel must be adjusted (see installation instructions).

** = Chrome front grille can be replaced by kitchen cabinet front (for dimensions see installation instructions).

OT View without door panel, **MT** View with door panel, **L** Air inlet (at least 50% open), **M** Magnet for mounting.

Dimensions for ventilation grille and position of magnet:

A = 594, **B** = 215, **C** = 400, **D** = 200, **E** = approx. 10, **F** = 60, **G** = 15-30.

Installation accessories: Chrome steel door panel set (incl. pearl door handle) width: 594, height: 1904.

Hinge left: Article no. **1090121**, hinge right: Article no. **1087156**,

For side-by-side installation: Lateral plastic connecting angle, plastic cover strip and intermediate plastic cover strip are included in the scope of delivery.

Model	Installation type	Niche height H
51154	EURO 60	>=2064

15.7 Freezers

Side-by-side installation



Refrigerators **K** and freezers **G** can be installed left/right or vice versa. The appliances must be installed in separate cabinet units.

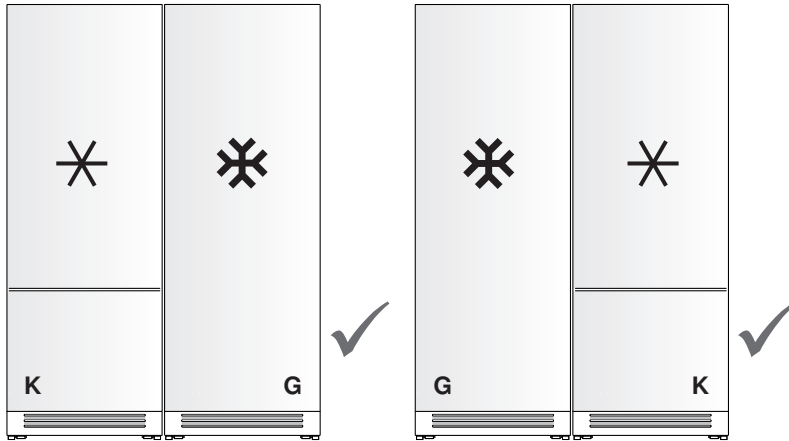

Freezer V4000 178N (53005), (integrable)
 Maximum permissible weight of door panel: 26 kg

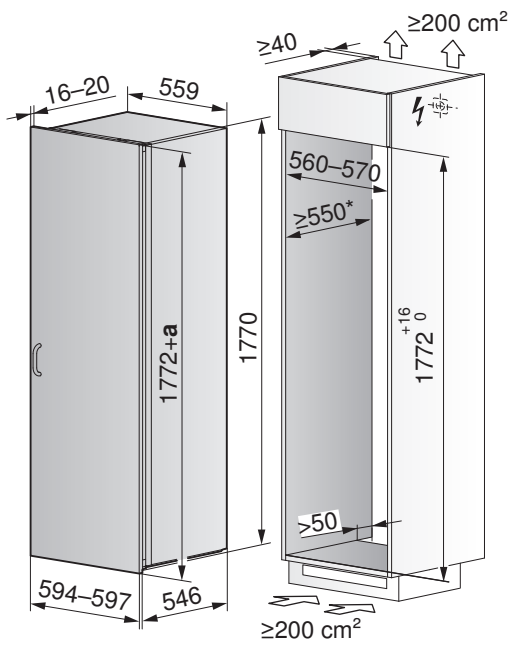

a Overlap, * = Recommendation: 560 mm.

Freezer V6000 60 Supreme (53006)

Gross weight: 153 kg. Maximum permissible weight of door panel: 34 kg. Water connection: Length 2.5 m, complies with EN 61770. Fixed water connection : 3/4" internal thread, inlet pressure from 0.05 MPa to 0.5 MPa (0.5 bar to 5 bar). The water connection must be accessible at all times. Electrical connection cable: 2.5 m.

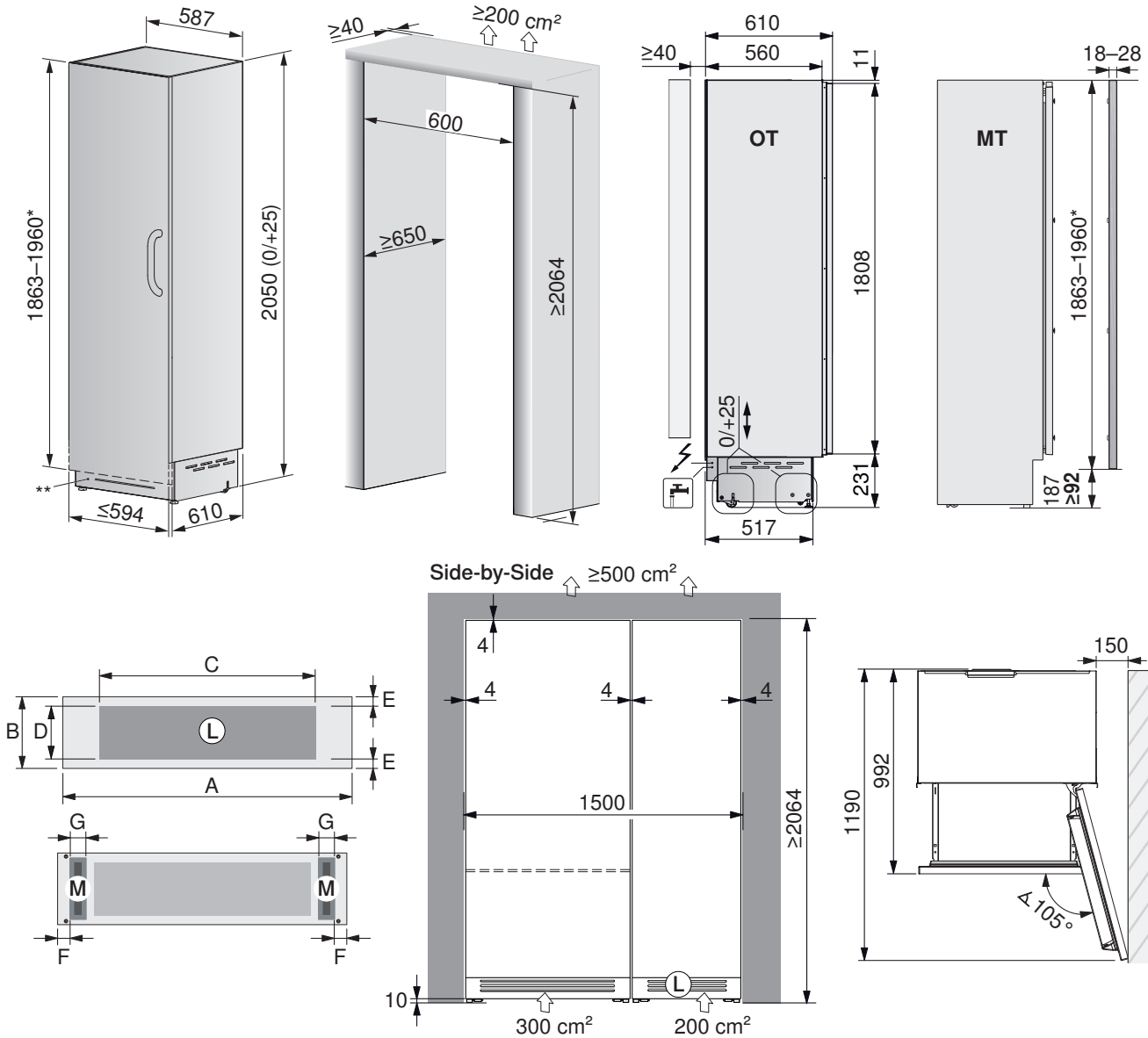

* = For niche height >2064 , the height of door panel must be adjusted.

** = Chrome front grille can be replaced by kitchen cabinet front (for dimensions see installation instructions).

OT View without door panel, **MT** View with door panel, **L** Air inlet (at least 50% open), **M** Magnet for mounting.

Dimensions for ventilation grille and position of magnet:

A = 594, **B** = 215, **C** = 400, **D** = 200, **E** = approx. 10, **F** = 60, **G** = 15-30.

Installation accessories: Chrome steel door panel set (incl. pearl door handle) width: 594, height: 1904.

Hinge left: Article no. **1090126**, hinge right: Article no. **1090125**,

For side-by-side installation: Lateral plastic connecting angle, plastic cover strip and intermediate plastic cover strip are included in the scope of delivery.

16 Accessories

16.1 Ovens / steamers / microwave ovens / coffee machines / vacuum drawers / warming drawers / system drawers

Designer handle for CombiSteamer V6000 45L Grand

Colour	Length	Art. no.
Black	760 mm	1190681
Platinum		1190682
Pearl		1190683

Compensation elements

Ventilation grille

- The ventilation grille for the Advanced Line is used for appliances with a glass ceramic hob installed above them.
- For installation with the appliance, see installation instructions 1241031.

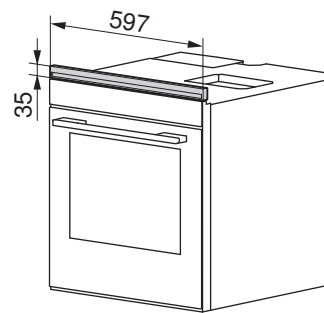

Colour	Material	Art. no.	Type of construction	Compatible with
Nero	Metal	1257770	60-600	Comhair V600
White	Metal	1257771	60-600	
ChromeClass	Metal	1257772	60-600	

Adapter frame

- The adapter frame for the Advanced and the Excellence Line is used beneath the appliance.
- For installation in a niche, see installation instructions J731050.

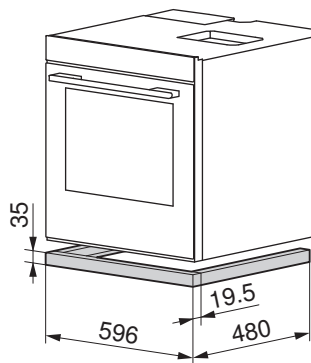

Colour	Material	Art. no.	Type of construction	Compatible with
Nero	Plastic	K38136	60-600	Combair, CombairSteamer, CombiSteamer, Steamer
White	Plastic	K38137	60-600	
Mirror glass	Glass	K38134	60-600	
ChromeClass	Plastic	K48135	60-600	

Angle set for combination possibilities

- For installation, see installation instructions J21021050.
- ▶ In the niche mount to the wood left and right.
- ▶ The appliance is placed on the mounting angles and pushed into the niche.

Art. no. K50572, construction type EURO

S Unit front

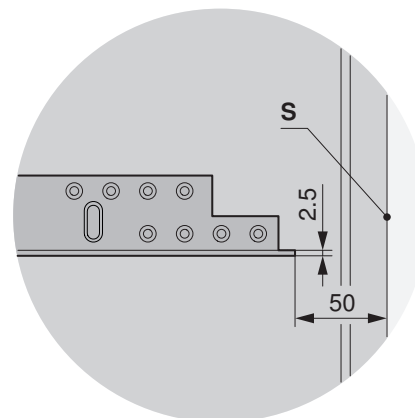

Trim kit (edge protection)

- For installation, see installation instructions: **1044771, 1044772, 1075944.**

Art. no. 1056472 trim kit (edge protection) only needs to be ordered once.

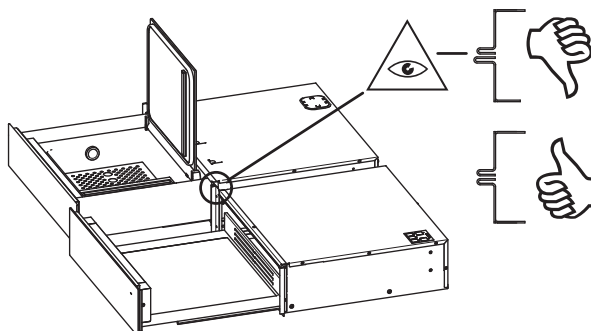

Anti-tip set for VacuDrawer V6000

- For installation, see installation instructions: **1044772**.

Art. no. 1016692 Anti-tip set only needs to be ordered once.

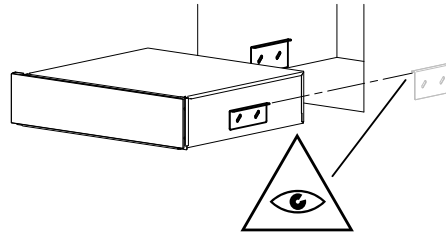

Design cover

The design cover covers the intermediate base for EURO niches and is for a combined installation of two appliances e.g. oven **1** and CombiSteamer **2**. The cover is dimensioned for panel overlapping of 4 mm.

- For installation, see installation instructions J340050.
- Depending on the thickness of the intermediate base **b**, two variants (nero) of the design cover **A** are available:

Art. no. K37158 (**b** = 16 mm / **a** = 10.5 mm)

Art. no. K37159 (**b** = 19 mm / **a** = 13.5 mm)

Aesthetic profile

Assembly kit with aesthetic profile for installing Miwell next to another appliance.

- For installation, see installation instructions 1009019.

Art. no.1009179

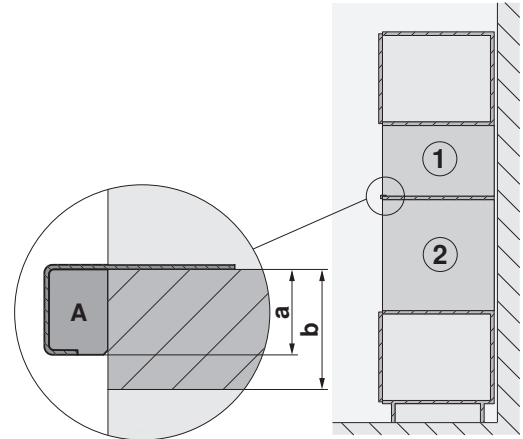

Drain hose

5-m long drain hose for CombiSteamer V6000 45F with fixed water connection.

Art. no.1012933



16.2 Hobs and gas hobs

Ventilation protective plate set for installation below induction hobs		Article no.	Installation instructions
Niche width 600 mm with seal Niche width 825 mm with seal Niche width 900 mm with seal	For all other induction appliances	H61083 H61084 H61085	J40248
Niche width 600 mm without seal Niche width 825 mm without seal Niche width 900 mm without seal	- for induction CookTop V4000 I904 CookTop V4000 I904	H61087 H61088 H61089	
Ventilation grille, height 35 mm for built-under short ovens		Article no.	Installation instructions
Type of construction 60-600			
White Nero ChromeClass ChromeClass (TouchClean)		H63161 H63163 H63165 H63256	J40254
Type of construction 60-450			
Nero ChromeClass ChromeClass (TouchClean)		H60039 H60041 H60053	J40250
Type of construction 60-381			
Nero ChromeClass ChromeClass (TouchClean)		H60033 H60035 H60049	J40252
Angle set for flush installation with straight stone cut		Article no.	Installation instructions
Hob size 30 Hob size 40 Hob size 60 Hob size 70 Hob size 80 Hob size 90 Hob size 90 Panorama		H63770 H63771 H63772 H63773 H63774 H63775 H62568	J004130
Set for flush installation		Article no.	Installation instructions
Sealing strip set		H63283	J004130
Spacer set		H60330	
Adjusting brace set for installation in glass worktops		Article no.	Installation instructions
Adjusting brace set		H62510	J41699
Foam profile (for retrofitting existing ventilation plates)		Article no.	Installation instructions
Length: 520 mm Length: 570 mm Length: 780 mm Length: 870 mm		H63651 H63652 H63653 H63654	-





Intermediate support sets for combined installation	Article no.	Installation instructions
Stainless steel intermediate support for the surface-mounted combination of several hobs	1014361	1013770
Black intermediate support for the surface-mounted combination of several hobs	1019199	
Side strips for combination installation with Teppan Yaki and hob hood	1028587	
Intermediate support (2× contained in set) for the flush-mounted combination of several hobs	H63789	1014378

Special gas hobs	Article no.
Gas deflector for DSMS combination and gas hob	1031218
Sealing ring for gas connection, flat	1030096

Installation accessories for hobs	Article no.
OX Mini Quick, instant adhesive for installation of the steel angle (50 ml)	B11657
Mixing nozzle for Gel Mix, replacement mixing nozzles for instant adhesive (set of 12)	B11656
AKEPOX Gun Gel Mix + Mini Quick for 50 ml cartridges	B75202
Sealing strip set (tape and spacer material)	H63283
Sealing tape 10 × 3 × 2800	86392887
Sealing tape 5 × 1.5 × 2552	H62377
Spacer set	H60330
TREMCLEAN isopropyl alcohol (1000 ml)	1056609
Black silicone FA880 (310 ml)	B11555
Anthracite silicone FA880 (310 ml)	B11556
White silicone FA880 (310 ml)	1031313
Stone grey silicone FA880 (310 ml)	1031314
Marble smoothing agent AA320 (1000 ml)	B11557

Nozzle sets for gas hobs in the overview (see page 53)

Accessories for CombiCookTop V2000 I604 (31175/31176)

Telescopic connection	Extension duct	90° flat channel elbow	Transition piece, straight
			
1314011	1314012	1314013	1314014

16.3 Range hoods



Technical information on the range hoods can be found in document «TechInfo for range hoods» under J32836 (EN), 1007182 (IT), 1008408 (DE), 1008409 (FR).

Protective plate for side walls

The protective plates for the side walls are needed to protect the sides of the wall unit from grease and moisture.

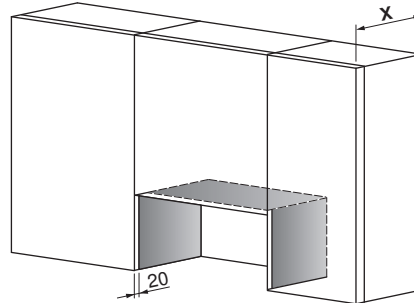

Designation	Dimensions (height x depth)	Wall unit depth x	Colour	Article no.
Protective plate for side walls	235 x 310 mm	330 mm	White	K26092
Protective plate for side walls	235 x 310 mm	330 mm	Nero	K26093
Protective plate for side walls	235 x 310 mm	330 mm	ChromeClass	K26094
Protective plate for side walls	235 x 330 mm	350 mm	White	H42792
Protective plate for side walls	235 x 330 mm	350 mm	Nero	H42791
Protective plate for side walls	235 x 330 mm	350 mm	ChromeClass	H42790
Protective plate for side walls	235 x 350 mm	370 mm	White	H42795
Protective plate for side walls	235 x 350 mm	370 mm	Nero	H42794
Protective plate for side walls	235 x 350 mm	370 mm	ChromeClass	H42793

Fastening elements

Pipe clip with thread

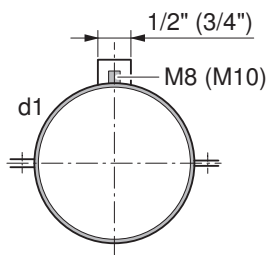

Description

For mounting the helically wound pipe
2-part set with sound insulation insert, incl. screws and nuts
Galvanized steel, thread M8

Art. no.
H42050

d1
ø150 mm

Double-threaded pin M8, galvanized

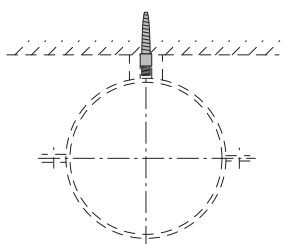

Description

For mounting the pipe clip in the concrete wall
Length 40 mm

Art. no.
H42057

Quick-locking hose clamp

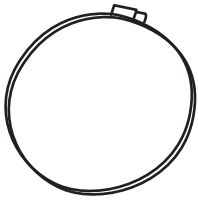

Art. no.

33121304
 33121336

ø110–130 mm
 ø150 mm

Connecting nipples / Connecting pipes

Connecting nipple

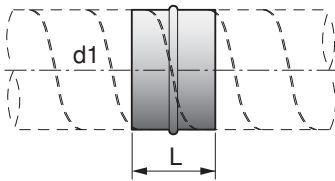

Description

Sendzimir galvanized sheet steel
 L = 80 mm

Art. no.
 H42031

d1
 ø150 mm

Connecting pipe

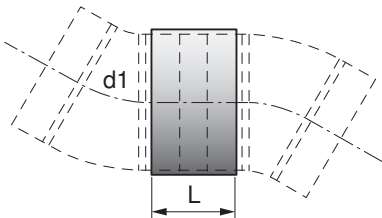

Description

Sendzimir galvanized sheet steel
 L = 90 mm

Art. no.
 H42032
 H42033

d1
 ø125 mm
 ø150 mm

Elbow

Elbow 90°

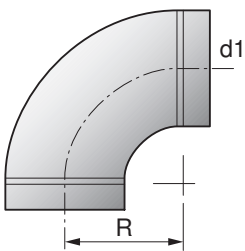

Description

Elbow, pressed, R = d1
 Use with flexible and rigid pipes
 Sendzimir galvanized sheet steel

Art. no.
 H42034
 H42036

d1
 ø125 mm
 ø150 mm

Reducers

Reducer

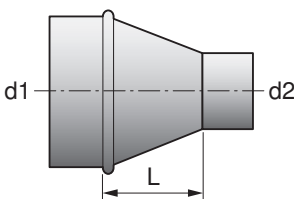

Description

Pressed version, L = 22 mm
 Sendzimir galvanized sheet steel

Art. no.
 H42040

d1
 ø150–125 mm

Pipe end pieces

Pipe end piece

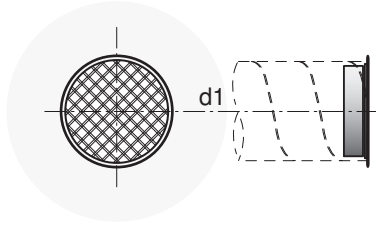

Description

Connection with grille
Sendzimir galvanized sheet steel

Art. no. H42048
d1
ø150 mm

Weather protection grille

Weather protection grille

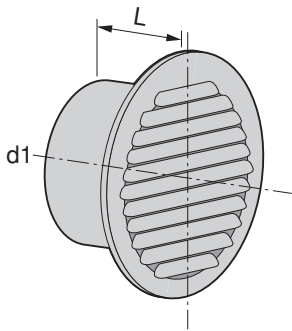

Description

Weather protection grille without a non-return flap valve, round, pressed, made from aluminium. With fly screen and connection piece, L = 45 mm.

Note: This article is not recommended in combination with range hoods.

Art. no. H42064 d1ø150 mm

Recommended articles:

Art. no. 1284718 ø150 mm, L=141 mm
Art. no. 1284716 ø150 mm, L=115 mm

Wall pipes

Telescopic wall pipe with non-return flap valve

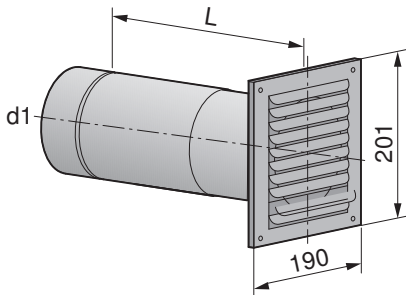

Description

3-part set, L = Wall thickness 300–460 mm
Sendzimir galvanized sheet steel

Grille made from aluminium; can be painted

Art. no. H42065 d1
H42065 ø125 mm
H42066 ø150 mm

Flaps

Non-return flap valve with sealing lip

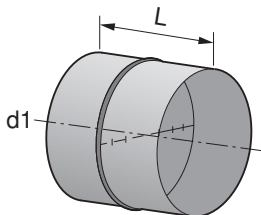

Description

Made from robust sheet steel

For flexible and rigid pipes, L = 80 mm

Art. no. H42061 d1
H42061 ø125 mm
H42062 ø150 mm

Hoses

Aluminium hose, semi-flexible

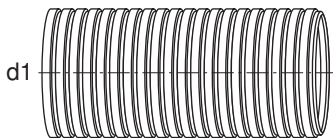

Description

Round Aluflex, semi-flexible
Dimensionally stable, flame resistant
1 à 3 m

Art. no.	d1
H42051	ø125 mm
H42052	ø150 mm
H40168	ø160 mm

Aluminium hose, highly flexible

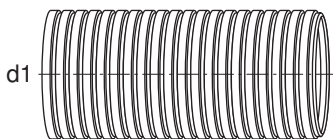

Description

Round Aluflex, highly flexible
Internal bending radius 30–60 mm
Dimensionally stable, flame resistant

Art. no.	d1
H42053	ø125 mm, 1 à 10 m
16955803	ø150 mm, 1 à 15 m

Noise insulation, aluminium

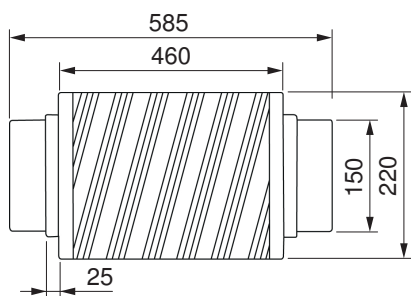

Description

Noise insulation made of aluminium for ø150 mm pipe.
Noise reduction of up to 22 dB.

Art. no.	ø150 mm
1030591	

Fire damper / Shut-off device

Round fire damper

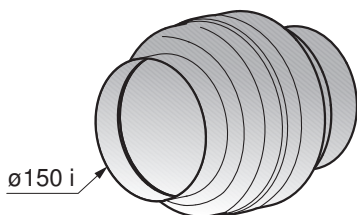

Description

Round fire damper, certified by VKF (Swiss Association of Cantonal Fire Insurance Companies), trigger at 70 °C, connection to plastic pipe possible, can be installed horizontally or vertically

Art. no.	ø150 mm
1157473	

Weather protection grille

Weather protection grille for plastic flat channel

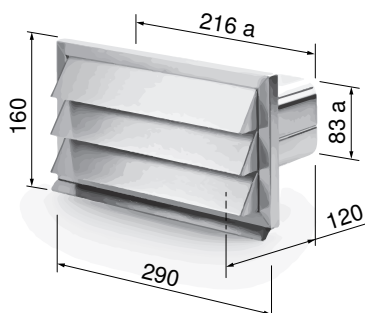

Description

Ventilation grille for plastic flat channel, ChromeClass with non-return flap valve. Compatible with flat channel art. no. 1012780

Art. no.	290 × 160 mm
1030590	

Flat channel systems made of plastic (PRIME)



Accessory parts made of non-fireproof plastic.

Prime flat channel

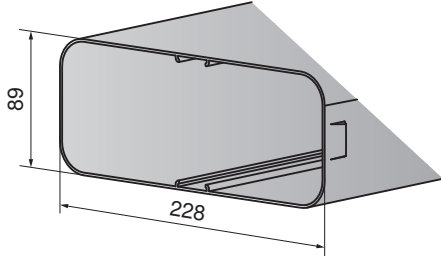

Description

Ventilation pipe

Art. no.

1284699

L=1000 mm

Prime flat channel

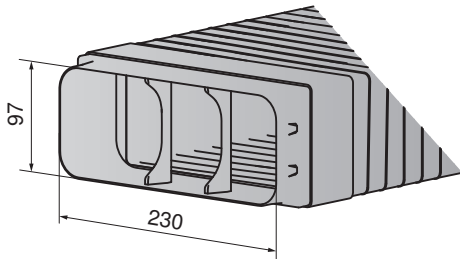

Description

Flexible, deflection and rotation up to 90°

Art. no.

1284706

L=250–550 mm

Prime universal connector for flat channel

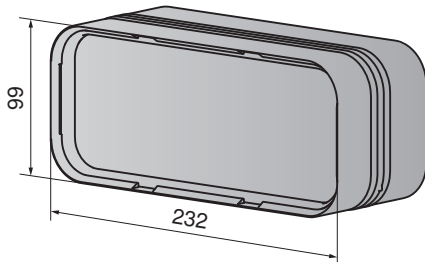

Description

For straight ventilation pipes

Art. no.

1284698

L=85 mm

Prime transition piece

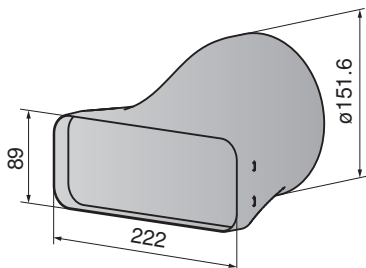

Description

From flat to round, fluidically optimized

Art. no.

1284701

L=166 mm

Prime 90° flat channel elbow

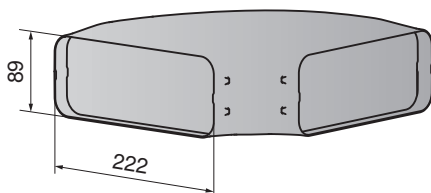

Description

Horizontal to flat channel

Art. no.

1284702

L=289 mm

Prime 90° flat channel elbow

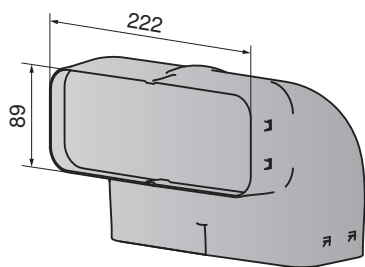

Description

Vertical for 90° flat channel

Art. no.

1284704

W×H=163×163 mm

Prime 90° diverter piece

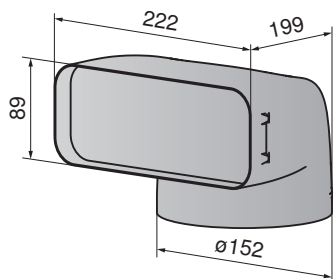

Description

Vertically from flat to round

Art. no.

1284707

L=200 mm

Prime duct spacer for flat channel

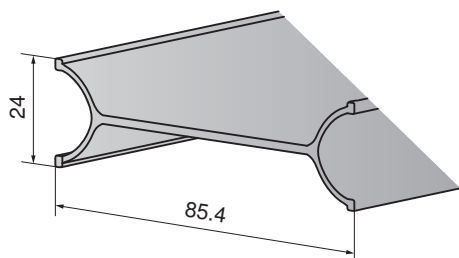

Description

Step load of up to 100 kg

Art. no.

1284700

L=400 mm

Prime 30° flat channel elbow

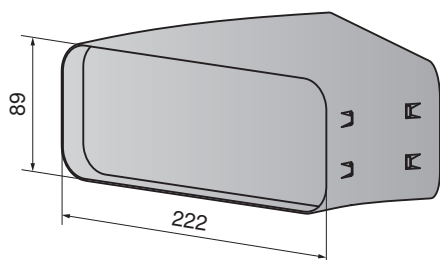

Description

Horizontal for flat channel

Art. no.

1284703

W×H=222×89 mm

Prime 90° flat channel elbow, narrow

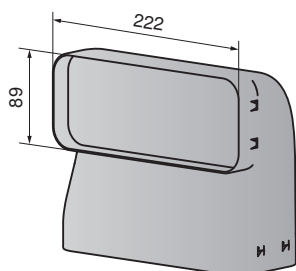

Description

Vertical for flat channel

Art. no.

1284705

W×H=222×89 mm

Prime mounting bracket

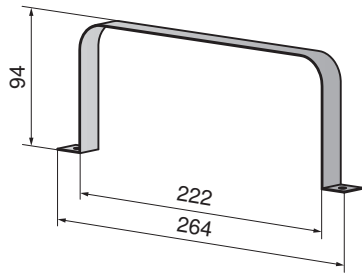

Description

Stainless steel for flat channel

Art. no.

1284708

W×H=222×93 mm

Prime universal connector for round pipes

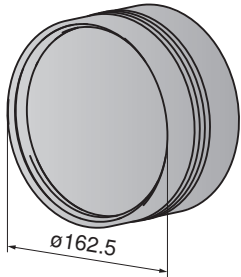

Description

Connection \varnothing 150 mm

Art. no.

1284709

L=85 mm

Prime ventilation grille for base

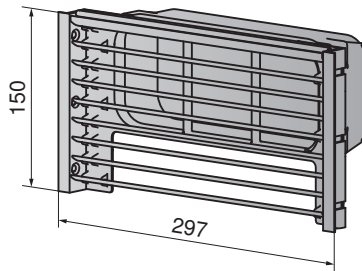

Description

Stainless steel coloured, suitable for plinth height 100–150 mm (can be shortened)

Art. no.

1284717

L=84 mm

Prime round pipe

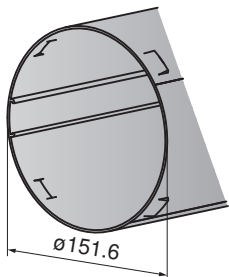

Description

Connection \varnothing 150 mm

Art. no.

1284710

L=1000 mm

Prime 90° pipe elbow

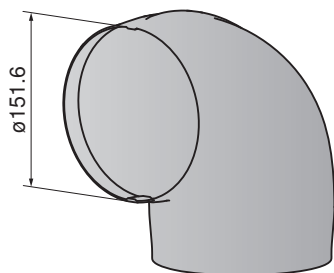

Description

Connection \varnothing 150 mm

Art. no.

1284711

W×H=226×226 mm

Prime round channel bracket

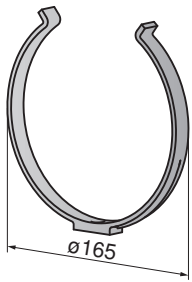

Description

For round pipe, $\varnothing 150$ mm

Art. no.

1284712

L=14 mm

Prime wall box, round

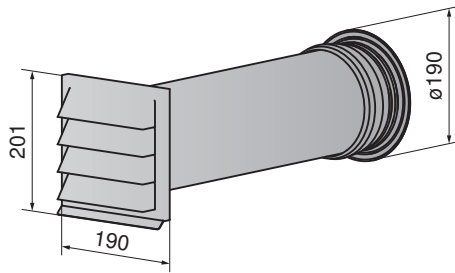

Description

Incl. stainless steel weather protection grille and non-return flap valve, connection $\varnothing 150$ mm

Art. no.

1284713

L=220–550 mm

Prime wall box, from flat to round

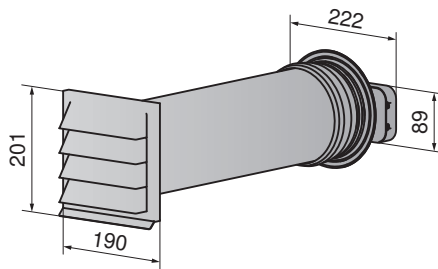

Description

Incl. stainless steel weather protection grille and non-return flap valve, connection $\varnothing 150$ mm

Art. no.

1284714

L=220–550 mm

Prime transition piece, narrow

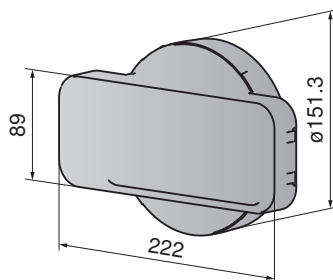

Description

From narrow to round, $\varnothing 150$ mm

Art. no.

1284715

L=60 mm

Prime turbo weather protection grille, round

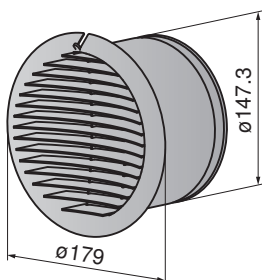

Description

Stainless steel without non-return flap valve, $\varnothing 150$ mm

Art. no.

1284716

L=115 mm

Weather protection grille, round

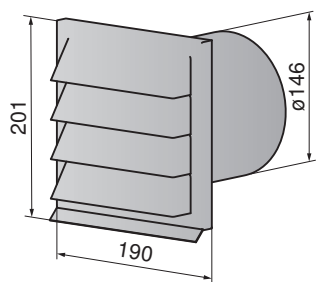

Description

Stainless steel with non-return flap valve, \varnothing 150 mm

Art. no.

1284718

L=141 mm

Weather protection grille, vertical

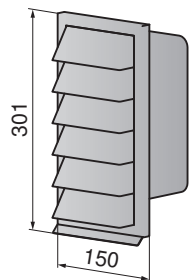

Description

Stainless steel with non-return flap valve, for connection to flat channel

Art. no.

1284719

L=120 mm

Flat channel systems made of metal, fire protection class RF 1



Accessory parts made of fireproof metal

Flat channel

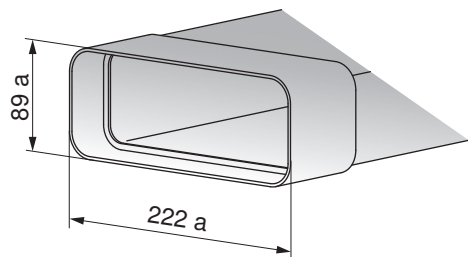

Description

Flat channel with seal

Art. no.

1046627

L = 500 mm

Flat channel

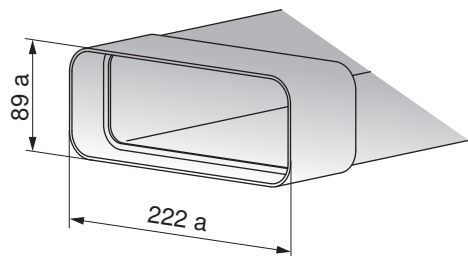

Description

Flat channel with seal

Art. no.

1046628

L = 1000 mm

Reinforcing rib for embedding in concrete

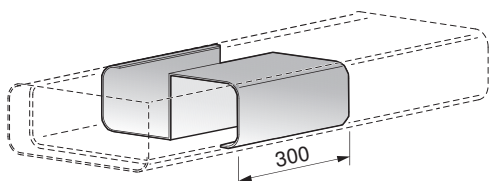

Description

Reinforcing rib for embedding in concrete (tread load of up to 100 kg)

1× required for use in flat channel (L = 500 mm) art. no. 1046627

2× required for use in flat channel(L = 1000 mm) art. no. 1046628

Art. no.

1077495

L = 300 mm

Flat channel, flexible

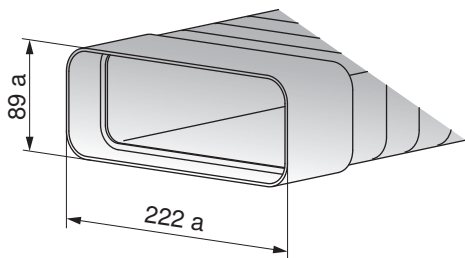

Description

Flat channel, flexible, with seal

Art. no.

1046629

L = 500 mm

Flat channel, flexible

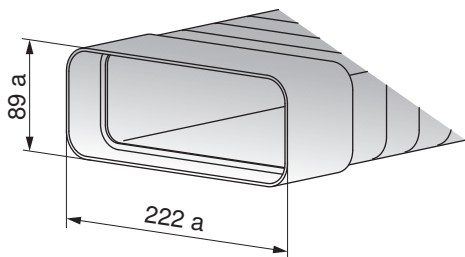

Description

Flat channel, flexible, with seal

Art. no.

1046635

L = 1000 mm

Channel connector

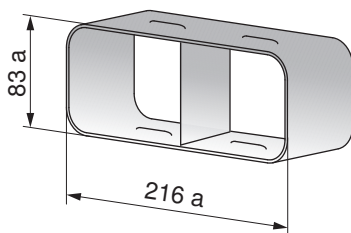

Description

For straight flat channels

Art. no.

1046636

L = 100 mm

Diverter piece on flat channel 90°

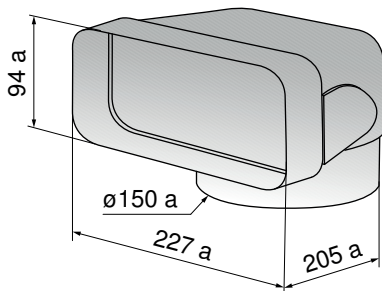

Description

For direct hood connection with air guides and formed sleeve at one end

Art. no.

1046638

Flat elbow connector

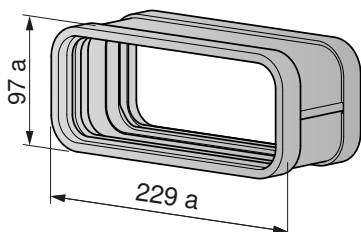

Description

For connecting two flat channel elbows, with two pre-assembled profiled seals.
 (Not suitable for connecting flat channel pipes.)

Art. no.

1188102

Length = 90 mm

Elbow 90°, horizontal

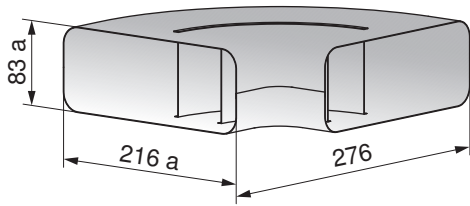

Description

Elbow with air guides

Art. no.

1046639

Elbow 90°, vertical

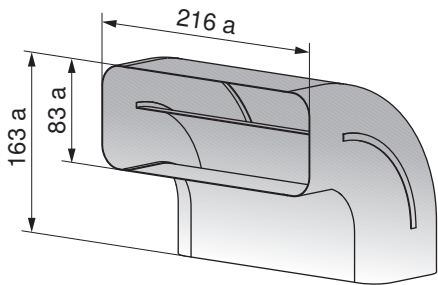

Description

Elbow with air guides

Art. no.

1046643

Transition piece for flat channel

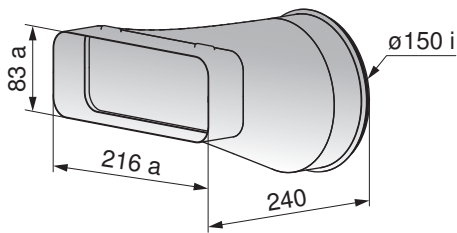

Description

For direct transition from flat to round, fluidically optimized

Art. no.

1046644

Pipe connection

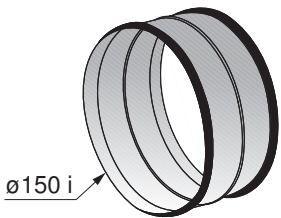

Art. no.

1046646

d = 150 mm

Offsetting end piece on base motor

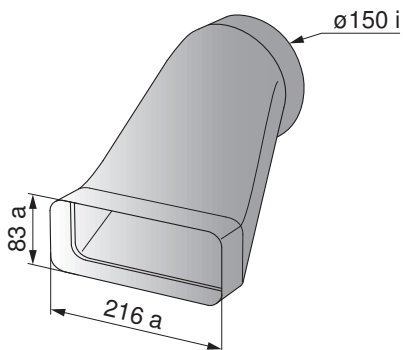

Art. no.

1046649

Pipe set for hob hoods

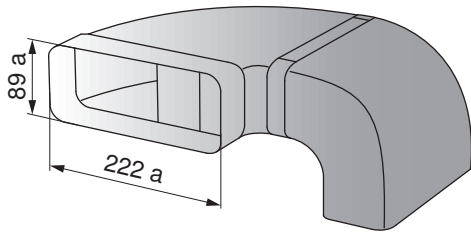

Art. no.
 1046650

Flat channels, standard metal

Flat channel

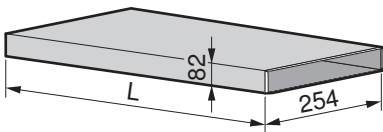

Description

Exhaust ducting system with very low installation height of 82 mm
 Sendzimir galvanized sheet steel
 Corresponds to nominal diameter \varnothing 150 mm

Art. no.

H42068 L = 1000 mm
 H42069 L = 600 mm

Reinforced flat channel

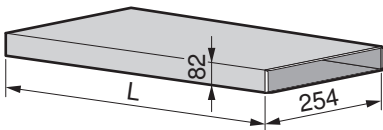

Description

Exhaust ducting system with very low installation height of 82 mm
 Sendzimir galvanized sheet steel
 With reinforcement for concreting in
 Corresponds to nominal diameter \varnothing 150 mm

Art. no.

H42085 L = 600 mm
 H42086 L = 1000 mm

Telescopic flat channel

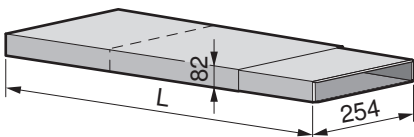

Description

Exhaust ducting system with very low installation height of 82 mm
 Sendzimir galvanized sheet steel
 Corresponds to nominal diameter \varnothing 150 mm

Art. no.

H42070 L = 275–535 mm

Reinforcing rib for flat channel

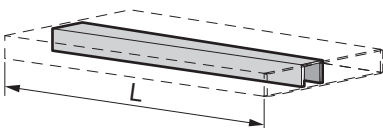

Description

For concreting in flat channel

Art. no.

H42071 L = 600 mm
 H42072 L = 1000 mm

Mounting bracket for flat channel

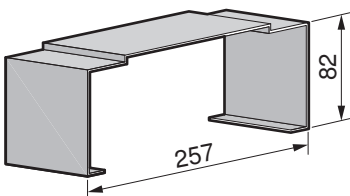

Art. no.

H42073

Elbow 90°, vertical, for flat channel

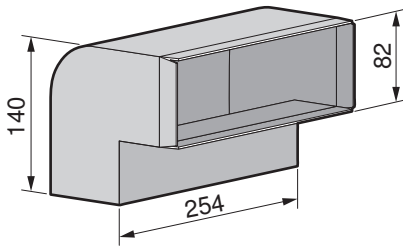

Art. no.
 H42074

Elbow 45°, vertical, for flat channel

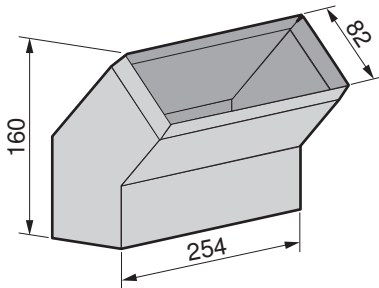

Art. no.
 H42075

Elbow 90°, horizontal, for flat channel

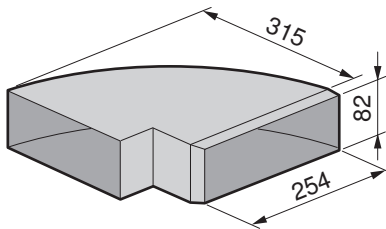

Art. no.
 H42076

Elbow 45°, horizontal, for flat channel

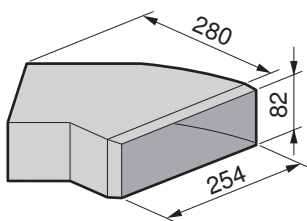

Art. no.
 H42077

Transition piece for flat channel

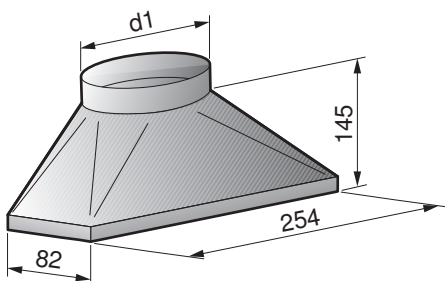

Description

For transition from round to flat

Art. no.
 H42078

d1
 ø150 mm

Diverter piece on flat channel

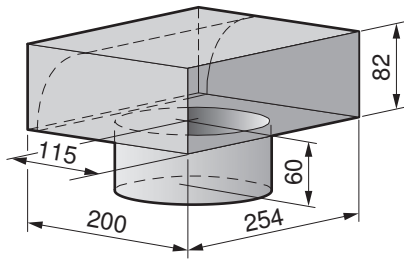

Art. no.
 H42087
 H42079

Connection \varnothing 125 mm
 Connection \varnothing 150 mm

Flat channel wall box

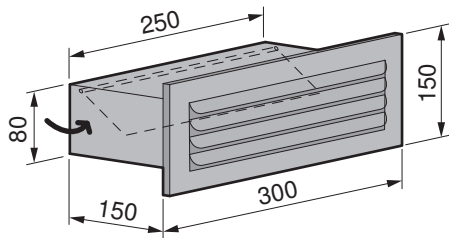

Description

With non-return flap valve and weather protection grille

Art. no.
 H42054

Sealing tape

Aluminium tape

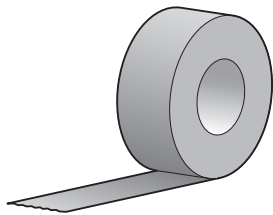

Description

Fabric-reinforced tape, with protective film, 50 mm x 50 m roll

Art. no.
 H42067

16.4 Dishwashers

AdoraDish

Designation	Article no.
Set of reinforced springs for heavy decor front panels – grade 2 yellow	1206327
Set of reinforced springs for heavy decor front panels – grade 3 green	1206328
Set of reinforced springs for heavy decor front panels – grade 4 red	1206329

Diverse sets

Designation	Article no.	Remarks
Slide plate set 60 cm, special niche 1.5 mm	W84789	For extra-height appliances with a width of 60 cm. In place of the plinth runners for the installation on a plinth or in a tall unit.
Compensator set, black	W82043	Additional order for «mirror glass» appliances. The set can also be used for «ChromeClass» appliances.
Plinth runner	W82930	For height compensation in a niche
Work surface protection	W70163	Protection against escaping moisture
CS set of long hoses V6000 / V4000B	1032108	Conversion to 3 m Aquastop and 3 m drain hose*
CS set of long hoses V2000 / V4000	1091481	Conversion to 3 m Aquastop and 3 m drain hose*
CS set containing door hinge brake	1011228	For very heavy decor panels for appliances with door opener



* Conversion must be carried out by qualified personnel.

16.5 Refrigerating and freezing appliances

Designation	Article no.	Remarks
Supplementary kit Euro 60 (with filler strip). For all CombiCoolers, except for the V6000 Supreme.	1066699	Length 1780 mm
Adapter profile WineCooler V4000 8U (51158)	1062627	Height ≥ 30 mm
Fixing plate for handleless fronts , for use with all CombiCoolers, except for the V6000 Supreme.	H73409	-
Assembly set made of metal for fastening decorative door panel , for use with all CombiCoolers, except for the V6000 Supreme.	1171133	For heavy fronts, the metal assembly set can be ordered in place of the plastic angle bracket supplied.

Installation accessories for		
CombiCooler V6000 90 Supreme		
Chrome steel door panel set, hinge right	1087155	Width 894 mm, height of refrigerating section 1320 mm, height of freezer section 581 mm, thickness 20 mm
Chrome steel door panel set, hinge left	1090119	
Black door handle, 760 mm	1234973	Door handle for freezer section (horizontal). Distance between threaded holes 585 mm, height 48 mm. For fastening, use M5 screws of a length appropriate for the door panel thickness.
Platinum door handle, 760 mm	1234974	
Pearl door handle, 760 mm. This door handle is included in chrome steel door panel set 1087155 and 1090119.	1234975	
CombiCooler V6000 75 Supreme		
Chrome steel door panel set, hinge right	1281228	Width 744 mm, height of refrigerating section 1320 mm, height of freezer section 580 mm, thickness 18 mm
Chrome steel door panel set, hinge left	1281229	
Black door handle, 625 mm	1313270	Door handle for freezer section (horizontal). Distance between threaded holes 520/585 mm, height 48 mm. For fastening, use M5 screws of a length appropriate for the door panel thickness.
Platinum door handle, 625 mm	1313272	
Pearl door handle, 625 mm. This door handle is included in chrome steel door panel set 1281228 and 1281229.	1313271	
Cooler V6000 90 Supreme		
Chrome steel door panel set, hinge right	1087157	Width 894 mm, height 1904 mm, thickness 20 mm
Chrome steel door panel set, hinge left	1090120	
Cooler V6000 75 Supreme		
Chrome steel door panel set, hinge right	1281230	Width 744 mm, height 1904 mm, thickness 18 mm
Chrome steel door panel set, hinge left	1281231	



Installation accessories for		
WineCooler V6000 60 Supreme		
Chrome steel door panel set, hinge right	1087156	Width 594 mm, height 1904 mm, thickness 20 mm
Chrome steel door panel set, hinge left	1090121	
Freezer V6000 60 Supreme		
Chrome steel door panel set, hinge right	1090125	Width 594 mm, height 1904 mm, thickness 20 mm
Chrome steel door panel set, hinge left	1090126	
All V6000 Supreme appliances		
Black door handle, 1060 mm	1249038	Door handle for main refrigerating section (vertical) Distance between threaded holes 840 mm, height 48 mm. For fastening, use M5 screws of a length appropriate for the door panel thickness.
Platinum door handle, 1060 mm	1249040	
Pearl door handle, 1060 mm. Pearl door handle, 1060 mm. This door handle is included in all chrome steel door panel sets.	1249039	
Intermediate plastic cover strip for side-by-side installation	1101167	-
Door opening, stopper 90°	1272005	-
Filler strip to bridge the gap between the appliance door and decor front panel	1275559	-

17 V-ZUG-Home

17.1 Internet access



Internet access is required for use of V-ZUG-Home.

17.2 Scope of delivery

For appliances with V-ZUG-Home, the V-ZUG-Home module is integrated in the appliance and ready for operation. Models with a V-ZUG-Home module can be connected to the home network via WLAN/Wi-Fi.

Type of appliance	Model designation	Model number
Ovens	Combair V600 60 Combair V2000 45/60, Combair V4000 45/45P/60/60P, Combair V6000 45/45P/60/60P	21043, 21045, 21047–21050, 21055, 21057–21059, 21067, 21068, 21070, 21073, 21128
Steamers	Steamer V4000 38/45, CombiSteamer V4000 45, CombiSteamer V6000 45/45F/45L Grand/45M PowerSteam, CombairSteamer V2000 60, CombairSteamer V6000 60	23025, 23026, 23031–23034, 23036, 23038, 23041, 23043, 23045–23047, 23049
Microwaves	CombiMiwell V4000 45	24025
Dishwashers	AdoraDish V2000, AdoraDish V6000	41163, 41147, 41171, 41173
Induction hobs	CookTop V6000 I705 FullFlex, CookTop V6000 I906 FullFlex	31132, 31134
Refrigerators	CombiCooler V4000 178NI, CombiCooler V6000 178NI	51151, 51149
Winecoolers	WineCooler V4000 90/45	51102, 51113

17.3 Connecting to the home network

WLAN/Wi-Fi connection



Establishing a connection between an appliance and a wireless network is described in the operating instructions for «V-ZUG-Home». These can be found at vzug.com.



Index

A

Accessories	125
Compensation elements for combination possibilities	126
Design cover	127
Drain hose	127
for range hoods	130
for refrigerators	145
Gas hobs	129
Adapter frame	126
Adjusting brace set	128
Angle set	128
Angle set for combination possibilities	126

B

Built-in range hoods	93
----------------------------	----

C

Coffee machines	
Accessories	125
Compensation elements	
Adapter frame	126
Angle set for combination possibilities	126
Design cover	127
Ventilation grille	125
Cookers	18

D

Design cover	127
Dishwashers	
Plumbing-in data	97
Dishwashers with heat pump	106
Electrical connection data	108
Plumbing-in data	108

E

Electrical connection data	
Dishwashers Adora	96
Induction hobs	64
Mini ovens	18
Steamers	13
Warming and system drawers	20
Electrical connections	
Fault currents	5
General operating conditions	5
Microwaves	27
Position	9
Residual current devices (RCD)	5
Electrical connections and installation dimensions	5

F

Fault currents	5
Fire damper / Shut-off device	133
Flat channel systems made of metal	75, 138
Flat channel systems made of plastic	73, 74, 134
Frequency stability	5
Frequency variation	5

G

Gas hobs	
Electrical connection data	51
General operating conditions	5
Glass ceramic hobs	
Examples for combined installation	60
Induction hobs	32

I

Induction hob	32
Induction hobs	
Electrical connection data	32
Installation dimensions	5
EURO	10
Front dimensions	11
Installing	
EURO	10
Intermediate support set	129

M

Microwaves	27
Accessories	125
Mini ovens	
Electrical connection data	18

O

Operating altitude for refrigerating appliances	113
Operating conditions	
General	5
Ovens	18
Accessories	125

P

Plumbing-in data	
Dishwashers Adora	96
Positions of electrical connections	9

R

Range hoods	78
Built-in range hoods	93
Connecting nipples	131
Connecting pipes	131
Elbow	131
Fastening elements	130
Flaps	132
Flat channels	141
Hoses	133
Pipe end pieces	132
Reducers	131
Sealing tape	143
Special hoods	79
TechInfo for range hoods	130
Wall pipes	132
Weather protection grille	132
Refrigerating and freezing appliances	112
Residual current devices (RCD)	5

S

Sealing strip set	128
Spacer set	128
Special hoods	79
Steamers	13
Accessories	125
Electrical connection data	13
Plumbing in	17
Supplementary documents	2
TechInfo for range hoods	130
Symbols used	2
System drawers	20
Accessories	125

T

TechInfo for range hoods	130
--------------------------------	-----



U

Use at altitude..... 5
Useful links 2

V

Vacuum drawer 20
Vacuum drawers
Accessories 125
Validity 6
Ventilation grille 125, 128
Ventilation protective plate set..... 128

W

Warming and system drawers
Electrical connection data..... 20
Warming drawers 20
Accessories 125
Weather protection grille..... 133
Wincoolers..... 120



18 Notes



CONTACT POINT IN AUSTRALIA

Services & Support Australia:

Tel. +61 1300 898 428

service.au@vzug.com

CONTACT IN SWITZERLAND

V-ZUG Ltd

Industriestrasse 66
6302 Zug/Switzerland
www.vzug.com

Service & Support International

service-support@vzug.com

